

User Guide

EVOLIS PREMIUM SUITE

FOR END-USERS

For more information, please visit www.evolis.com

Table of Contents

| | |
|--|----|
| 1. Introduction | |
| 2. General Information | |
| 2.1 Copyright and Trademark | 8 |
| 2.2 Microsoft® Certification | 8 |
| 3. How To Use This Guide | |
| 3.1 Informative Icons | 9 |
| 3.2 Glossary | 9 |
| 4. Overview of the EPS System | |
| 4.1 Possible Configurations | 13 |
| 5. Environment For The Suite | |
| 5.1 Minimum Requirements | 15 |
| 5.2 Languages Available | 15 |
| 5.3 Meeting On Screen Colors and Card Colors | 15 |
| 5.3.1 Installing Evolis Color Profile on WINDOWS® | 16 |
| 5.3.2 Changing Printing Settings | 19 |
| 6. Installation of Evolis Premium Suite | |
| 6.1 Checking Your Current Driver Version | 20 |
| 6.2 Finding the Driver Setup File | 20 |
| 6.3 Running the Installation Wizard | 21 |
| 6.4 Troubleshooting When Installing EPS | 23 |
| 6.5 Three Modes | 24 |
| 6.5.1 Standard Mode | 25 |
| 6.5.2 Supervision Mode | 25 |
| 6.5.3 Minimal Mode | 26 |
| 6.5.3.1 Installation and Access to Printing Settings | 27 |
| 6.6 Configuration of the Connection | 28 |
| 6.6.1 USB Connection | 28 |
| 6.6.2 LAN Connection | 28 |
| 6.6.2.1 Checklist Before Starting | 29 |
| 6.6.2.2 Setting a Fixed IP Address on the Printer | 30 |
| 6.6.2.2.1 Collecting the Required Information | 30 |
| 6.6.2.2.2 Configuring your Printer IP Address | 30 |
| 6.6.2.2.3 Finishing the Detection of the Printer | 31 |

Table of Contents

| | | |
|-------------|---|-----------|
| 6.6.2.3 | Setting a DHCP Address on the Printer | 34 |
| 6.6.2.3.1 | Configuring DHCP address | 34 |
| 6.6.2.3.2 | Detecting the Printer through the Wizard | 37 |
| 6.6.2.4 | Using a Switch | 40 |
| 6.6.2.5 | Checking Connection With the Printer | 41 |
| 6.6.2.5.1 | Maintenance Menu of Printer Properties | 41 |
| 6.6.2.5.2 | Web Interface of the Printer | 41 |
| 6.6.2.5.3 | Ping Command | 41 |
| 6.6.3 | Wi-Fi Connection (Primacy printer only) | 42 |
| 6.6.3.1 | Choosing and Checking the Type of Connection | 42 |
| 6.6.3.2 | Checking the Availability of Wi-Fi Option in the Printer | 42 |
| 6.6.3.3 | Performing the Detection of the Printer in Wi-Fi | 44 |
| 6.6.3.3.1 | Using the Wizard for All Steps | 44 |
| 6.6.3.3.2 | Using the Web Interface and the Wizard | 53 |
| 6.7 | Upating both the EPS and Printer Firmware | 54 |
| 6.8 | Uninstalling the EPS | 57 |
| 7. | Accessing and Changing Printing Settings | |
| 7.1 | Native Driver Printing Settings (all installation modes) | 58 |
| 7.1.1 | Accessing Native Driver Printing Settings | 58 |
| 7.1.2 | Changing Print Settings Through Native Driver: Use Cases | 60 |
| 7.2 | Evolis Printer Properties (all installation modes) | 62 |
| 7.3 | Using the Print Center (Standard and Supervision Modes) | 62 |
| 7.3.1 | Description of Print Center Interface | 63 |
| 7.3.2 | Printer Manager | 64 |
| 7.3.3 | Main Menu | 66 |
| 7.3.3.1 | Settings | 66 |
| 7.3.3.2 | Tools | 66 |
| 7.3.3.2.1 | LCDUpdates | 67 |
| 7.3.3.2.2 | Flip-Over Activation Wizard | 68 |
| 7.3.3.3 | About | 70 |
| 7.3.4 | Printer/Lamination Module Properties | 71 |
| 7.3.4.1 | Printing | 71 |
| 7.3.4.1.1 | Card Orientation | 71 |
| 7.3.4.1.2 | Feeder/Hopper | 73 |
| 7.3.4.1.2.1 | Card Insertion | 73 |
| 7.3.4.1.2.2 | Card Exit | 74 |

Table of Contents

| | | |
|-------------|---|------------|
| 7.3.4.1.2.3 | Card Ejection | 75 |
| 7.3.4.1.2.4 | Card Pre-Loading | 75 |
| 7.3.4.1.3 | Ribbon | 77 |
| 7.3.4.1.3.1 | Ribbon Details | 77 |
| 7.3.4.1.3.2 | Ribbon Manual Settings | 78 |
| 7.3.4.1.3.3 | Front Side and Back Side Settings | 81 |
| 7.3.4.1.3.4 | Printing Resolution | 85 |
| 7.3.4.1.4 | Front Side/Back Side Graphical Settings | 86 |
| 7.3.4.1.4.1 | Brightness and Contrast | 87 |
| 7.3.4.1.4.2 | Black Panel Adjustment | 87 |
| 7.3.4.1.5 | Front Side Varnish Adjustment | 90 |
| 7.3.4.1.6 | Back Side Varnish Adjustment | 93 |
| 7.3.4.1.7 | Front Side/Back Side Text Area | 93 |
| 7.3.4.1.7.1 | Changing the Background RGB levels | 95 |
| 7.3.4.1.7.2 | Printing Black Text: Use of Different Softwares | 96 |
| 7.3.4.1.8 | Advanced Color Parameters | 99 |
| 7.3.4.1.8.1 | Smoothing | 99 |
| 7.3.4.1.8.2 | Short Panel Management | 102 |
| 7.3.4.1.8.3 | Color Adjustment | 103 |
| 7.3.4.1.9 | Advanced Parameters | 104 |
| 7.3.4.2 | Lamination | 104 |
| 7.3.4.2.1 | Printer-Connected Mode | 105 |
| 7.3.4.2.2 | Standalone Mode | 106 |
| 7.3.4.2.3 | Types Of Lamination Films | 106 |
| 7.3.4.2.4 | Lamination Settings | 108 |
| 7.3.4.2.5 | Lamination Device Details | 113 |
| 7.3.4.2.6 | Lamination Maintenance | 114 |
| 7.3.4.2.6.1 | Checking the Status of the Sensors Adjustment through Commands | 114 |
| 7.3.4.2.6.2 | Updating the Lamination Firmware | 115 |
| 7.3.4.2.6.1 | In Printer-Connected Mode | 116 |
| 7.3.4.2.6.2 | In Standalone Mode | 117 |
| 7.3.4.2.6.3 | Performing the Cleaning Task for Lamination | 117 |
| 7.3.4.2.7 | Lamination Tools | 120 |
| 7.3.4.2.8 | Standby Mode and Sleep Mode | 122 |
| 7.3.4.3 | Encoding | 122 |
| 7.3.4.3.1 | Checking the Installation of the Encoding Modules | 123 |

Table of Contents

| | | |
|-------------|--|-----|
| 7.3.4.3.2 | Magnetic Encoding | 125 |
| 7.3.4.3.2.1 | Checking the Installation of the Magnetic Encoder | 125 |
| 7.3.4.3.2.2 | Setting the Encoding Properties | 126 |
| 7.3.4.3.2.1 | Track Settings | 126 |
| 7.3.4.3.2.2 | Coercivity | 128 |
| 7.3.4.3.2.3 | Encoding Through an Application | 128 |
| 7.3.4.3.2.3 | Encoding Through the Print Center | 128 |
| 7.3.4.3.2.4 | Encoding Using Word | 130 |
| 7.3.4.3.2.5 | Encoding Using Cardpresso | 131 |
| 7.3.4.3.3 | Contact/Contactless Encoding | 133 |
| 7.3.4.3.3.1 | Assigning the Adequate Driver for Your Encoder | 134 |
| 7.3.4.3.3.2 | Checking the Installation of the PC/SC Encoder | 136 |
| 7.3.4.3.3.3 | Contact/Contactless Using Cardpresso | 136 |
| 7.3.4.4 | Developing Your In-House Encoding Application | 137 |
| 7.3.4.5 | Cleaning | 137 |
| 7.3.4.5.1 | Cleaning Details | 137 |
| 7.3.4.5.2 | Proceed With Cleaning | 138 |
| 7.3.4.5.2.1 | Proceed With Regular Cleaning | 138 |
| 7.3.4.5.2.2 | Proceed With Advanced Cleaning | 140 |
| 7.3.4.6 | System Details | 142 |
| 7.3.4.6.1 | Testing Cards | 144 |
| 7.3.4.7 | Maintenance | 144 |
| 7.3.4.7.1 | Printer Commands Prompting | 144 |
| 7.3.4.7.2 | Magnetic Encoding Prompting | 145 |
| 7.3.4.7.3 | Printer Driver Settings | 146 |
| 7.3.4.7.4 | Print Head Replacement | 147 |
| 7.3.4.7.5 | Firmware Update | 148 |
| 7.3.4.8 | Administration | 150 |
| 7.3.4.8.1 | Standby Settings | 150 |
| 7.3.4.8.2 | Network Settings (Web Interface) | 152 |

8. Troubleshooting

| | | |
|-------|--|-----|
| 8.1 | Connection Issues | 153 |
| 8.2 | Printing Issues | 154 |
| 8.2.1 | Faded Colors | 154 |
| 8.2.2 | Torn Ribbon | 155 |
| 8.2.3 | Card Design Software with Interfering Options | 156 |

Table of Contents

- 8.2.4 **Unreadable Barcode 159**
- 8.3 Regular Cleaning 160**
- 8.4 Print Head Replacement 160**
- 8.5 Lamination Troubleshooting 161**

1. Introduction

Evolis Premium Suite is more than a driver: it includes many software components that are useful to manage printing jobs.

This guide is intended for end-users with the following objectives:

- installing the Evolis Premium Suite (EPS) in accordance with their working environment, printer(s) and printing goals,
- using the printing settings and tools to configure their printing system,
- managing card customization in an easy and user-friendly way,
- monitoring printing jobs,
- troubleshooting issues potentially met during and after the installation of the EPS,
- viewing most frequent use cases.

The version of Evolis Premium Suite documented in the current User Guide is the driver setup version **6.32.3. 1481**.

The file is available on Evolis website: www.evolis.com/drivers-support

Evolis printers that are managed by the EPS are the following:

- Primacy
- Primacy lamination
- Lamination Module
- Zenius
- Elypso
- KC200/200B
- KM500B/KM2000B

2. General Information

2.1 Copyright and Trademark

© Evolis. All rights reserved.

Users must observe the copyright regulations applicable in their country. This manual must not be photocopied, translated, reproduced, or transmitted, in whole or in part, for any reason and by any electronic or mechanical means whatsoever without the express written consent of Evolis.

All the information contained in this document is subject to change without prior notice.

Evolis cannot be held liable for any loss or damage arising accidentally or as a result of dissemination or use of this manual.

Evolis Premium Suite® and Evolis High Trust® are trademarks of Evolis. All other trademarks belong to their respective holders.

2.2 Microsoft® Certification

Driver setup version 6.32.3. 1481 is certified by Microsoft®:







| | |
|----------------------|--|
| Private product ID: | 13573378536767465 |
| Shared product ID: | 400266485 |
| Submission ID: | 1152921505691474861 |
| Submission date: | 10/09/2020 |
| Completion date: | 10/09/2020 |
| Company: | Evolis |
| Product name: | Evolis Driver |
| Category: | Device |
| Product type: | Printer |
| Qualification level: | Certified for Microsoft Windows 10 Client family version 2004, x86 Certified for Microsoft Windows 10 Client family version 2004, x64 Signature Only - Windows Server 2008 family, x86 Signature Only - Windows Server 2008 family, x64 Signature Only - Microsoft Windows Vista family, x86 Signature Only - Microsoft Windows Vista family, x64 Signature Only - Microsoft Windows XP family, x86 Signature Only - Microsoft Windows XP family, x64 Signature Only - Microsoft Windows 2000 family Certified as Declarative INF |
| Marketing name: | N/A |

3. How To Use This Guide

3.1 Informative Icons

The following icons are used in this manual to highlight important information:

| | |
|---|--|
|  | Information providing further details or depth about specific points in the main text of the guide. |
|  | Warning Actions that are prohibited or dangerous to the product (loss of data, for example) or the user (safety matter, for example). |
|  | The term attached to this icon has a definition in the glossary provided in the present guide. |
| USE CASE | Examples of use cases are provided throughout this user guide. They will help you understand how to use Evolis Premium Suite and print your cards the best way. |
|  | Indicates that a video showing the procedure is available on www.evolis.com website. |

3.2 Glossary

| Term | MEANING |
|----------------------------|---|
| Anti-aliasing | Type of smoothing technique that is specifically focused on text areas and pictures. This settings is only available in Evolis card design softwares (Cardpresso). |
| Black dot | Dots of the design that have RGB colors <253 and are printed with the K panel only. The threshold detected by Evolis driver for black and colored dots is RGB 253. Colored dots have RGB color ≥253 and are printed with the YMC panels. If necessary, this threshold may be changed in your card designing software. |
| Clustered dithering | Halftoning technique that converts a color image to one made up of group of dots. It produces a good quality image rendering at distance |

| Term | MEANING |
|-----------------------------------|---|
| Composite Black | Process used to print the black color with a mix of colors: yellow, magenta and cyan |
| Dithering | Halftoning technique in which dots or pixels arrangement allows to perceive more colors than are actually used. |
| dpi (dot per inch) | Number of dots that are placed in one inch on a card design. |
| Duplex | Mode linked to a printer equipped with a flip-over module Automatic front and back-side printing is possible |
| Dye sublimation | Printing process in which ink is transformed in gas and spread on the card surface. Dyes of three separate color panels (YMC or Yellow, Magenta, Cyan) are used to create millions of colors within the spectrum, from white to (non-pure) black. Printing quality is dependent of the card quality, plastic composition and density. |
| Encoding | Process to save data on a specific support (magnetic stripe, contact/contactless chip). No confusion should be made with the term "encryption". Some encoding systems are called "dual" : it means they offer contact as well as contactless encoding CL means "contactless" CNT means "contact" |
| Encryption | Process to replace data by another data that can be encrypted/decrypted through a specific key. For example, the key may be as follows: replacing the letter by the letter +2 in the alphabet: A=C, B=D, C=E, D=etc. |
| EPC (Evolis Print Center) | Tool used to configure the system, manage printers and supervise printing jobs. |
| EPS (Evolis Premium Suite) | Driver suite that includes many software components used to manage printing jobs on the following printers: - Primacy - Primacy lamination - Zenius - Elypso - KC200/200B - KM500B/KM2000B |
| Evolis Printer Manager | Tool that uses notifications to provide an information or warn the user in case of issue or alert. |
| Evolis Printer Properties | Printing settings adapted to Evolis printers and that can be accessed in all installation modes of the EPS. |
| Halftoning | Process that simulates shades of gray by varying the size of tiny black dots arranged in a regular pattern (only available with a black ribbon) |

| Term | MEANING |
|--|--|
| Hologram | Advanced form of photography that allows an image to be recorded in three dimensions |
| Lamination | <p>Process that consists in applying a polyester film onto a card surface to protect it from wear and tear, UV rays, and to fight forgery. As applying a lamination film requires a higher temperature than the printing process, a specific lamination module is used.</p> <p>Lamination films are of two kinds: varnish or patch</p>  <p>Do not confuse the term varnish used for the lamination and same term used as a synonym of overlay. Please refer to overlay definition for more details.</p> |
| LCD (Liquid Crystal Display) | Color touchscreen attached to the Primacy printer that informs the user about the operational status of the printer and enables to change the most common settings. It also includes a switch on/off button to command the printer. |
| Native Driver | Simplified printer driver that is displayed and available by default through the computer Control Panel or directly from an application. It is called Unidriver on WINDOWS® |
| Native driver printing settings | Evolis graphical interface of the native driver, available in all three modes but particularly useful in Minimal Mode. The list of settings in this interface is limited, but they are the default settings when the printing job is not performed from an application with embarked settings |
| Overlay / Varnish | Film applied on the card after the printing process, to protect the card from UVs and to increase resistance of cards to scratching and fading up. It is applied through the "O"panel of the ribbon. |
| Panel | In a ribbon, sequence of colors that is repeated. The sequence of colors depends on the type of ribbon used. For example, in a five-panel ribbon, the colors are the following: yellow, magenta, cyan, black, overlay |
| Parallel mode | Default printing + lamination process when a printer and its lamination module are use combined to each other. In this mode, the process of card printing starts for a new card as soon as the previous card has been laminated. |
| Patch | <p>Type of lamination film available in thicknesses that enable a good durability of the card (12 microns > 3 to 5 years, 25 microns > 5 to 10 years).</p> <p>This type of film:</p> <ul style="list-style-type: none"> - does not cover the full surface of the card (near-to-edge covering) - is compatible with PVC or composite cards - is available as a translucent film or a as holographic film |

| Term | MEANING |
|--------------------------------------|--|
| PC/SC | Standard for smart cards and card readers. A smart contact card is a CR80 card with an integrated circuit. |
| Printing | Process made by the printer to apply the design on the card. Various techniques are used: - dye sublimation combined and thermal transfer - retransfer (only possible with Evolis retransfer printers) |
| Ribbon | Ink support film made of various panels or a continuous one, depending on the ribbon type. The film support can be a cassette or simple rolls. With Evolis High Trust® ribbons, a zone code provides authentication and identification of each ribbon. During the printing process, dye sublimation and thermal transfer techniques are used. |
| Simplex | Printer with no flip-over module integrated or activated. Front and back-side printing is possible, but the back-side print requires a manual action of the user |
| Smoothing | Technique used to make more even the curbs on the pattern, so as to get a clearer print rendering on the card. |
| Thermal transfer | Printing process in which ink is heated up to produce plastic resin and transferred onto the card surface. K (black) and O (overlay) panels are applied through this technique. For example, monochrome resin is applied on a YMC color design to produce a dense black text or a barcode. Card quality is less critical than for the dye sublimation process. |
| Varnish (used for lamination) | Type of lamination film available in a thickness that enables a two-year durability of the card This type of film: - covers the full surface of the card (edge-to-edge covering) - is compatible with PVC or composite cards - is not compatible with smart contact cards or magnetic stripe cards |
| YMCKO | Type of ribbon that contains the following panels: Yellow, Magenta, Cyan, Black, Overlay |

4. Overview of the EPS System

Evolis Premium Suite system is designed as follows:

EPS SYSTEM COMPONENTS

- Minimal Mode
- Supervision Mode
- Standard Mode

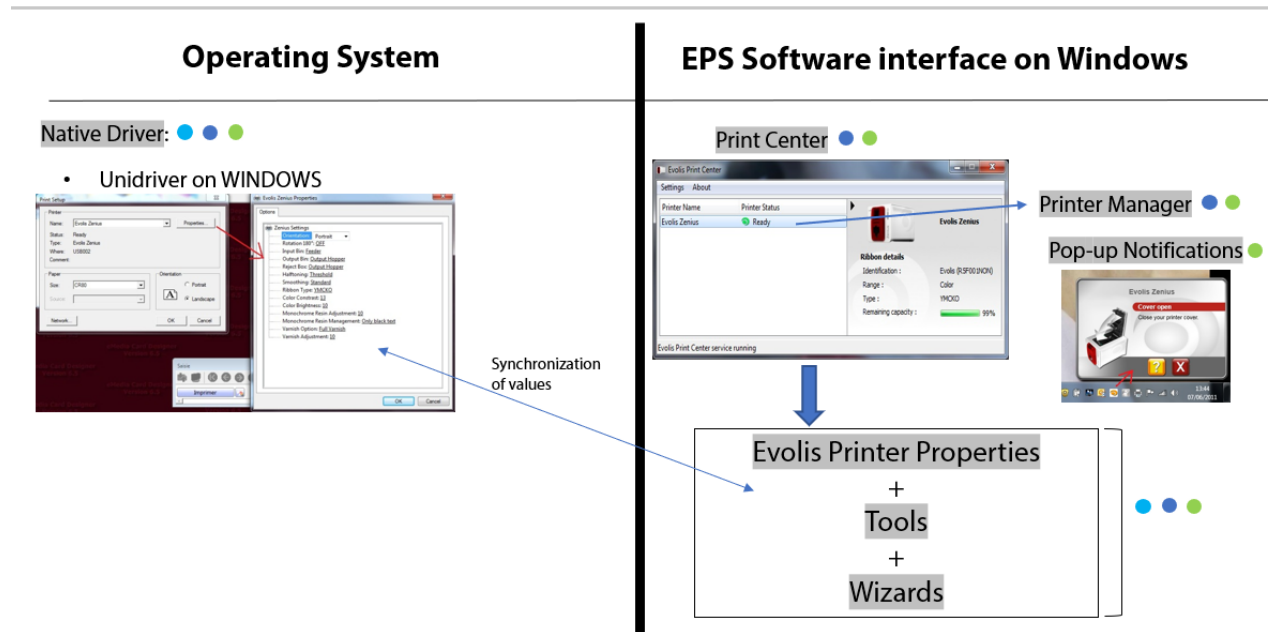

For more information on the modes of installation, refer to section [Three Modes](#) ²⁴.

4.1 Possible Configurations

All printers managed by Evolis Premium Suite have a USB port as well as an Ethernet port. Only Primacy printer has an additional Wi-Fi option.

The type of port used is different according to the configuration:

- one printer on one computer

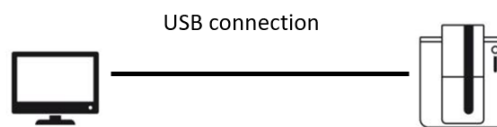

- various printers on the same computer

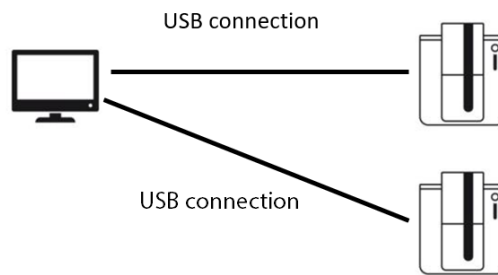

- printer shared between various computers

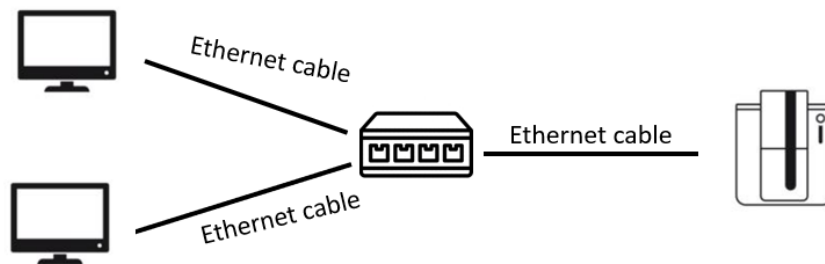

- through a switch: one or various printers with the Ethernet connection, on the same computer or various computers

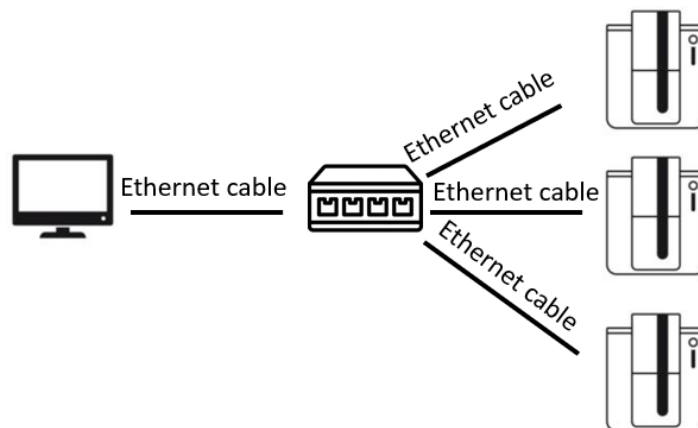

For more details on the installation and configuration steps, see section [Configuration of the Network](#)^[28].

5. Environment For The Suite

Before installing the Evolis Premium Suite on your computer, please check that you meet the requirements listed below.

5.1 Minimum Requirements

| | |
|-------------------------------|--|
| OPERATING SYSTEM | Windows 7 (32/64 bits) Windows 8 (32/64 bits) Windows 10 (32/64 bits) Windows Server 2019 (32/64 bit) Windows Server 2016 (32/64 bit) Windows Server 2012 R2 (32/64 bit) Windows Server 2008 R2 (64 bit) |
| AVAILABLE SIZE ON DISK | ≥1,8 MB |
| FIRMWARE | Last firmware available on Evolis website  The driver and the firmware applicable to your printer are closely linked. Please always make sure that the firmware installed on your computer is up to date. |
| RIGHTS | Administrative rights are compulsory on your computer. |
| NETWORK OPTIONS | USB, Ethernet or Wi-Fi connection (refer to section Configuration of the Network) ^[28] |

5.2 Languages Available

16 languages are available: German, English, Spanish, French, Italian, Dutch, Portuguese, Russian, Polish, Turkish, Japanese, Simplified Chinese, Traditional Chinese, Korean, Arabic, Farsi.

5.3 Meeting On Screen Colors and Card Colors

When customizing your card design on an Evolis card designing software or another support, you may have a difference of color between your design on the screen and what you get on your printed card.

To improve the correspondence between the on-screen rendering and the printed result, you can follow the two steps below:

- [Installing Evolis Color Profile on WINDOWS®](#)^[16]
- [Changing Printing Settings](#)^[19]

5.3.1. Installing Evolis Color Profile on WINDOWS®

Step 1: From the **Control Panel**, select the printer and click on **Printer properties**.

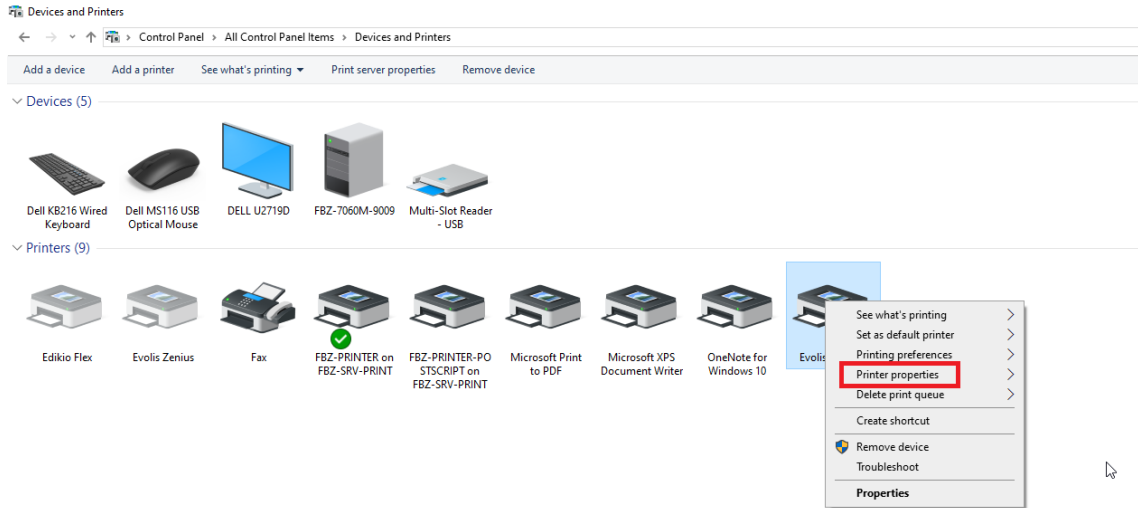

Step 2: Go to **Color Management>Color Management**.

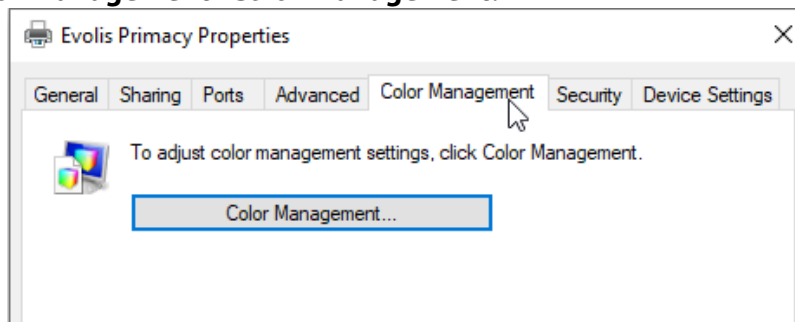

Step 3: In the **Device** field, select the printer.

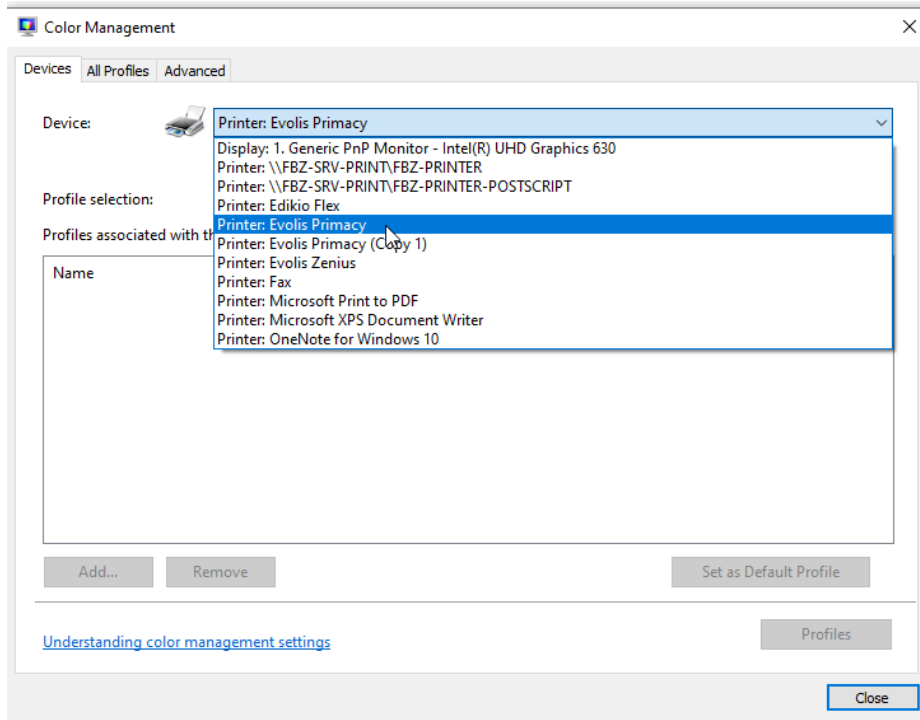

Step 4: Tick **Use my settings for this device**.

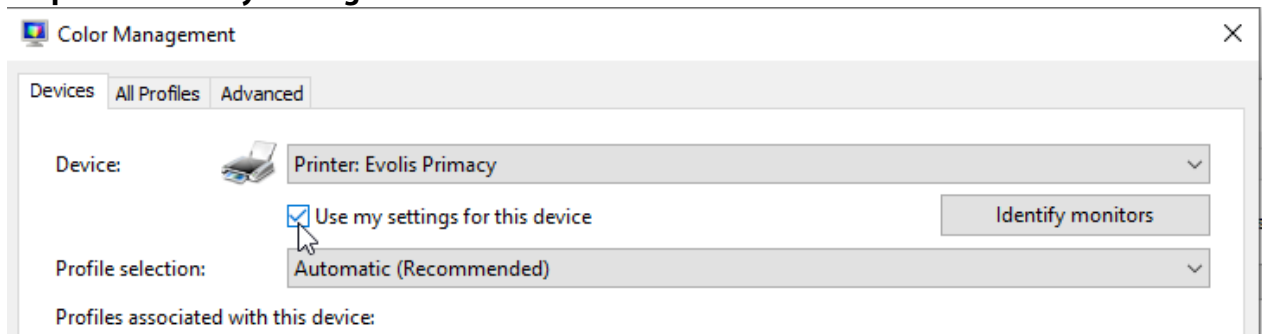

Click on **Profiles**.

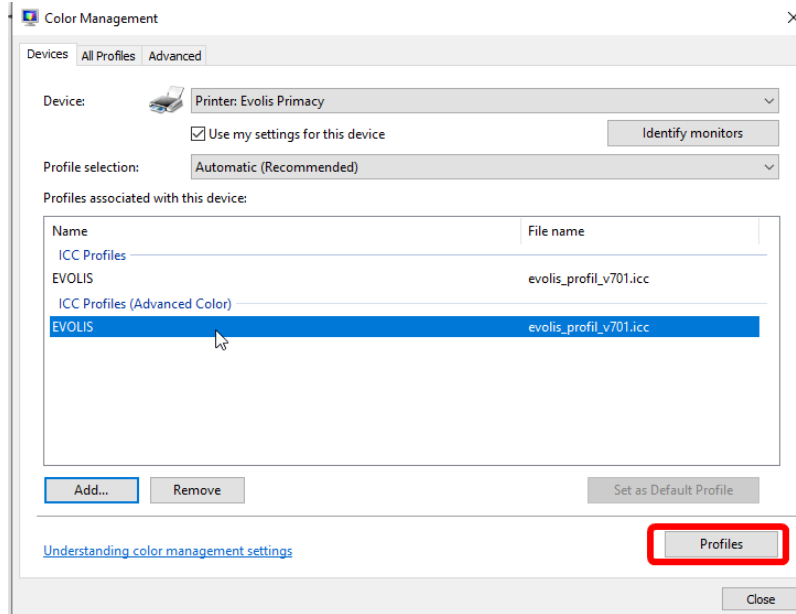

Step 5: Select the EVOLIS profile and click on **OK**.

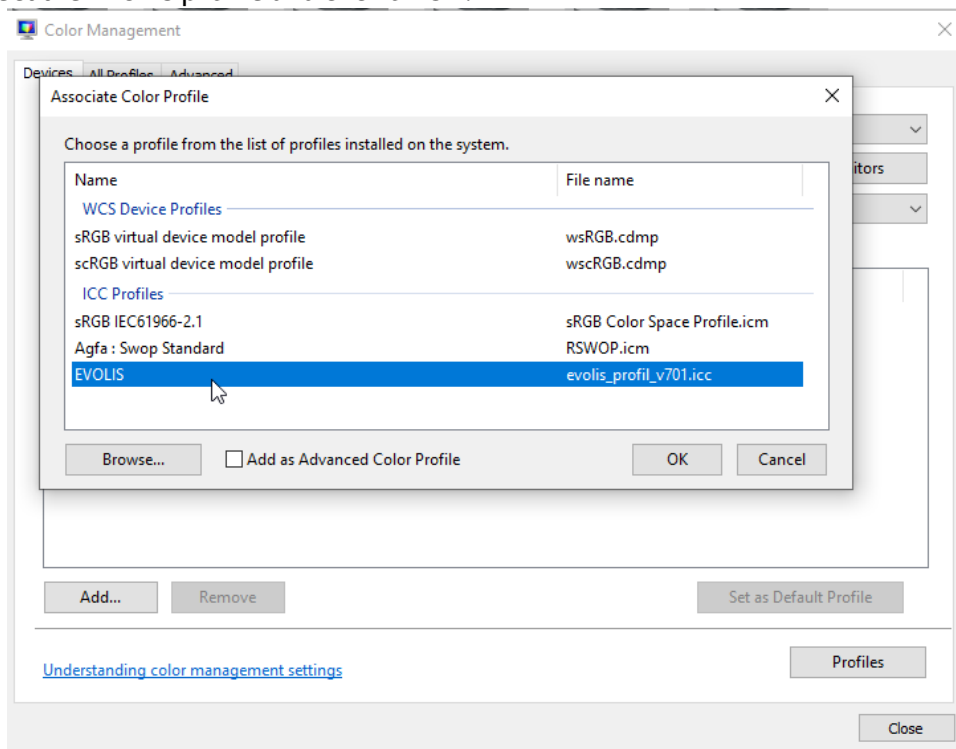

Example of card before and after applying the color profile:



If you use a specific graphic design software such as Photoshop, make sure to select **Printer Manages Colors** in the Print window.

If you select **Photoshop Manages Colors**, you may get differences between the on-screen rendering and the printing result.

5.3.2. Changing Printing Settings

From the list of printers available on your computer, right-click on the current printer and click on **Printing Preferences**.

Adjust the **Brightness** and **Contrast** of the printing. Please refer to section [Brightness and Contrast](#)⁸⁷ for more details.

6. Installation of Evolis Premium Suite

Please refer to section [Minimum Requirements](#)^[15] before starting the installation.

6.1 Checking Your Current Driver Version

Before you decide to change the driver on your computer, you can check your current driver setup version as follows:

Step 1: From the Print Center, double-click on the printer name to access its **Properties**.

Step 2: Click on **System details**, then **System details** again.

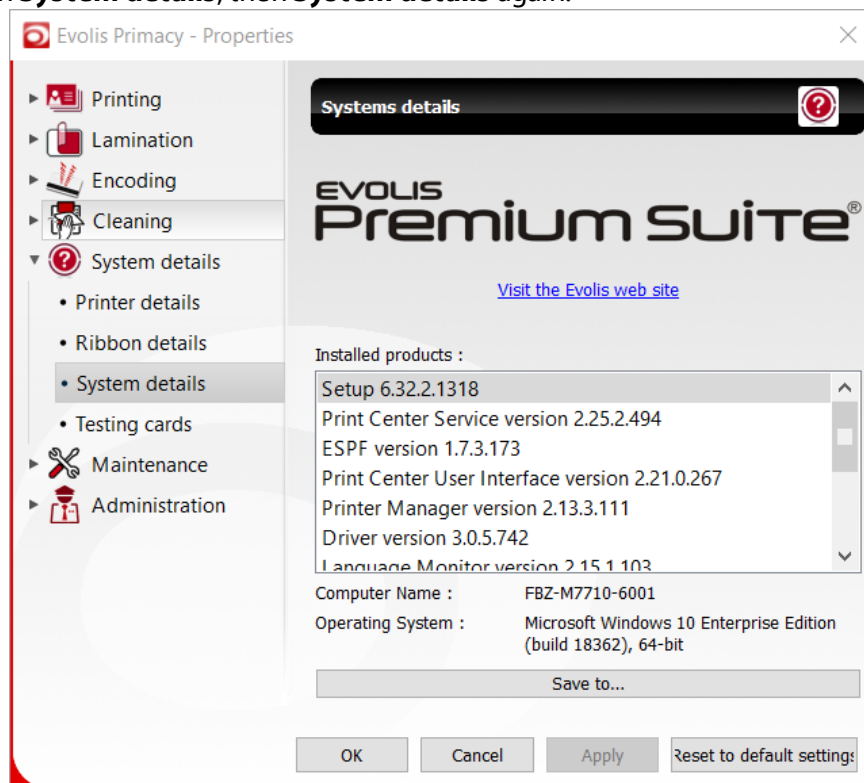

6.2 Finding the Driver Setup File

Step 1: Go to the [Evolis website](#), click on **Drivers&Supports** and select the printer that you are currently using, then click on **Drivers&Firmware**.

Evolis Premium Suite driver is made available through an .exe file.

Step 2: Click on the link called **Evolis Premium Suite - Setup** and click on the .exe file that is now stored in the **Downloads** folder.



Never plug-in the Evolis printer USB cable before launching the driver installation. The wizard will indicate when the USB cable can be plugged-in.

6.3 Running the Installation Wizard

- **In case of re-installation**, make sure to cancel all current case printing jobs that were launched before starting. Please refer to [Troubleshooting When Installing EPS](#) section for more details.

Step 1: From Windows explorer, go to **Computer>Downloads** and double click on the .exe file named **setup_evolis_premium_suite.exe**.



As some versions of Windows® require Administrator rights to install the EPS, make sure that you right-click on the .exe and click on **Run as an Administrator**.

In case you are asked to enter a password, it means that you do not own the Administrator Rights. In this case, please contact your internal IT service.

Step 2: Select the language you want to display for the installation wizard and click on **Ok**.

Step 3: If a previous version or the same version of the EPS driver was already installed on your computer, the following message is displayed:

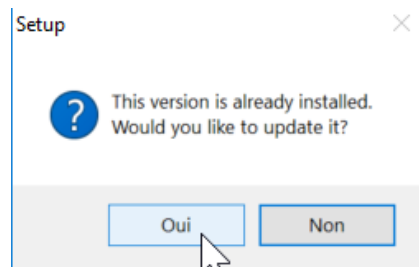
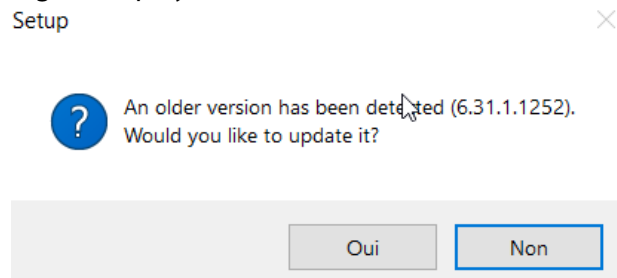

Step 4: Click on **Yes** to confirm the update of the EPS version. The welcoming window is now displayed.



To avoid any installation issue, it is strongly recommended to close all other application before going on with the EPS installation process.

TIP: When closing all other open applications, if you have temporarily lost the EPS driver

window, you can find it in the taskbar, with the following icon:

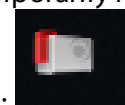

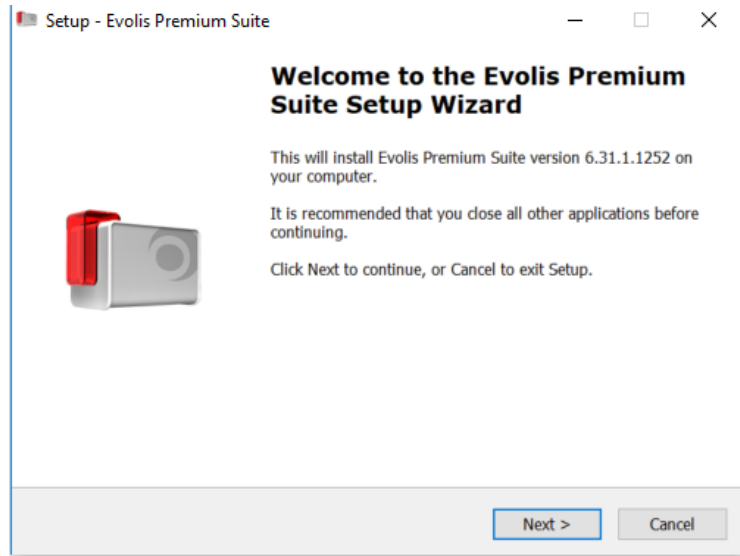

Step 5: Click on **Next** to continue. The **Warranty Agreement** window is now displayed:

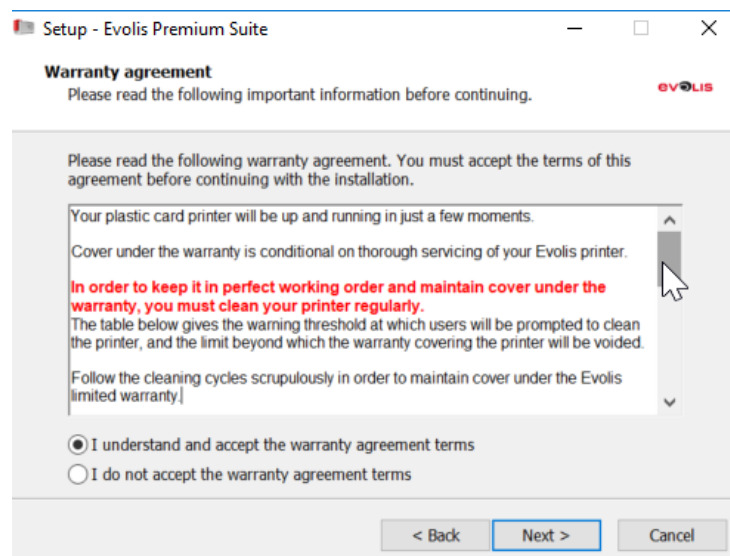

Please make sure to read its content carefully. It provides useful information on the warning thresholds for the cleaning of each supported printer.

Step 6: After carefully reading the content, tick **I understand** and accept and click on **Next**. An important information is now displayed.



If you have already connected the USB cable between the printer and your computer, please make sure to disconnect it.

Step 7: Click on **Next** to continue. In the next window, you will have to select the installation mode for the EPS driver.

- In case of first installation, you are offered the possibility to run the wizard in order to install the printer in network (Ethernet or Wi-Fi).

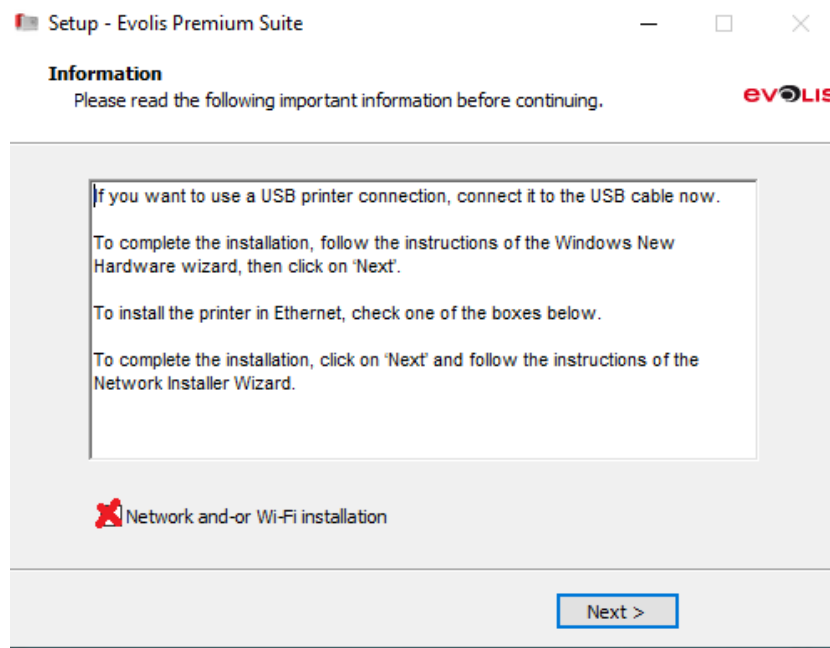

Tick this option and refer to sections [LAN Connection](#)^[28] and [Wi-Fi Connection \(Primacy printer only\)](#)^[42] for all configuration steps.

6.4 Troubleshooting When Installing EPS

When re-installing Evolis Premium Suite, an error message is displayed saying that current printing jobs prevent the full installation.

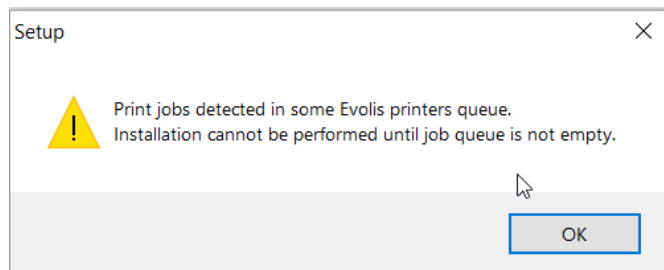

In this case, follow the steps below:

Step 1: Go to **Control Panel>Printers and Scanners**

Right-click on each printer to display the current printing jobs.
Delete the printing jobs that are in the waiting list.

Relaunch the setup to re-install the EPS.

Step 2: If this procedure does not solve the issue, then go back to **Panel>Printers and Scanners**. Right-click on each printer displayed and click on **Remove device**.



The printer will appear again in the list next time you connect it to the computer.

Step 3: Relaunch the setup to install the Evolis Premium Suite.

6.5 Three Modes

Evolis Premium Suite offers three modes of installation.

By default, the **Standard Mode** is selected, as it is recommended for most printing contexts. However, the two other modes may apply to specific contexts.

Please refer to section [Overview of the EPS system](#)^[13] for more information on the components available, their description and interdependency.

| MODE OF INSTALLATION | COMPONENTS & SERVICES | CONTEXT OF APPLICATION |
|--|---|--|
| Standard Mode ^[25] | Native driver, Tools, Print Center, Printer Manager | 1 computer connected to 1 printer USB connection Wi-Fi connection |
| Minimal Mode ^[26] | Native driver, Evolis Printer Properties, Tools | 1 computer connected to ≥ 1 printer ≥ 1 computer connected to 1 printer (direct connection or through a switch/router) Ethernet connection Wi-Fi connection Useful to avoid the collision of messages on the network. But many automatic features are not available. For example, on a printer that does not have LED indications, if you forget to insert the card in the feeder, no reminder will appear and the printing job will not be launched. |
| Supervision Mode ^[25] | Native driver, Tools, Print Center, Printer Manager (without notifications) | Printer integrated in a customer global equipment (for example, a banking kiosk) |

To install a specific mode, please click on the corresponding sections in the table.

6.5.1. Standard Mode

This is the installation mode recommended by Evolis: this solution offers the best display of information on the printer status for the user.

With this mode, the user can make sure its printer is in operable condition. Thus, no consumable will be wasted unnecessarily.

In this mode, the communication between the driver and the printer is bidirectional.

All available components are installed:

| Component | Section with explanation on parameters |
|---------------------------------|---|
| Native Driver Printing Settings | Native Driver Printing Settings (all installation modes) 58 |
| Tools | Tools 66 |
| Print Center | Using the Print Center (Standard and Supervision Modes) 62 |
| Printer Manager | Printer Manager 64 |

6.5.2. Supervision Mode

The **Supervision Mode** offers the same possibilities as the **Standard Mode**.

It simply does not include the Printer Manager: no pop-up notification will be displayed in case of problem.

This mode is particularly useful in contexts when pop-up notifications would be intrusive (for example, banking kiosk).

Nevertheless, the troubleshooting/details linked to the notifications can be viewed when right-clicking on the printer name in the Print Center.

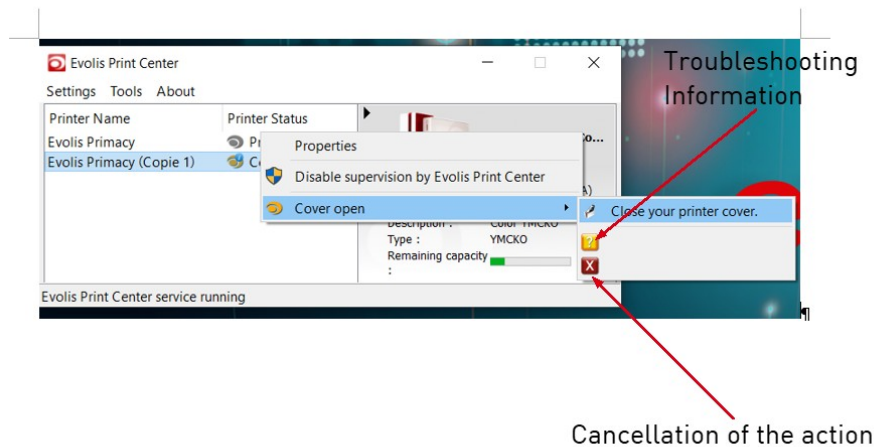

6.5.3. Minimal Mode

On Windows®, the minimal mode is used with an Ethernet connection and it enables to connect various printers to the same computer or to share the same printer among various computers.

In this mode, the communication with the printer is one-way only (from driver to firmware, or in other words, from computer to printer).

This mode is particularly adequate to avoid the collision of commands and notifications on the network, which may be caused by the launch of various jobs at the same time and from various printers.



In Minimal mode, all settings must be customized manually, whenever the printing configuration has changed.

For example, as there is no automatic detection of the ribbon, do not forget to check and set the ribbon before printing a job and each time you change the ribbon.

Please refer to sections [Native Driver Printing Settings \(all installation modes\)](#)^[58] and [Evolis Printer Properties \(all installation modes\)](#)^[62] to manage the driver properties in minimal mode.



Print settings are changed **from native driver printing settings** => they apply on all printing jobs of the selected printer

Print settings are changed **from the card designing application** => they apply on the current printing job only

Thus, accessing one or the other interface depends on your needs.

6.5.3.1. Installation and Access to Printing Settings

On Windows®, the Minimal Mode can be selected when installing the Setup. When the minimal mode is installed, and if you have checked the option, the shortcut on your



desktop is the following:

If the option was not checked, you can access the same window through **Start>Evolis Card Printer>Evolis Printer Properties**

Evolis Printer Properties are accessed through **Start Menu>Evolis Card Printer** folder of your computer, in all three modes (minimal, standard and supervision).

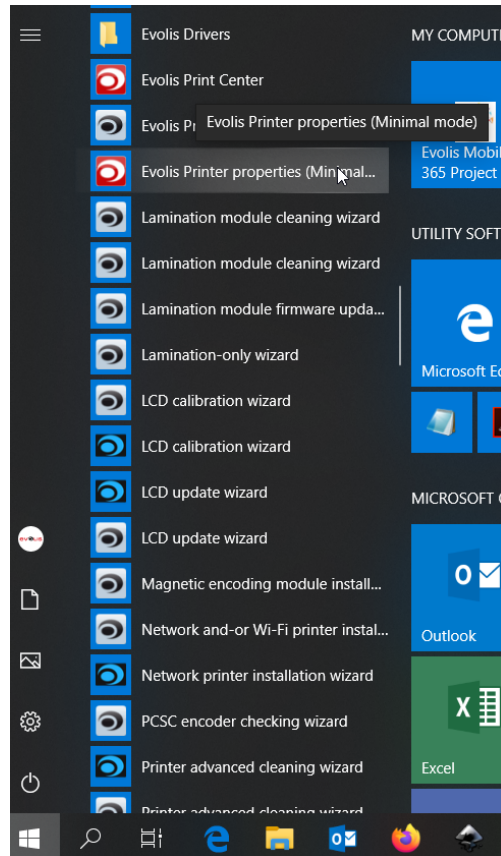

All wizards available in the Print Center are also in this list (in Standard Mode, wizards are in the **Tools** section of the Print Center)

You also have access to the native driver. Please refer to section [Changing Print Settings Through Native Driver: Use Cases](#) for more information.

6.6 Configuration of the Connection

This section explains how to configure your printer(s) and computer(s) through different types of connections (point-to-point or network) and communication (USB, Ethernet, Wi-Fi).

You may have some additional information in the following document: [Network Administrator Manual](#).

6.6.1. USB Connection

This type of connection is the most frequently used.

You can use it with:

- one printer

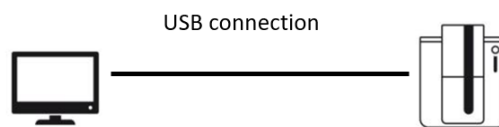

- various printers: depending on the number of USB ports on your computer

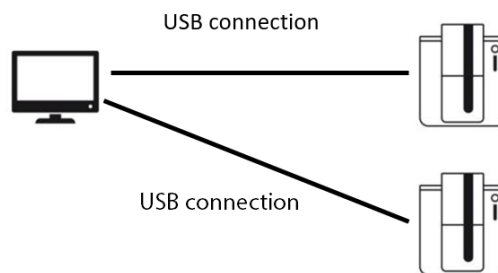

All installation modes (minimal, standard and supervision) of the Evolis Premium Suite are adequate with those configurations.



If you use a USB switch, please be aware that all models are not supported by Evolis configurations today.

6.6.2. LAN Connection

This type of connection uses Ethernet ports and cables.

It is used when a printer is shared on various computers, or various computers use share the same printer.

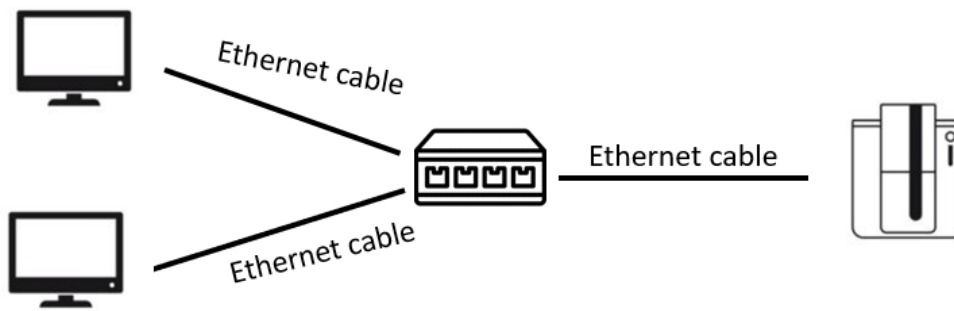

With this type of configuration:

- only the **Minimal Mode** is adequate (as supervision cannot be provided by the Print Center on various computers at the same time)
- only magnetic encoding is managed. There is no smart encoding nor contactless encoding.

6.6.2.1. Checklist Before Starting

- Do not plug at the same time the USB cable and the network cable.
- Firewall and Antivirus : must be set to authorize communication on port 9100 (Evolis raw printing port). You must have at least "power user "rights to perform Evolis network printer installation.
- IPV4 protocol: Evolis printer is compliant with IPV4 communication protocol only (not IPV6).
- Multicast: pay attention that the protocol used to discover the printer on a network is multicast so then the routing table on your network equipment (router, server ...) must be configured accordingly to your network architecture to allow communication.
- Broadcast, HTTP, HTTPS and ICMP dedicated ports must be allowed.
- Led Status at the rear of the Evolis printer must be as in the following example:

Primacy example



Green LED

On = 10Mbit/s
Off = 100Mbit/s

Orange LED

On = Printer connected to network
Blinking = Printer connected and network traffic is working

6.6.2.2. Setting a Fixed IP Address on the Printer

By default, printers do not have a configured IP address. You need to configure it manually.

6.6.2.2.1. Collecting the Required Information

Make sure you have access to the following information:

- IP address of your computer network card (ex: 192.168.1.23)
- Subnet mask of your computer network card (ex : 255.255.255.0)



In most situations, you will need to request those settings to IT department or technical team of the company where you plan to install the Evolis Network printer.

6.6.2.2.2. Configuring your Printer IP Address

Step 1:



For this first step, your printer must be connected to the computer through a USB cable.

Go to Command Prompt to check if the printer already has an IP address and to configure it if necessary: click on **Windows>Start**, then type **cmd** in the search field on this prompt and press **Enter**



Be extremely careful with the characters. The presence/ absence of spaces and capital letters is important.

Enter the commands:

1.Type "cd", then the path example for default location of the evocom.exe utility (communication tool) folder

cd "C:\Program Files\Evolis Card Printer\Evolis Premium Suite\Tools"

2. type **EvoCom -p"Evolis Primacy" Rip** to read the IP address



You can also check the IP Address through **Printer Properties>System Details>System Details>Save**. Open the .txt file to check the IP address.

3. to configure the IP address, enter **EvoCom -p"Evolis Primacy" Pip;192.168.2.13** (example of IP address)

4. to configure the subnet mask , enter **EvoCom -p"Evolis Primacy" Penm;255.255.255.0** (example)

```

Command Prompt
Microsoft Windows [Version 10.0.18362.1082]
(c) 2019 Microsoft Corporation. All rights reserved.

C:\Users\acarchereux_services>cd "C:\Program Files\Evolis Card Printer\Evolis Premium Suite\Tools"

C:\Program Files\Evolis Card Printer\Evolis Premium Suite\Tools>EvoCom -p"EvolisPrimacy" Rip

C:\Program Files\Evolis Card Printer\Evolis Premium Suite\Tools>EvoCom -p"Evolis Primacy" Rip
192.168.1.2

C:\Program Files\Evolis Card Printer\Evolis Premium Suite\Tools>EvoCom -p"Evolis Primacy" Pip;192.168.1.1
OK

```

Step 2: Connect the Ethernet cable.

6.6.2.3. Finishing the Detection of the Printer

Step 1: Make sure the Ethernet cable is connected between the computer and the printer, then use the **Network/Wifi wizard** to finish the configuration.

To access the wizard:

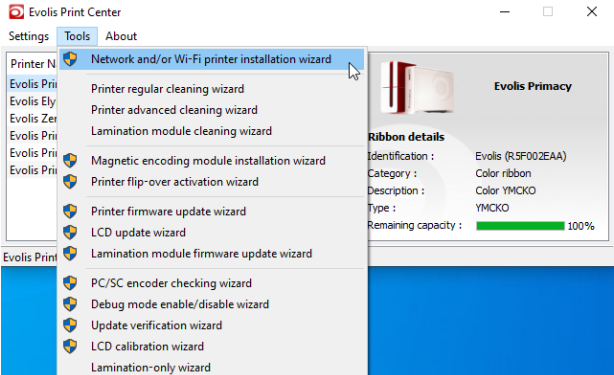
| in Standard/Supervision Mode | in Minimal Mode |
|---|--|
| <p>From the Print Center, click on Tools>Network and/or Wi-Fi printer installation wizard</p>  | <p>Click on Windows Start>Evolis Card Printer>Network and/or Wi-Fi printer installation wizard</p> |

Step 2: In the wizard, select **Fixed IP or DHCP network installation** and click on **Next**.

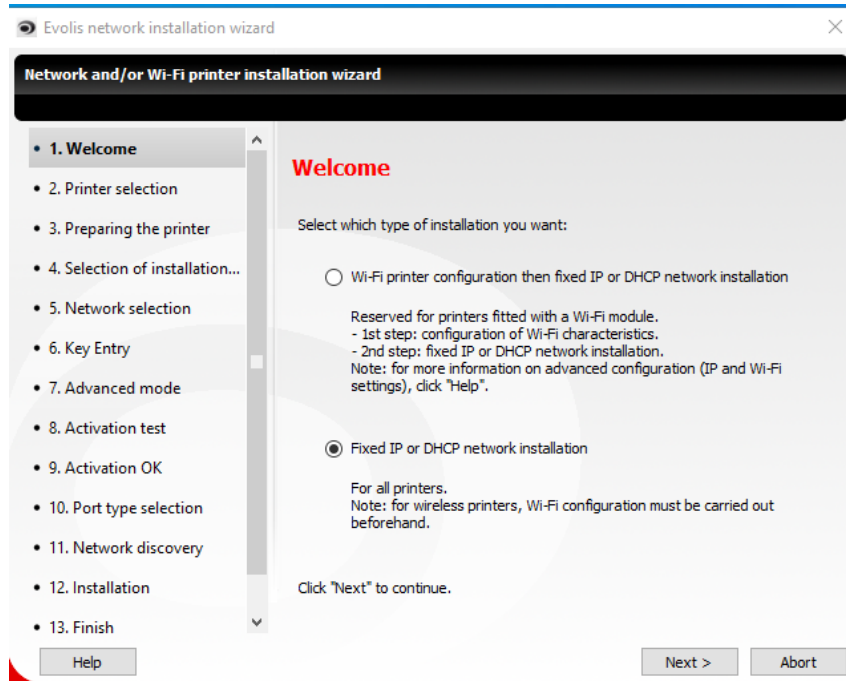

Step 3: Select **Static IP** in the next window.

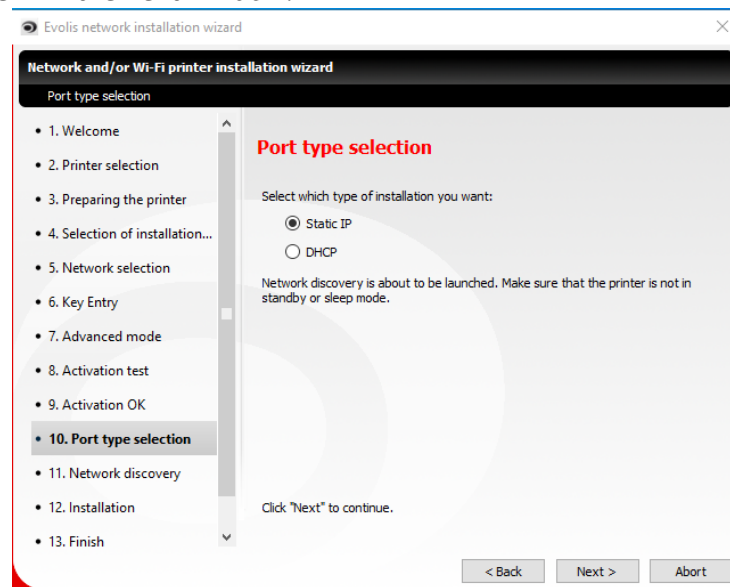

Step 4: The printer is detected in the following window.

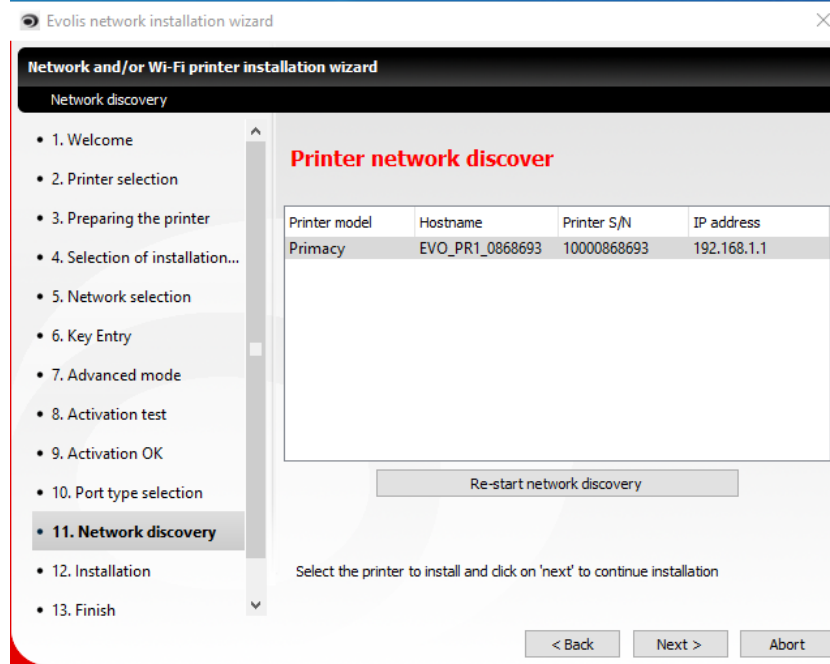

Step 5: In the Installation window, make sure to change the name of the printer:

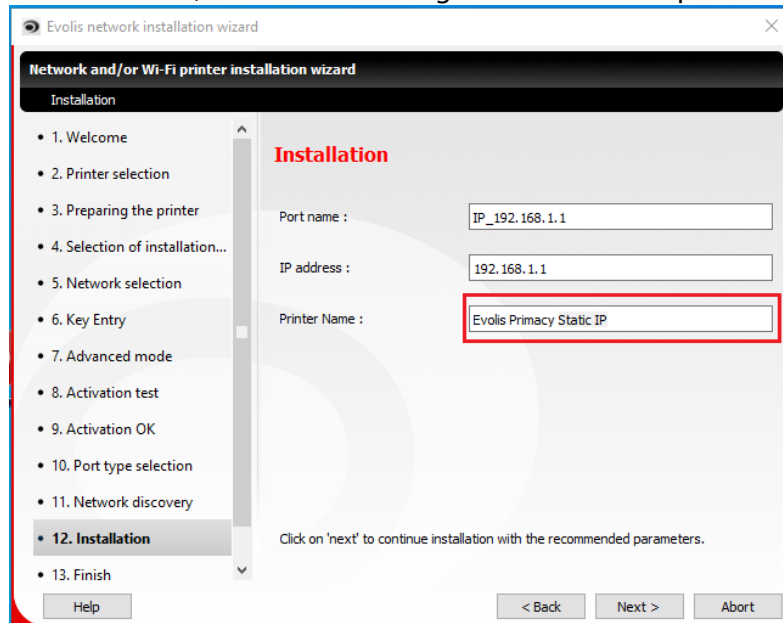

Step 6: Click on **Next**. Possible results are the following:

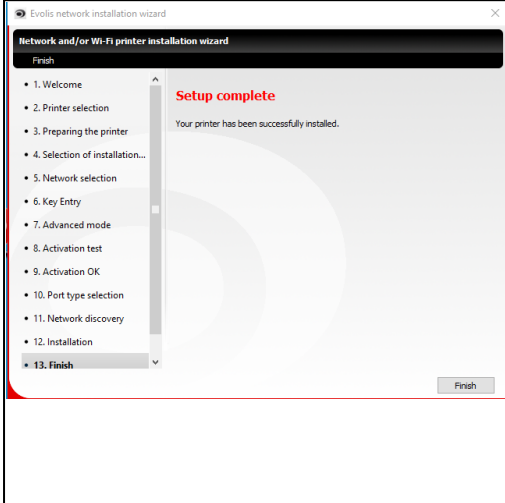
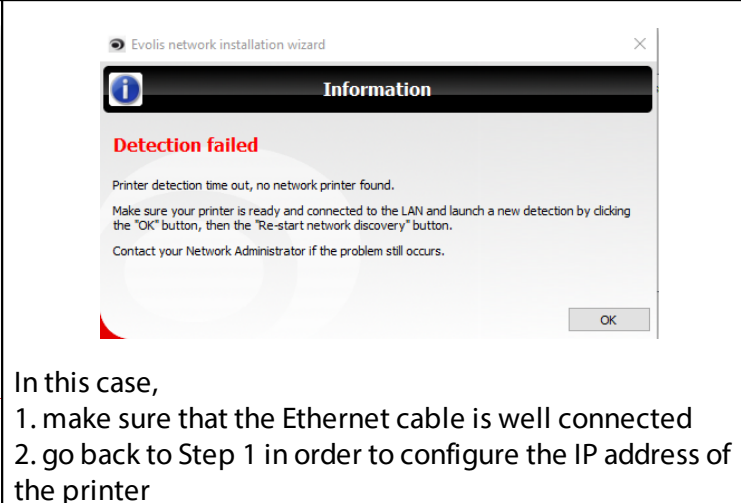
| Setup is complete | Detection of the printer failed |
|---|--|
|  |  <p>In this case,</p> <ol style="list-style-type: none"> 1. make sure that the Ethernet cable is well connected 2. go back to Step 1 in order to configure the IP address of the printer |

Step 7: You can now unplug the USB cable. To check that the IP address on the printer is well configured, go to [Checking Connection With the Printer](#)^[41].

Step 8: Restart the computer. Unplug the printer and plug it again.

6.6.2.3. Setting a DHCP Address on the Printer

You may want to use the DHCP configuration if you use a switch to connect one or various printers (and/or computers) to a DHCP server (see section [Using a Switch](#))^[40].

6.6.2.3.1. Configuring DHCP address

By default, Evolis printer are configured in DHCP mode. But if you have already changed this mode into a static IP address and you want to go back to a DHCP address, then follow the procedure below.

Step 1. Connect printer and computer through the USB cable. The EPS must be installed in Minimal Mode on the computer(s).

Step 2. Configure the printer in DHCP mode. You can choose the configuration that best suits you:

Option #1: Set the address manually

Go to Command Prompt: click on **Windows>Start**, then type **cmd** in the search field on this prompt and press **Enter**



Be extremely careful with the characters. The presence/ absence of spaces and capital letters is important.

Enter the commands:

1. Type "cd", then the path example for default location of the evocom.exe utility (communication tool) folder

cd "C:\Program Files\Evolis Card Printer\Evolis Premium Suite\Tools"

2. type **EvoCom -p"Evolis Primacy" Rip** to read the IP address

3. enter **EvoCom -p"Evolis Primacy" Pip;DHCP**

4. Enter Rip;1. The answer must be [IP address] Auto (see the example below)

```
C:\Program Files\Evolis Card Printer\Evolis Premium Suite\Tools>EvoCom -p"Evolis Primacy" Rip
192.168.2.1

C:\Program Files\Evolis Card Printer\Evolis Premium Suite\Tools>EvoCom -p"Evolis Primacy" Pip;DHCP
OK

C:\Program Files\Evolis Card Printer\Evolis Premium Suite\Tools>EvoCom -p"Evolis Primacy" Rip;1
11.1.24.28 Auto

C:\Program Files\Evolis Card Printer\Evolis Premium Suite\Tools>
```

5. to configure the subnet mask , enter **EvoCom -p"Evolis Primacy" Penm;255.255.255.0** (example)

Option#2: Reset factory configuration

- From **Command Prompt** or **Maintenance** menu:

Type Rmp;E

It will reset the DHCP configuration and disable the Wi-Fi option (if available)

- You can also reset the configuration through a long push on the switch on/off button of the printer.

Option #3: Enable DHCP mode

- through the LCD screen

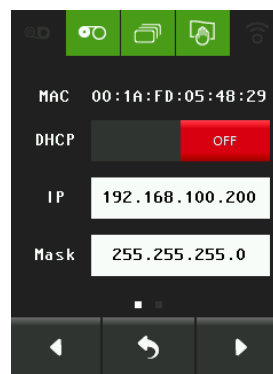
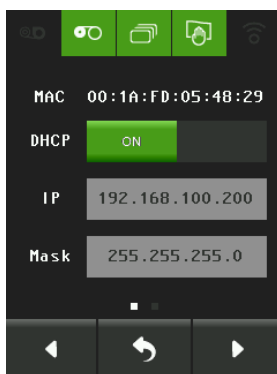

- through the Web interface

Open a Web browser, type the IP address of the printer and type on **Enter**.

In **Network** tab, click on **Enable**

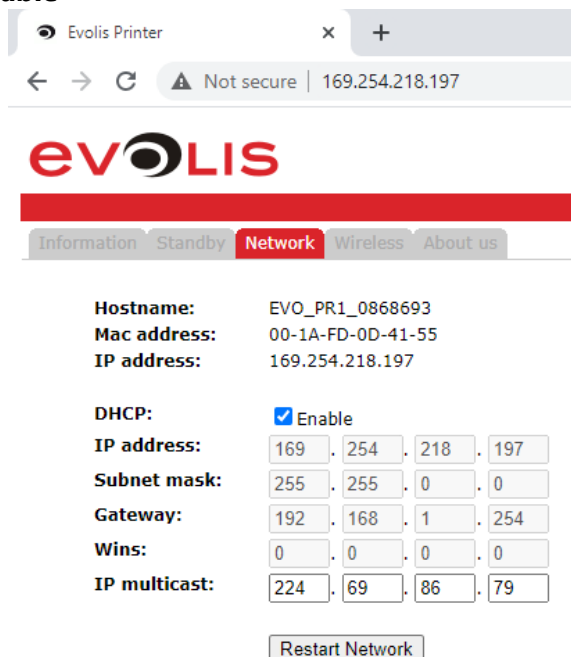

Step 3: Unplug the USB cable and install all the hardware equipment (please refer to diagrams in section [Using a Switch](#)⁴⁰). Make sure the printer is switched on and the Ethernet cables are plugged.

Step 4: Check the connection with the printer (more details in section [Checking Connection With the Printer](#)⁴¹)

6.6.2.3.2. Detecting the Printer through the Wizard

Step 1: Use the **Network/Wifi wizard** to finish the configuration.
To access the wizard:

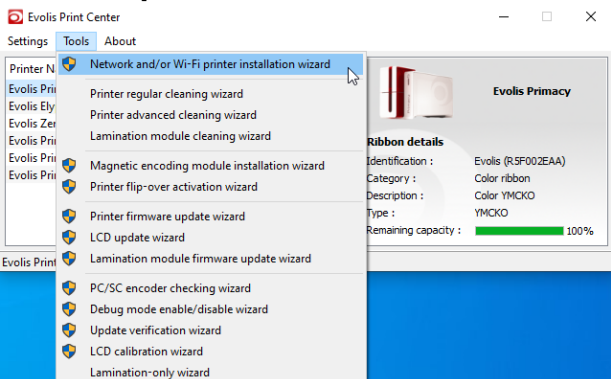
| In Standard/Supervision Mode | In Minimal Mode |
|---|---|
| <p>From the Print Center, click on Tools>Network and/or Wi-Fi printer installation wizard</p>  | <p>Click on Windows Start>Evolis Card Printer>Network and/or Wi-Fi printer installation wizard</p> |

Select the DHCP option and start the printer detection.

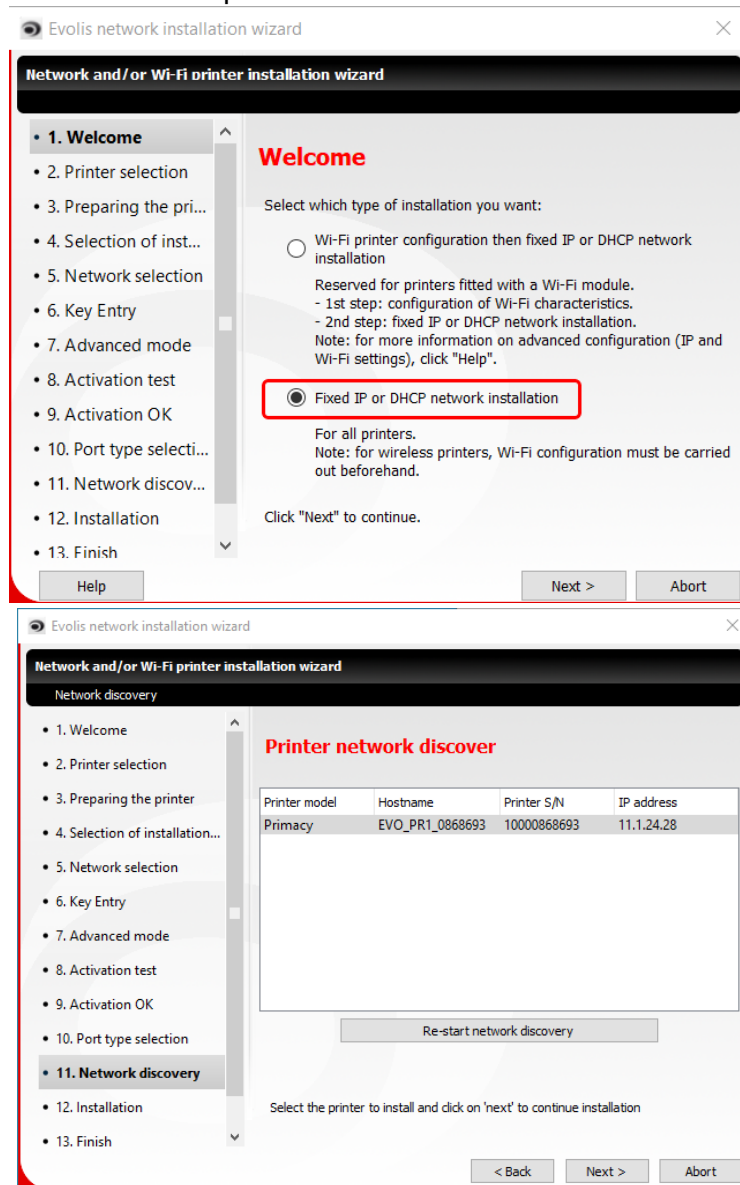

Change the name of the printer:

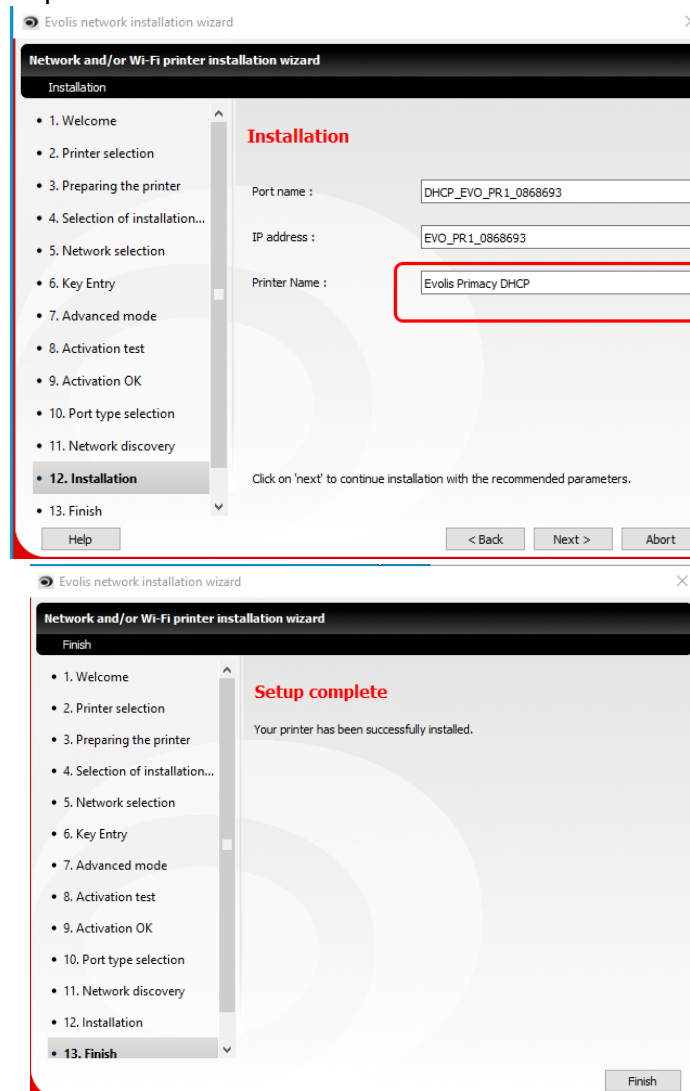

Step 6: Start a printing job.

Step 7: Follow steps 1 to 6 to add as many printers as necessary



If you have detection issues, please refer to [Troubleshooting: Connection Issues](#) ¹⁵³

6.6.2.4. Using a Switch

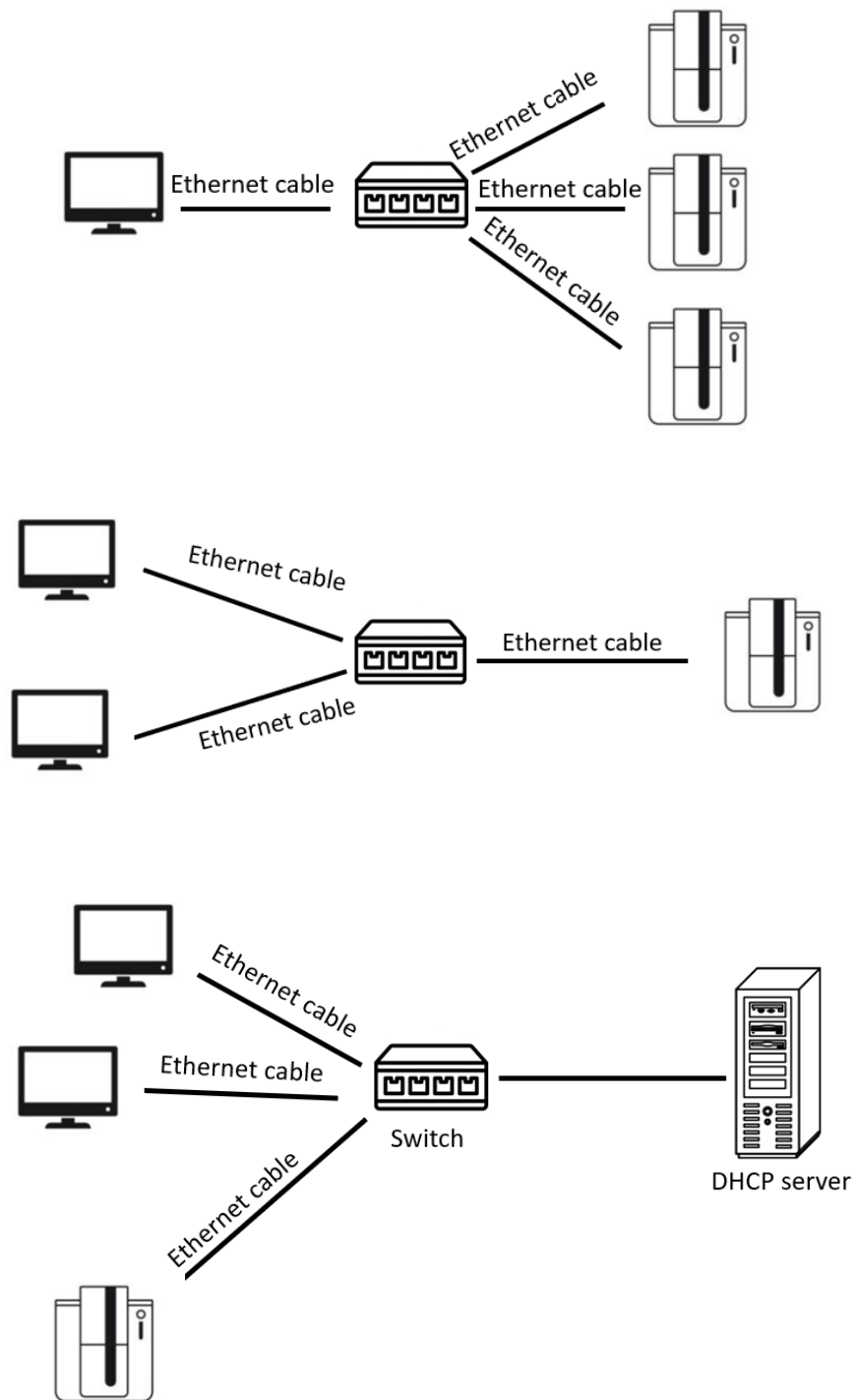

Use the:

- DHCP protocol if your switch is connected to a DHCP server ([Network Environment: DHCP Address](#))^[34]
- fixed IP address otherwise ([Setting a Fixed IP Address on the Printer](#))^[30]

6.6.2.5. Checking Connection With the Printer

6.6.2.5.1. Maintenance Menu of Printer Properties

The **Maintenance** Menu of Evolis Printer properties enables you to send commands to the printer.

For examples of commands, please refer to section [Printer Commands Prompting](#)¹⁴⁴.

6.6.2.5.2. Web Interface of the Printer

Open a webpage and enter the **IP address** of the printer in the search field and type on **Enter**.

The page displayed is the following:

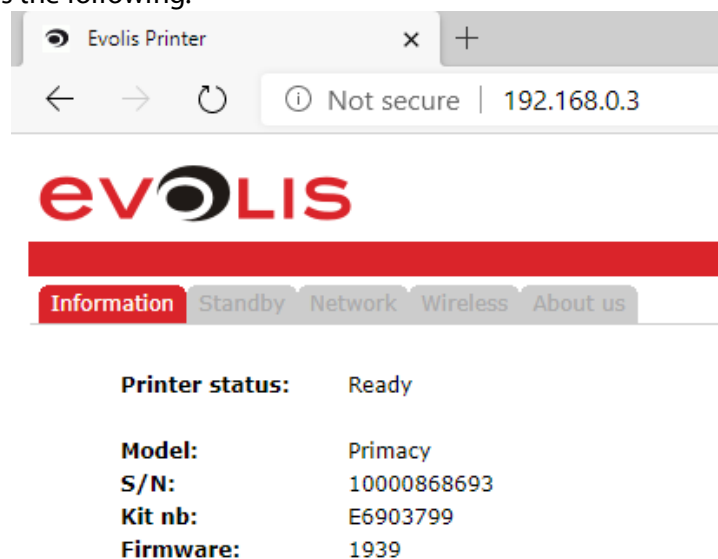

Accessing this page means that your computer is connected to the printer.

If this page is not displayed, go to [Troubleshooting](#)¹⁵³ section.

6.6.2.5.3. Ping Command

Click on **Windows>Start**, then type **cmd** in the search field on this prompt and press **Enter**.

Enter the commands:

1. Type "cd", then the path example for default location of the evocom.exe utility (communication tool) folder

cd "C:\Program Files\Evolis Card Printer\Evolis Premium Suite\Tools"

2. Type **ping 192.168.1.1** (example of IP address)

```
C:\Program Files\Evolis Card Printer\Evolis Premium Suite\Tools>ping 192.168.1.1

Pinging 192.168.1.1 with 32 bytes of data:
Reply from 192.168.1.1: bytes=32 time<1ms TTL=100
Reply from 192.168.1.1: bytes=32 time=1ms TTL=100
Reply from 192.168.1.1: bytes=32 time=13ms TTL=100
Reply from 192.168.1.1: bytes=32 time=12ms TTL=100

Ping statistics for 192.168.1.1:
    Packets: Sent = 4, Received = 4, Lost = 0 (0% loss),
    Approximate round trip times in milli-seconds:
        Minimum = 0ms, Maximum = 13ms, Average = 6ms
```

3. If the answer is as written in the screenshot above, then the ping test is positive and the computer can communicate with the printer.
If not, go to [Troubleshooting](#)¹⁵³ section.

6.6.3. Wi-Fi Connection (Primacy printer only)

Pre-requisites :

- availability of a Wi-Fi network
- frequency of Wi-Fi network must be compatible with the printer Wi-Fi card
 - Connect1: 2.4 GHz
 - UBox: 2.5 GHz/5 GHz

6.6.3.1. Choosing and Checking the Type of Connection

If you plan to use a fixed IP connection, please refer to section [Setting a Fixed IP Address on the Printer](#)³⁰

If you plan to use a DHCP connection, please refer to section [Setting a DHCP Address on the Printer](#)³⁴.

Please make sure that your computer network card is also configured adequately.

6.6.3.2. Checking the Availability of Wi-Fi Option in the Printer

From Evolis Premium Suite, go to **Printer Properties**>**Maintenance**.

Step 1: In the **Command** field, enter **Rtp;w**

When the **Answer** is **1**, it means the WiFi option is installed in the printer.

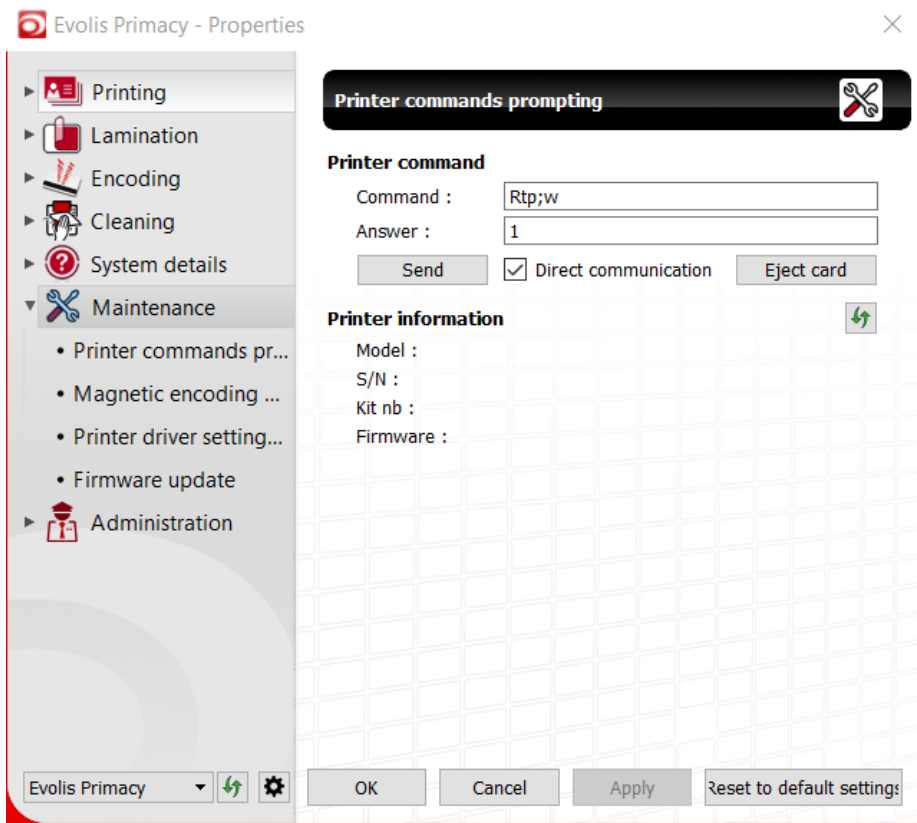

Step 2: Check the indication on the LED panel or LCD  panel



If the icon is displayed and lit on the LED panel or LCD panel



, go to [Performing the Detection of the Printer in Wi-Fi](#) ⁴⁴

If the icon is not available, it means the Wi-Fi option is not detected by Evolis Premium Suite. In this case, please contact the [support](#) team.

6.6.3.3. Performing the Detection of the Printer in Wi-Fi

To access the wizard:

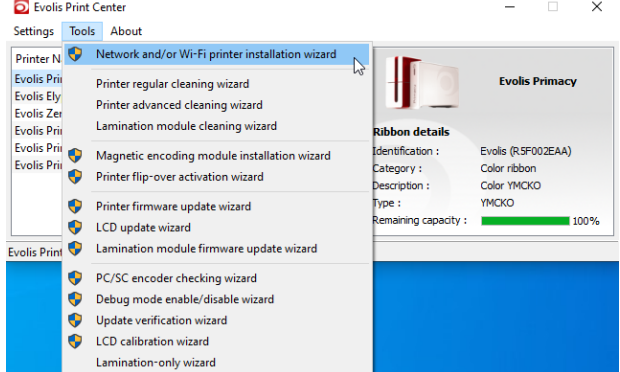
| in Standard/Supervision Mode | in Minimal Mode |
|---|---|
| <p>From the Print Center, click on Tools>Network and/or Wi-Fi printer installation wizard</p>  | <p>Click on Windows Start>Evolis Card Printer>Network and/or Wi-Fi printer installation wizard</p> |

Step 1: The wizard provides two ways to configure the Wi-Fi connection

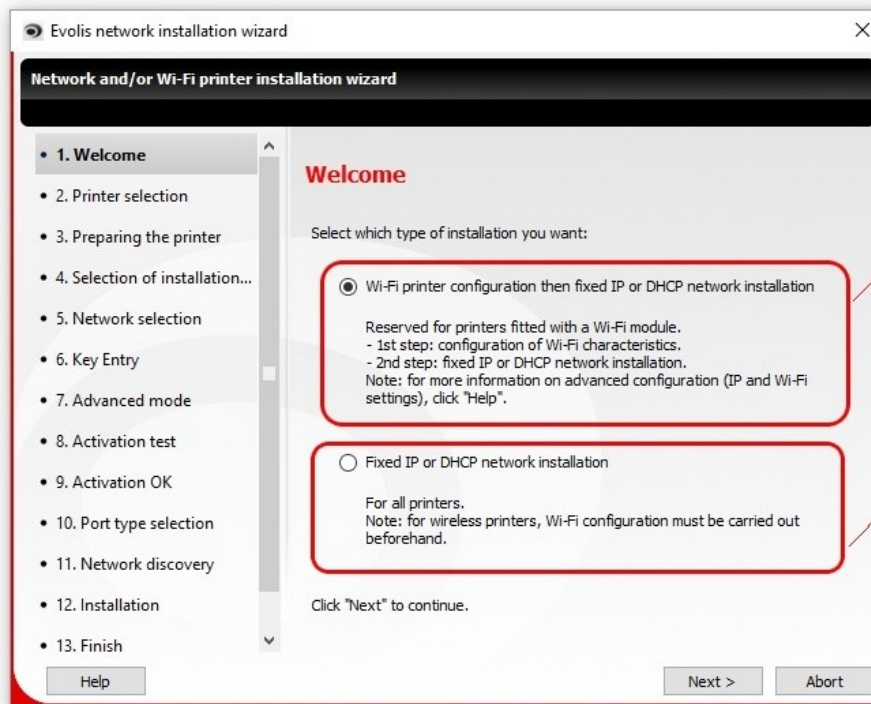

All steps are performed in the wizard

Step 1. Wi-Fi configuration in the Web Interface

Step 2. Printer configuration in the wizard

| | |
|--|---|
| <p>From Evolis Wizard</p> | <p>Performing All Configuration Steps with the Wizard ⁴⁴</p> |
| <p>From Web interface + Evolis Wizard</p> | <p>Using Web Interface and Wizard ⁵³</p> |

6.6.3.3.1. Using the Wizard for All Steps

Step 1: Launch the wizard.

In the **Welcome** window, select the first option and click on **Next**.



Make sure that:

- the USB cable is connected between your printer and your computer
- the printer is switched on

Step 2: In the list provided, select the printer and click on **Next**. Use the refresh button if the list of printers is not updated.

Step 3: The wizard provides two types of configuration:

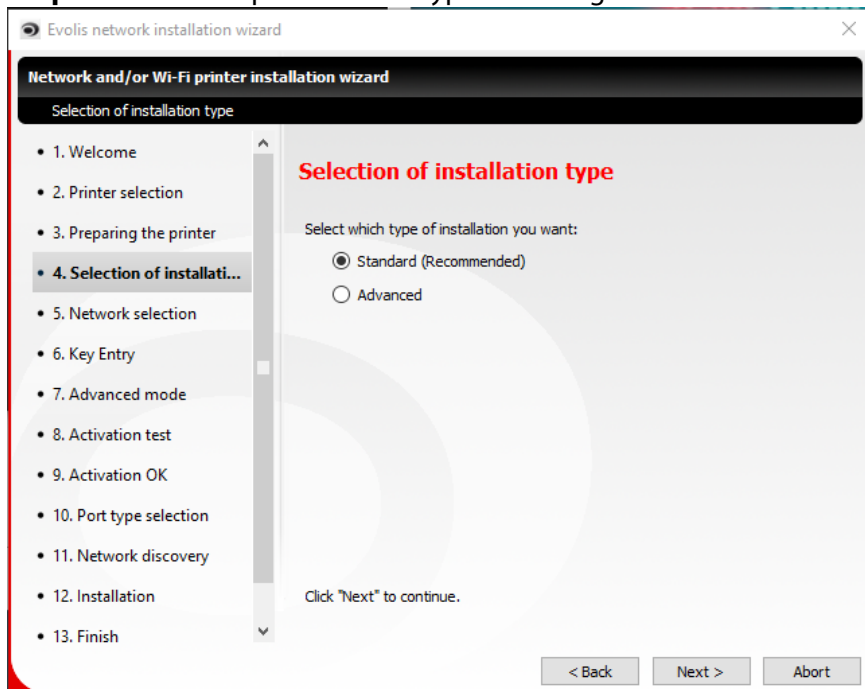

Standard: to set a Wi-Fi network with no security code

Advanced: to set a Wi-Fi network with a security code

Step 4: Select the network in the list displayed. If necessary, click on **Refresh** and wait for the networks to be displayed.

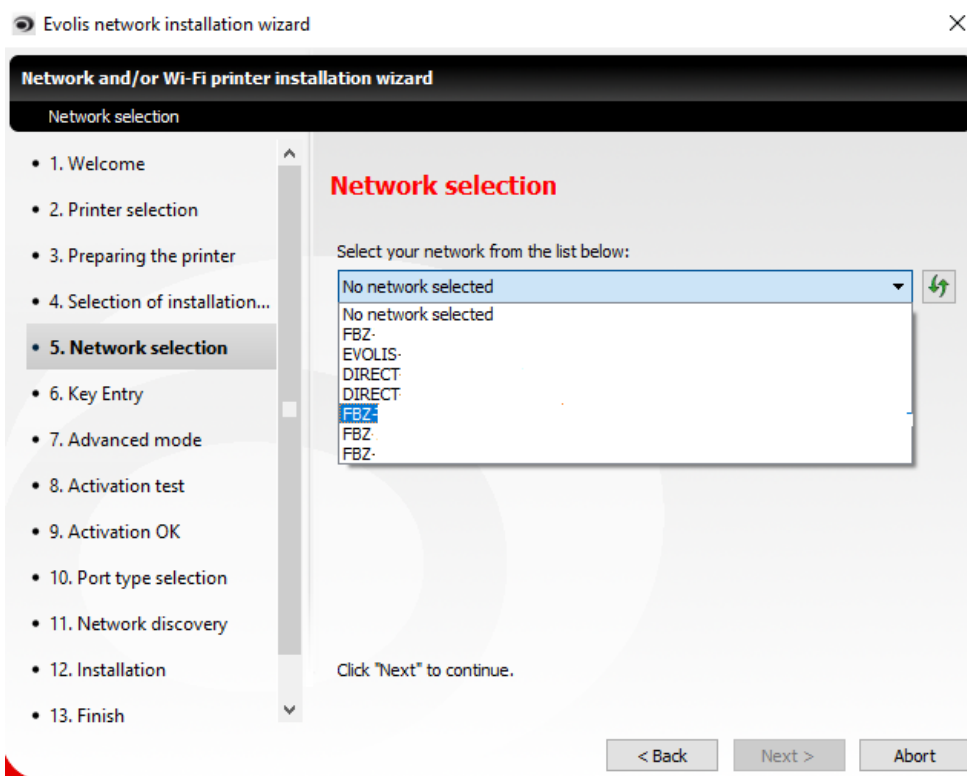

If the list is empty, go back to section [Wi-Fi Connection \(Primacy printer only\)](#)⁴² and follow the steps.

Step 5: Select the type of Wi-Fi access

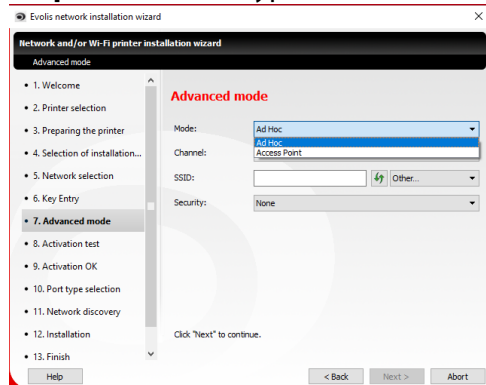

Ad Hoc: if your computers and devices have a Wi-Fi network card (wireless adapter or network interface controller) enabling to connect to a wireless network

Access Point: wireless "hub" that is connected to a wireless network and is linked to your computers and devices

Step 6: Set the SSID (name of the network) or select the network in the list named **Other...**

Step 7: Select the type of **Security** access and enter the code in the **Passphrase** field. Click **Next** to continue.

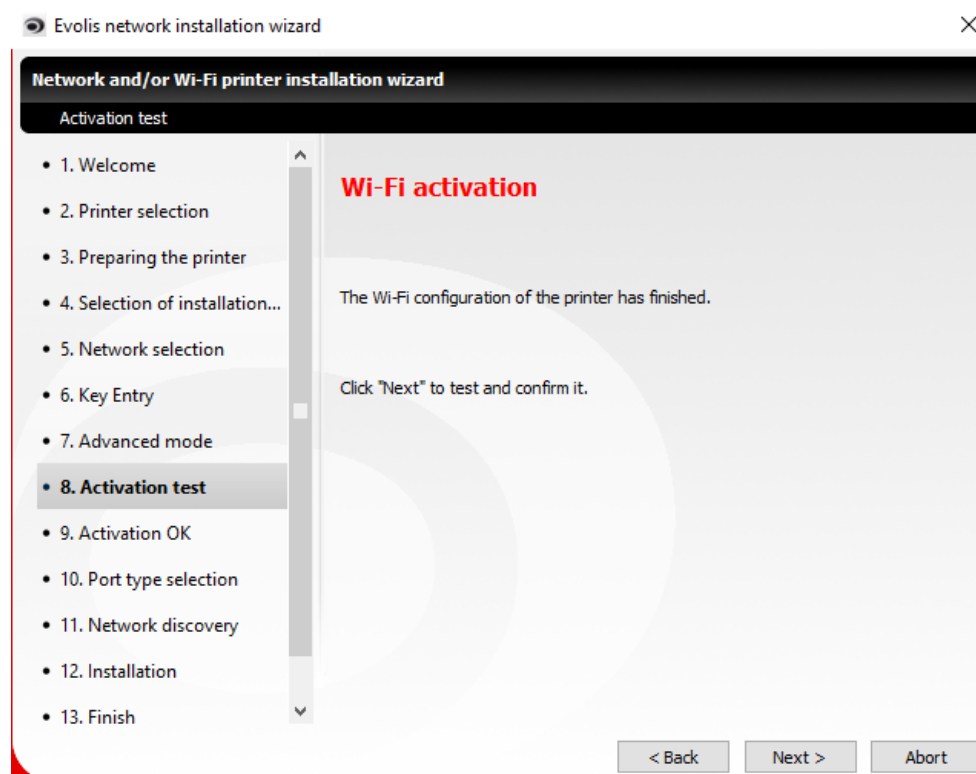
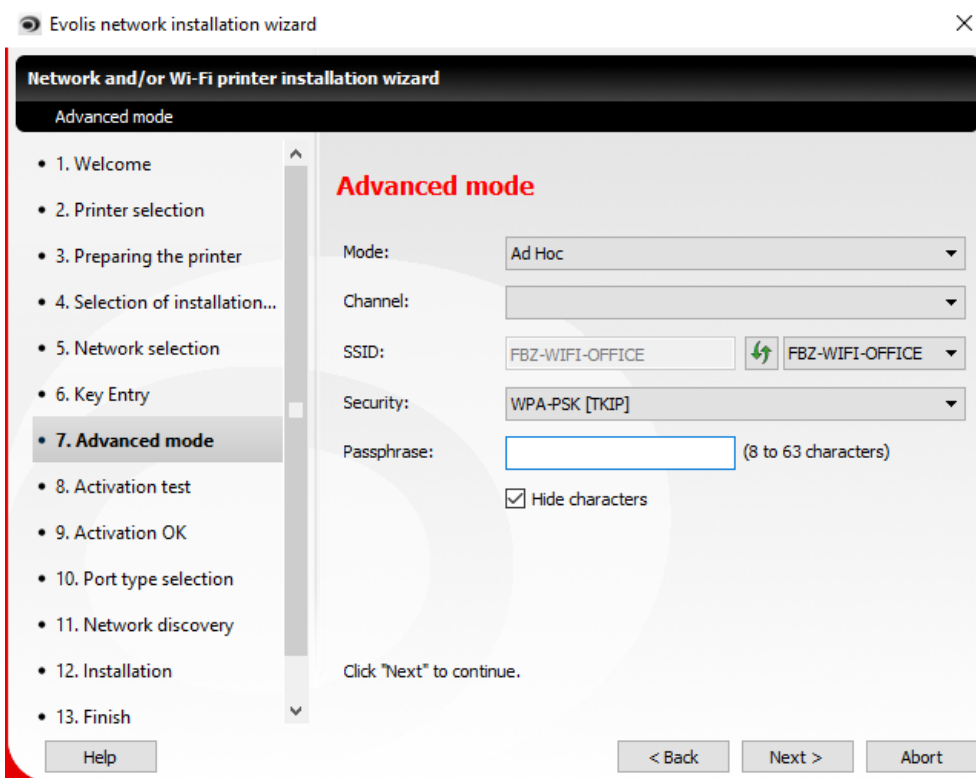

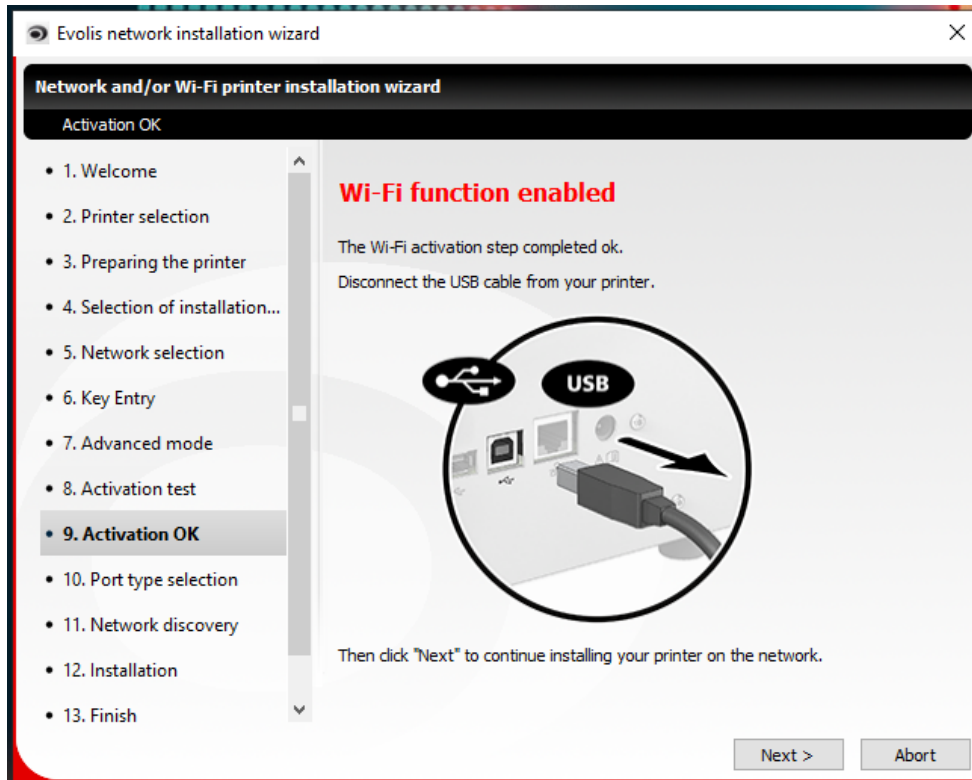

Make sure to disconnect the USB cable and click **Next**.

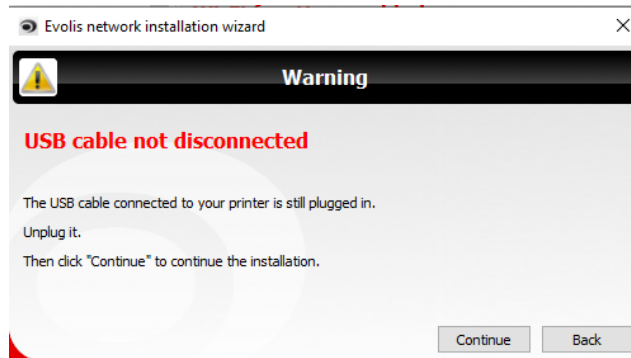

A message is displayed with the serial number of your printer:

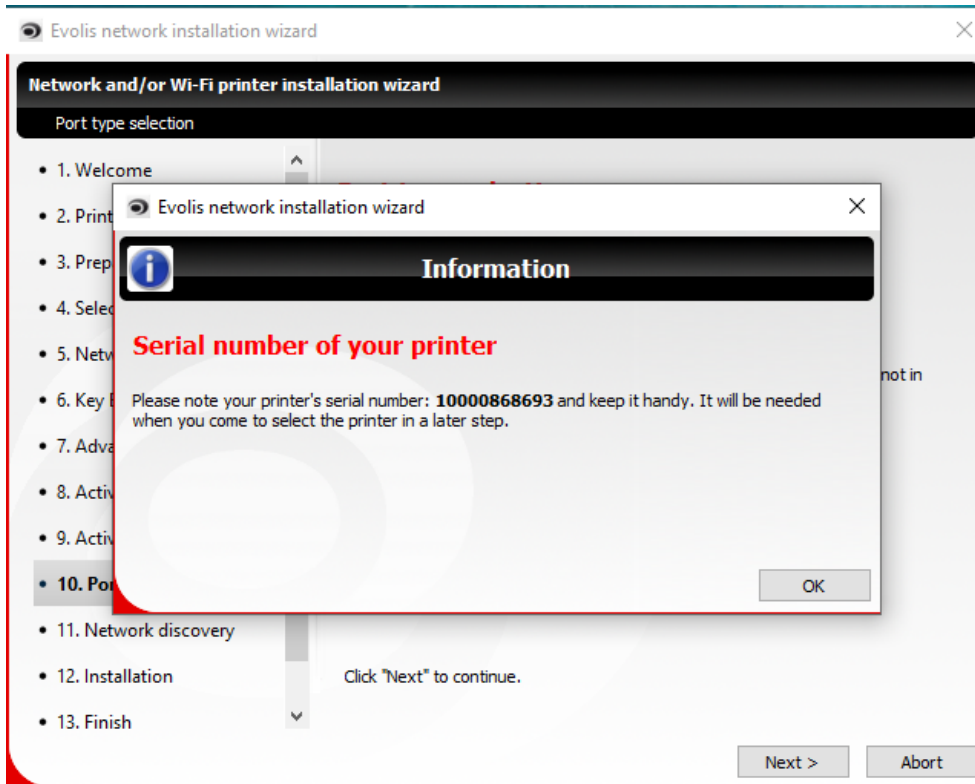

Step 8: Select the port, as planned and configured in section [Choosing and Checking the Type of Connection](#) 42.

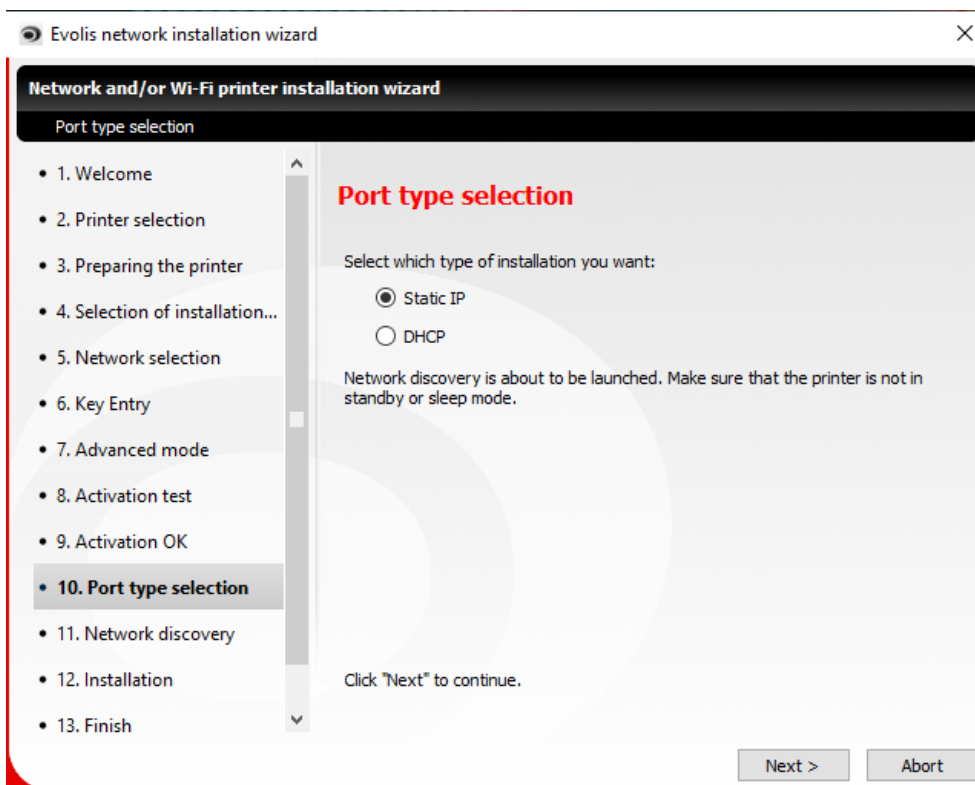

The printers that are detected are now listed in the window, with:

- their serial number (Printer S/N)
- their IP address (fixed IP or DHCP protocol, depending on the configuration explained in section [Choosing and Checking the Type of Connection](#)^[42])

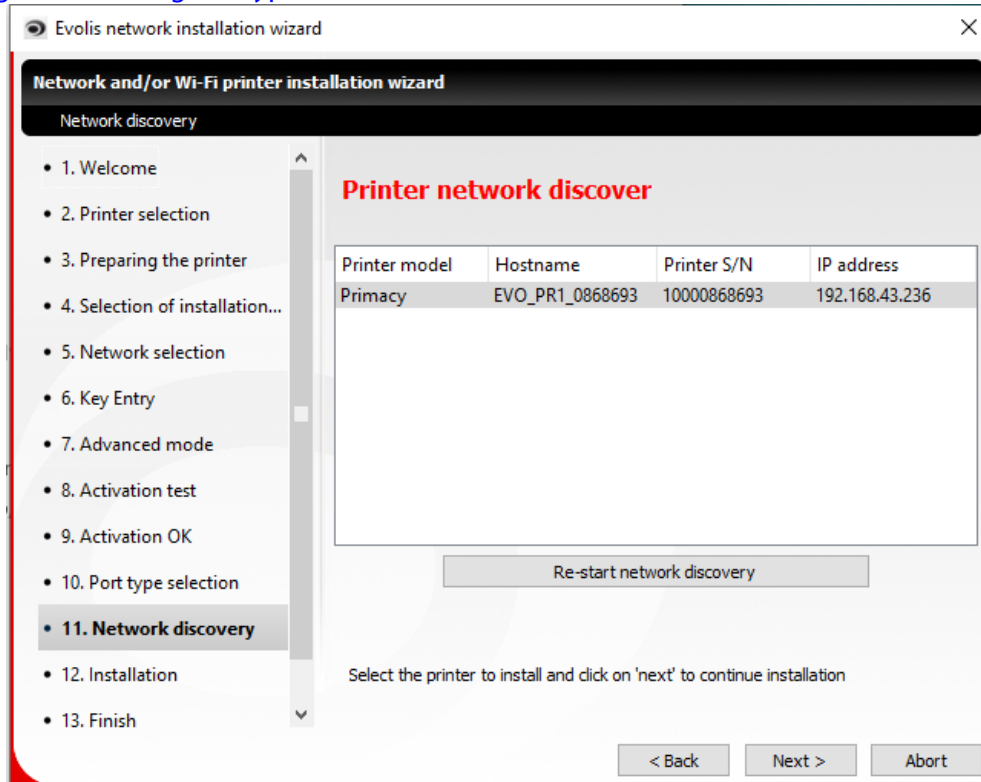

Step 9: Select the printer and click on **Next**.



The firewall may be blocking the flows of data between the computer and the printer. Make sure that the adequate ports are open (see section [Checklist Before Starting](#)^[29] and [Troubleshooting](#)^[153] for more details)

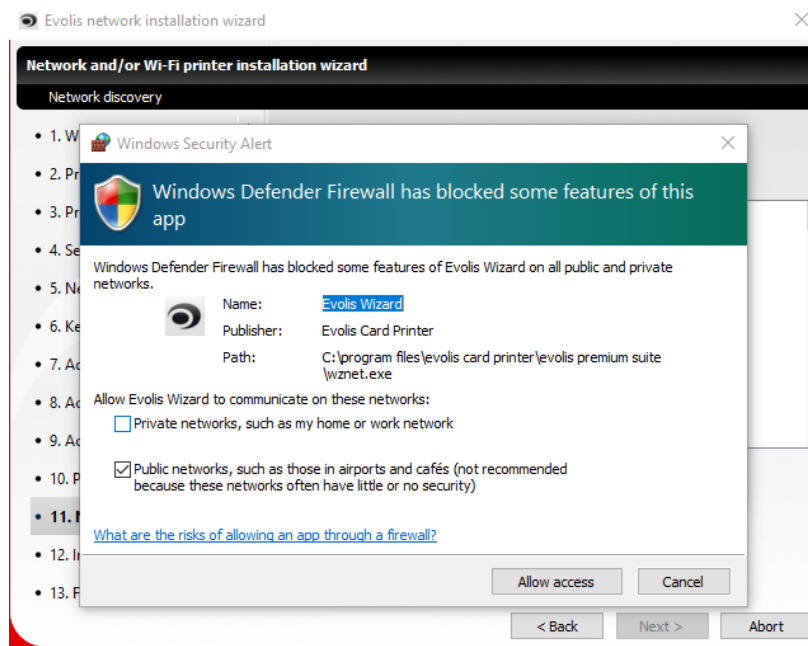

Step 10: In the **Installation** window that is displayed, change the port name and printer name.

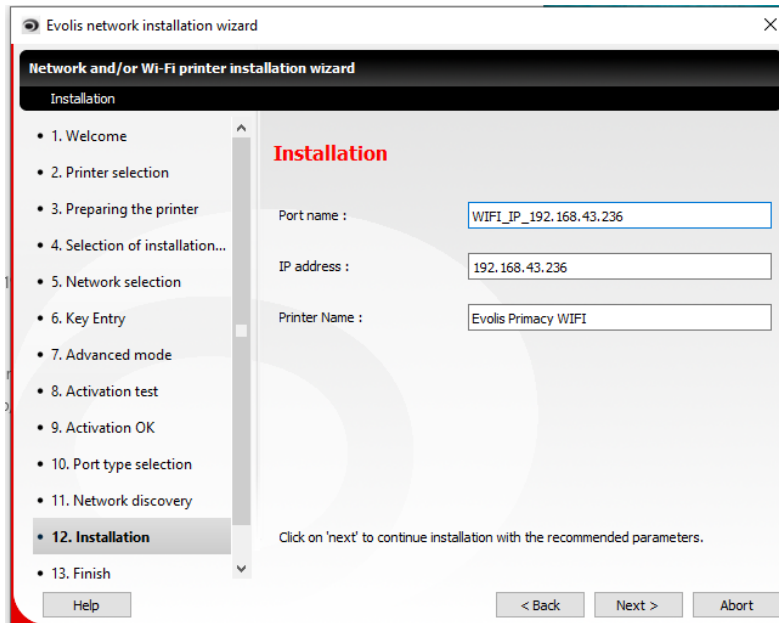

Static IP - Changing the name of the port and printer

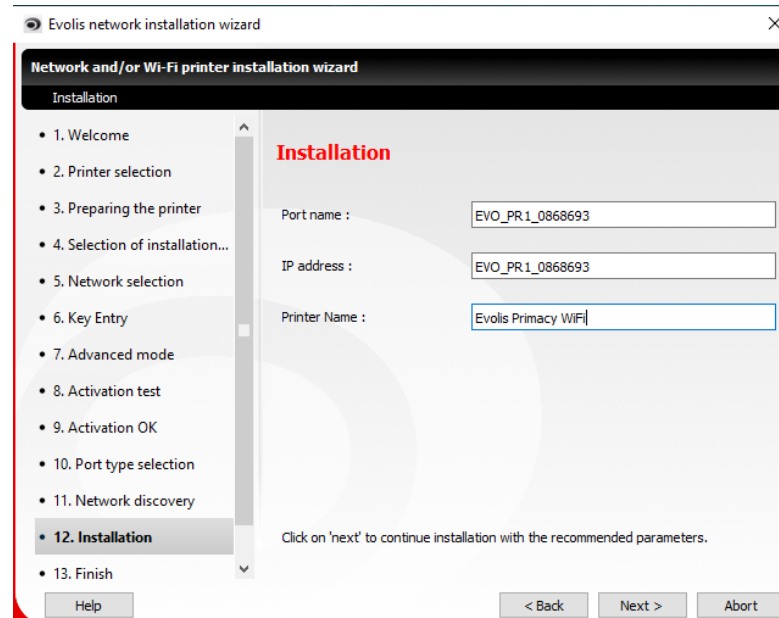

DHCP - Changing the name of the port and printer



It is strongly recommended to change the port name and printer name, so that a printer especially linked to the Wi-Fi network is available in the list of printers in **Control Panel > Devices and Printers**.

Step 11: Click on **Next**. The configuration of the printer detection is now finished.
 In Standard or Supervision modes only, the Print Center indicates that the printer is now **Ready**.

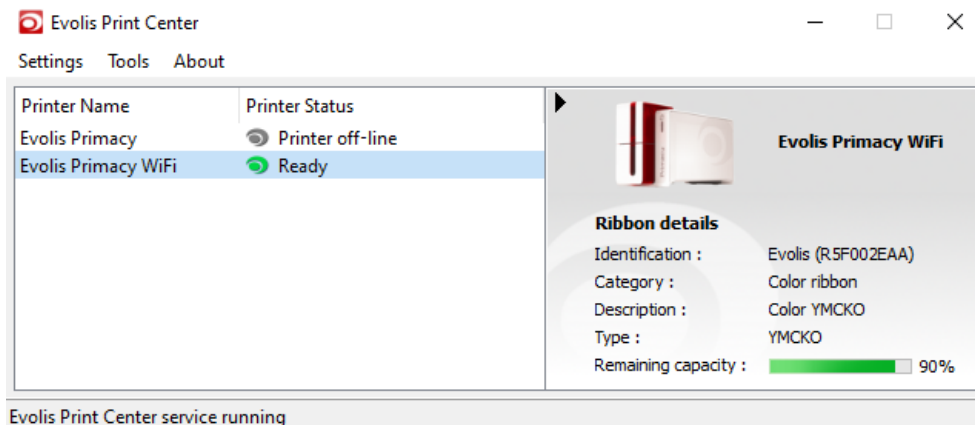

You can now print a card with the Wi-Fi printer that you just configured.

6.6.3.3.2. Using the Web Interface and the Wizard

Open a Web browser, type the **IP address** of the Primacy printer and type on **Enter**.

In **Wireless>Mode**, select:

- **Ad Hoc** to set a network with SSID configured in WSI0 (non secured/ no WEP available)
- or **Access Point** to set a network with a security key

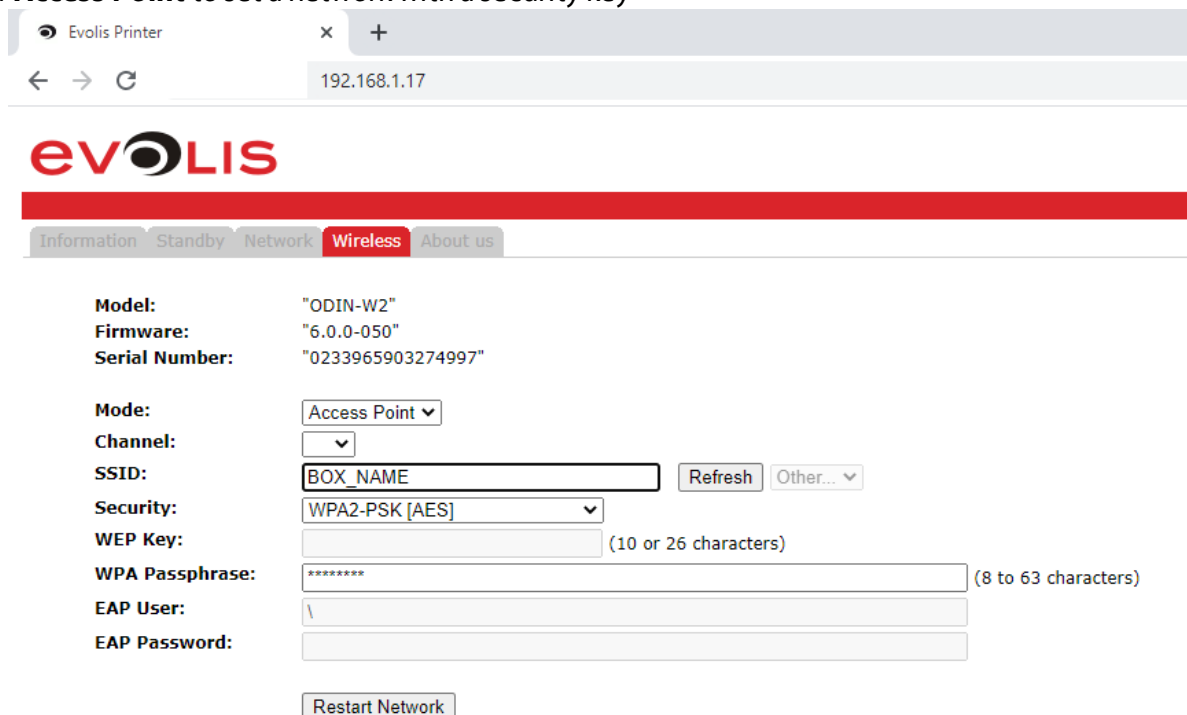

Once you have completed all parameters in the interface:

1. unplug the USB cable
2. start the Wi-Fi wizard. Follow its instructions, as explained from **Step 8** of section [Using the Wizard for All Steps](#)⁴⁴.

6.7 Upating both the EPS and Printer Firmware

The EPS provides a wizard to check and update both the driver suite as well as the firmware for your currently connected printer.

With this update, the most recent versions will be installed on your computer and in your printer.



This wizard only works with an Internet connection.

Step 1: Go to **Tools>Update verification wizard**

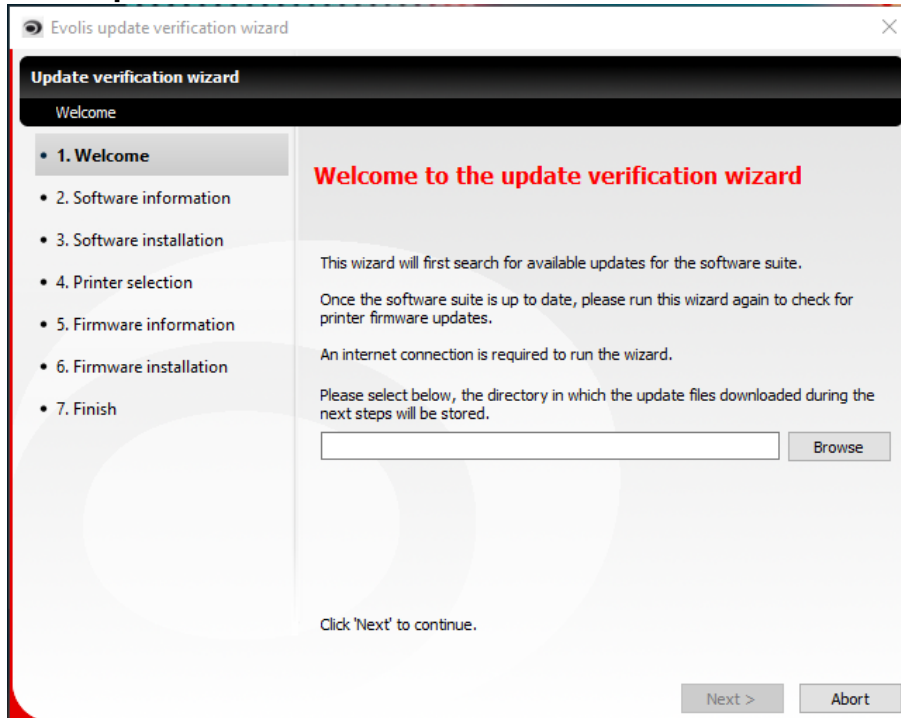

Step 2: Follow the wizard.

EPS version that is currently installed on your computer is checked, and updated if necessary.

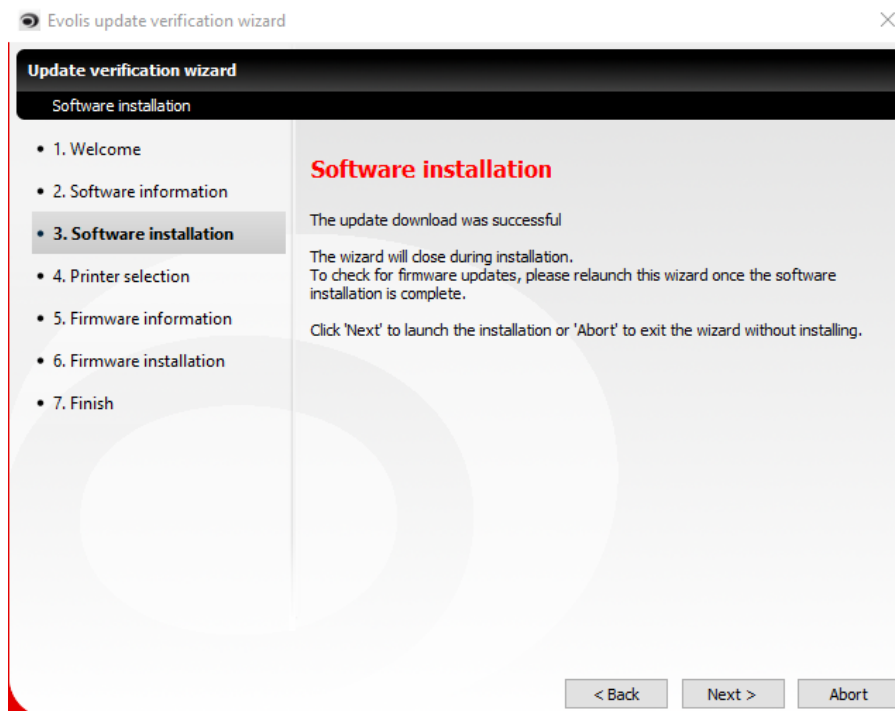
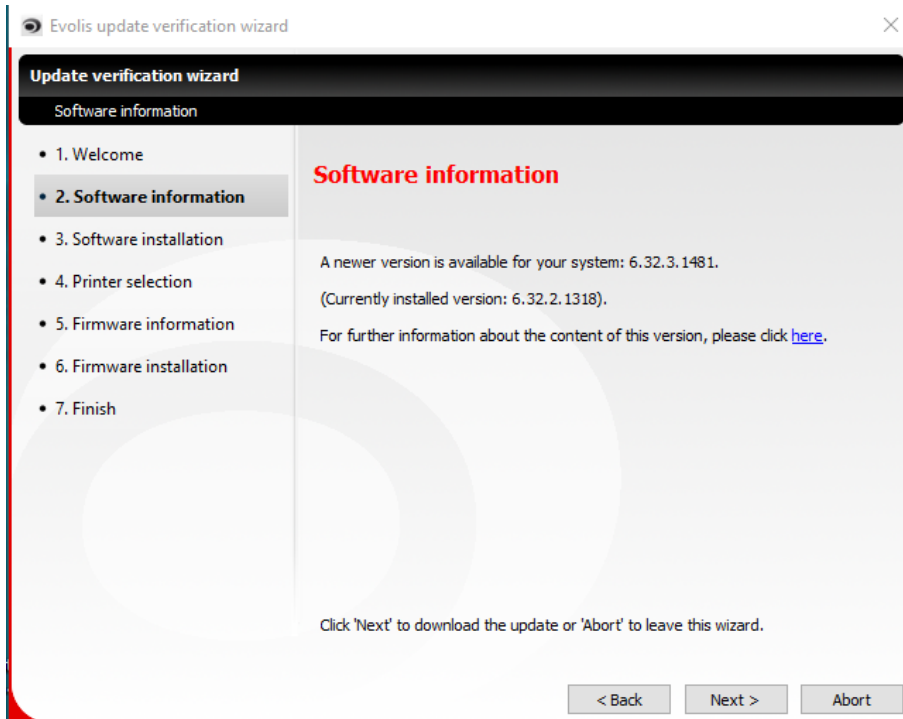

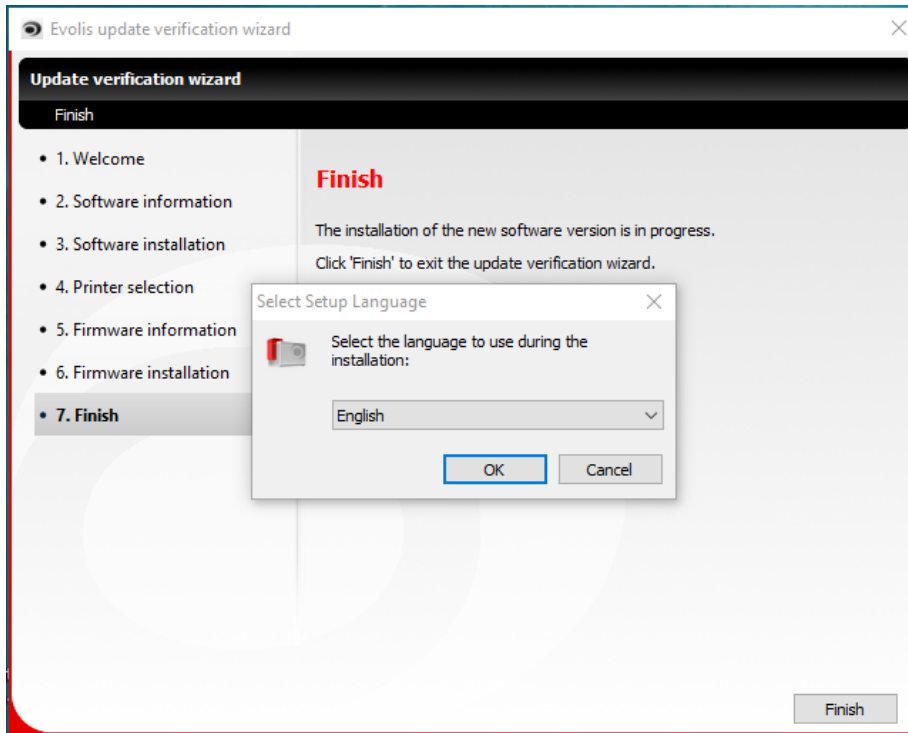

Step 3: Relaunch the wizard (**Tools>Update verification wizard**) to check the firmware version.

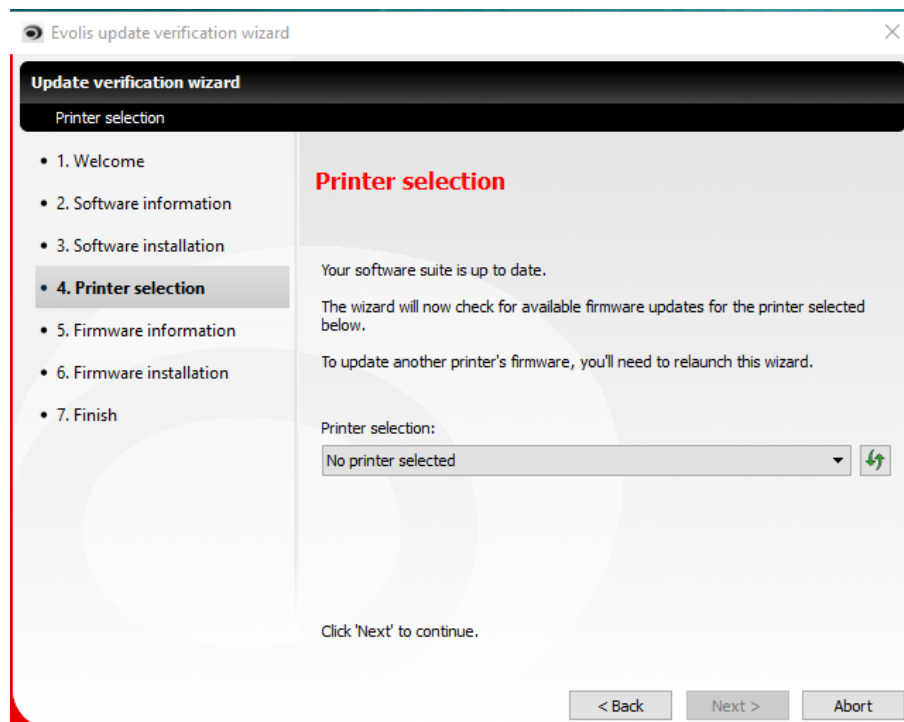

See section [Firmware Update](#)¹⁴⁸ for more details.

6.8 Uninstalling the EPS



Launching the EPS installation file will automatically replace the previous driver installed. In case you want to uninstall the current EPS version anyway, please follow the procedure described below.

Step 1: Go to **Windows Settings>Apps>Apps & features**.

Step 2: From the list of applications displayed, click on **Evolis Premium Suite>Uninstall**.

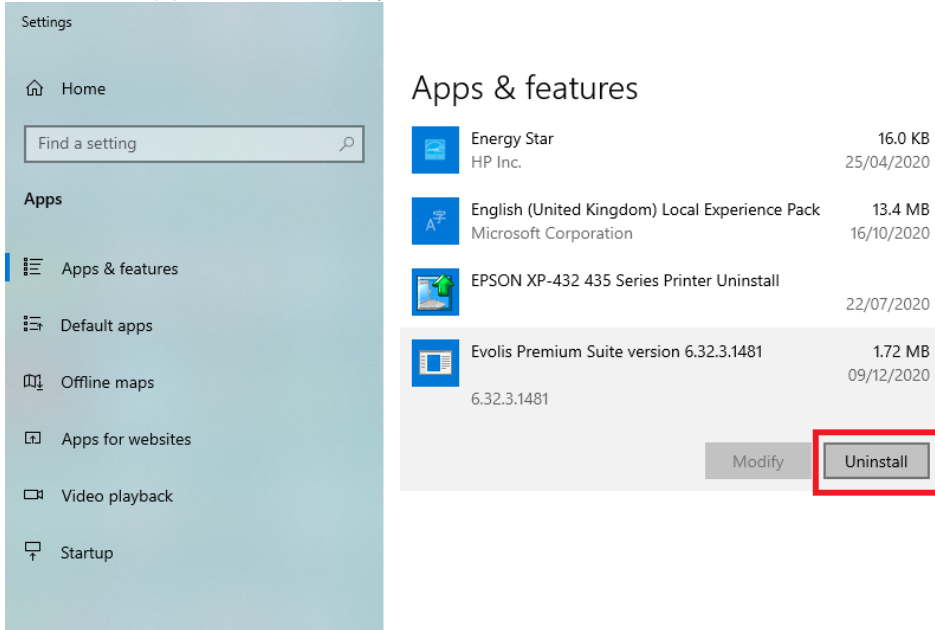

7. Accessing and Changing Printing Settings

7.1 Native Driver Printing Settings (all installation modes)

The OS native driver settings are called printing preferences or printer properties, depending on the access point of those settings.

They are available in all installation modes (Standard, Minimal or Supervision) but particularly useful in Minimal Mode.

Printing preferences contain less parameters than properties available in the **Evolis Printer Properties**.

However, they provide a single interface with the most often used settings.

Changing settings through the native driver is adequate in the following situations:

=> all settings that you need to customize printing jobs are in the native driver

=> you need to keep a stable and default configuration for general printing contexts

Please refer to [Changing Print Settings Through Native Driver: Use Cases](#)⁶⁰ for more context-driven details.



Native driver settings and Evolis Printer Properties are synchronized.

In other words, if you change the setting in one interface and click on **Apply**, the change is also made in the other interface.

7.1.1. Accessing Native Driver Printing Settings

There are two ways to access the settings.

Option #1: Your card designing application allows direct access to the driver settings

Click on **Print>Printer Properties** or **Print>Advanced Options**

Access in Word:

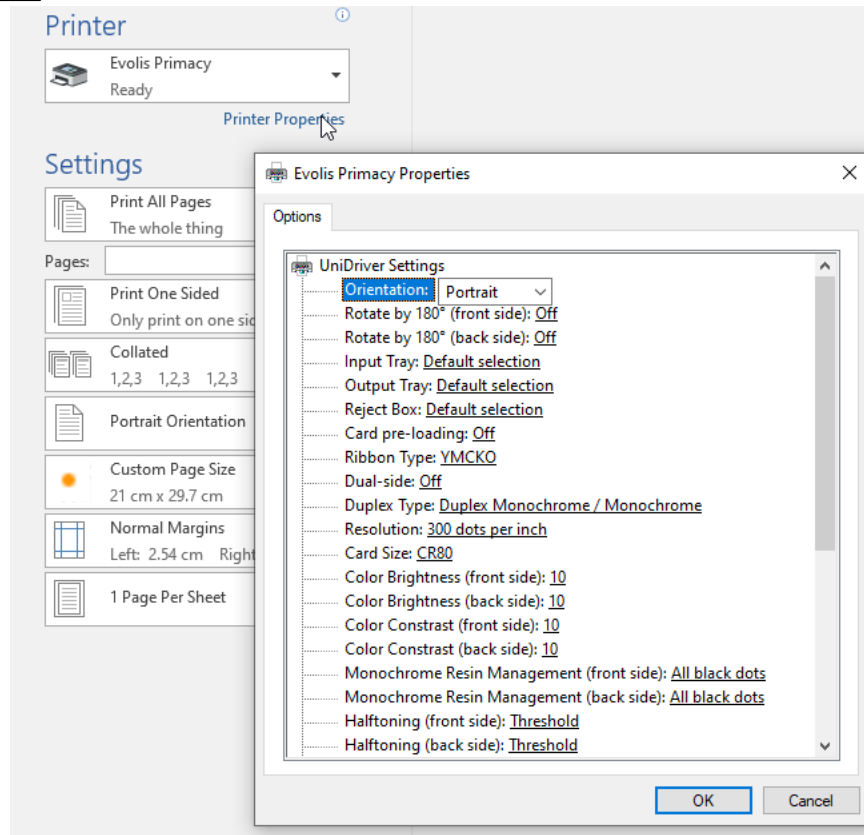

Access in Cardpresso:

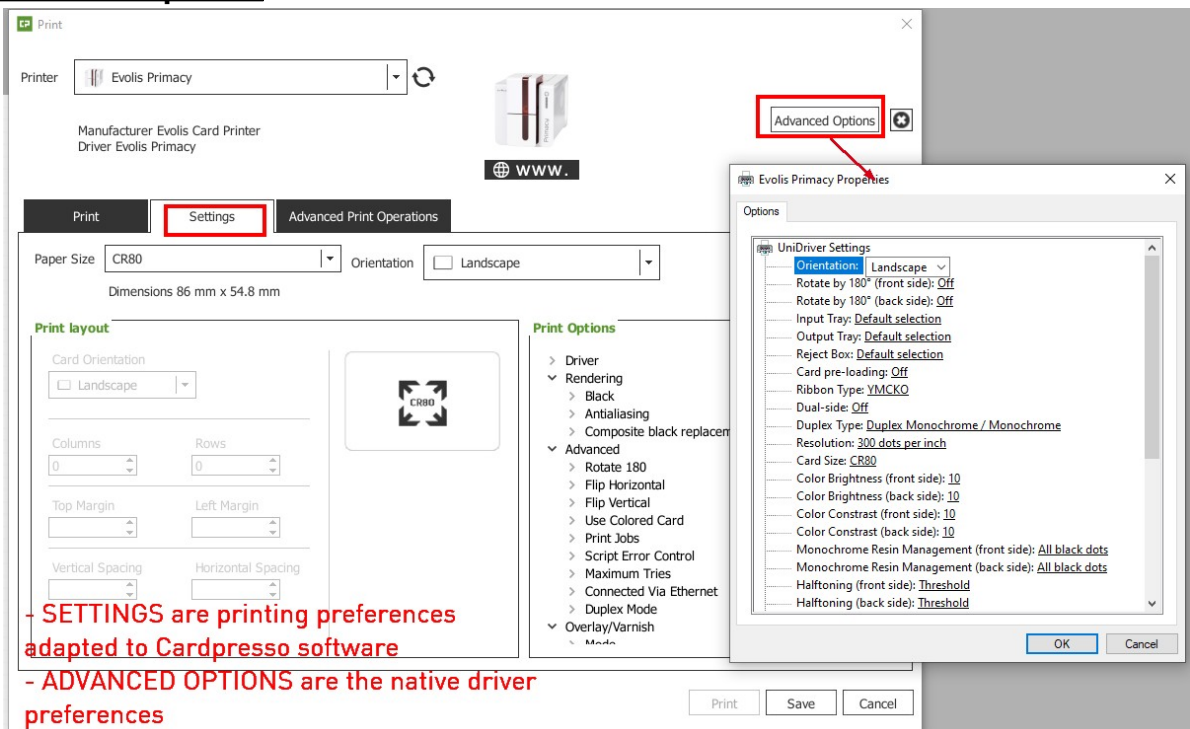

Option #2: The card designing software does not allow direct access to the driver settings

You can access the printing settings through the **Control Panel**.
The access is different according to the OS type and version.

Access on Windows 10

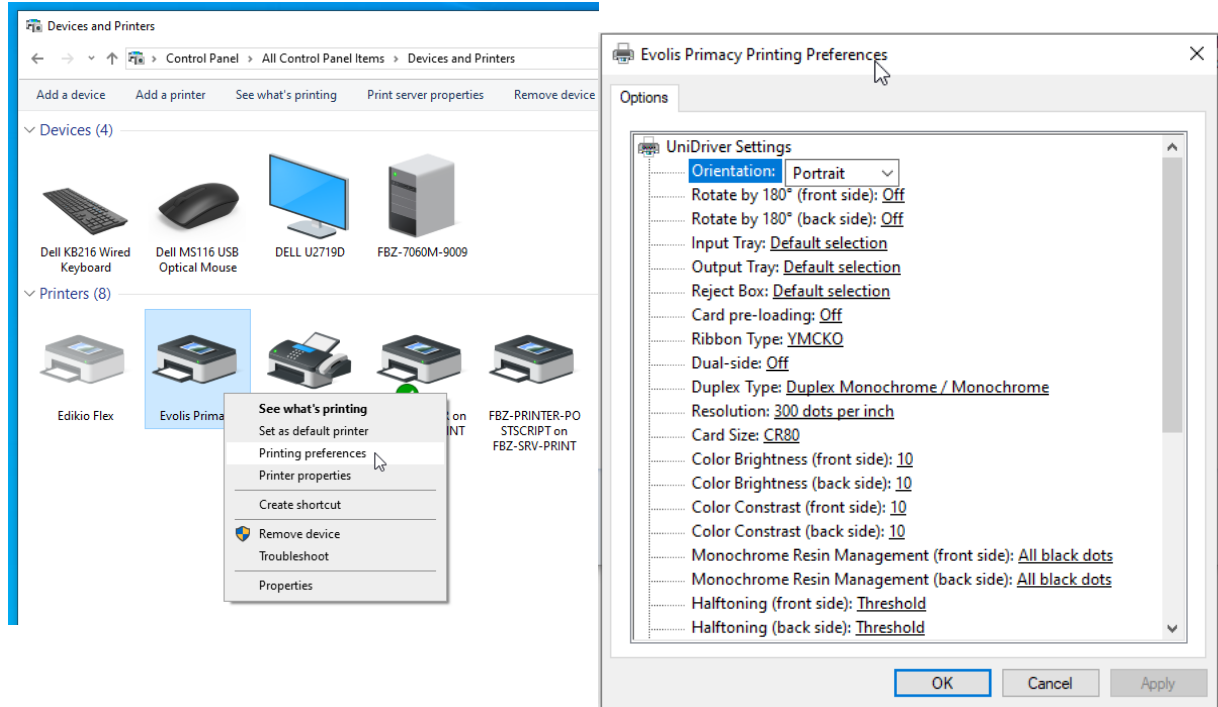

7.1.2. Changing Print Settings Through Native Driver: Use Cases

USE CASE #1: using a pre- configured custom bitmap

Step 1: In the Evolis Printer Properties (all modes) or in the Evolis Print Center (Standard/Supervision Mode), you have configured a bitmap file for no varnish on a magnetic stripe. You have been using this bitmap file together with the selection of "**custom bitmap**".

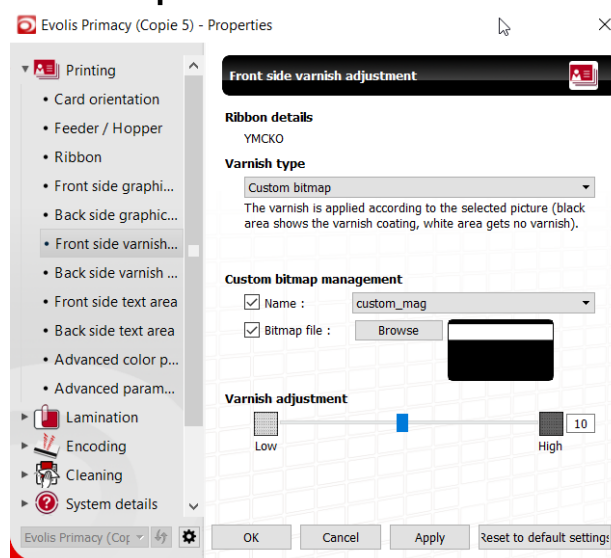

Step 2: You now decide to print a batch of cards that have a full varnish.

=>No need to go back to Evolis Printer Properties nor Evolis Print Center.
From the native driver, simply select the option "**full varnish**" of Varnish option and click on **Apply**.

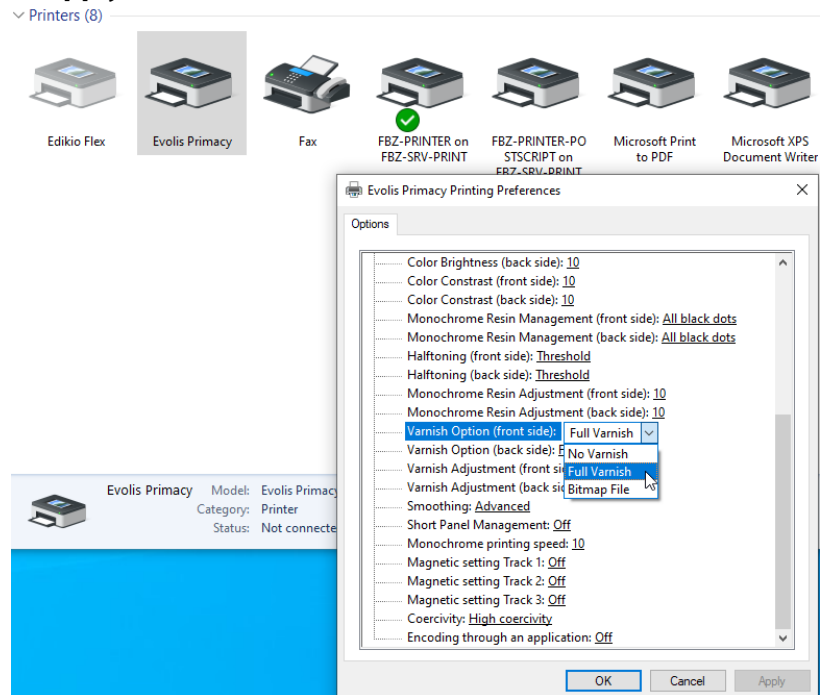

The option will be changed for your current printing job only.

Step 3: You want to go back to printing cards with a magnetic stripe and with the custom file that you used before.

=>No need to go back to Evolis Printer Properties nor Evolis Print Center.
From the native driver, simply select "**custom bitmap**" of the Varnish option and click on **Apply**.

The last file configured in **Step 1** will be used.

**USE CASE #2:
using a stable
settings
configuration**

Step 1: You are using Word application to print a picture with the Portrait orientation.
Go to **File>print** and select **Portrait**.

Step 2: You want to print the same picture, but directly from your desktop, and with the Landscape orientation.
=> Right-click on the picture that you want to print. In this case, the settings applied are the native driver ones. Orientation is set on **Landscape**.

The configuration set in the native driver is the one used by default when you do not print from an application that provides other printing settings.

7.2 Evolis Printer Properties (all installation modes)

Evolis Printer Properties are accessed through **Start Menu>Evolis Card Printer** folder of your computer, in all three modes (minimal, standard and supervision).

In Standard/Supervision modes, those properties are also accessed to from the Print Center. Please refer to section [Printer/Lamination Module Properties](#) to get all details on the features.

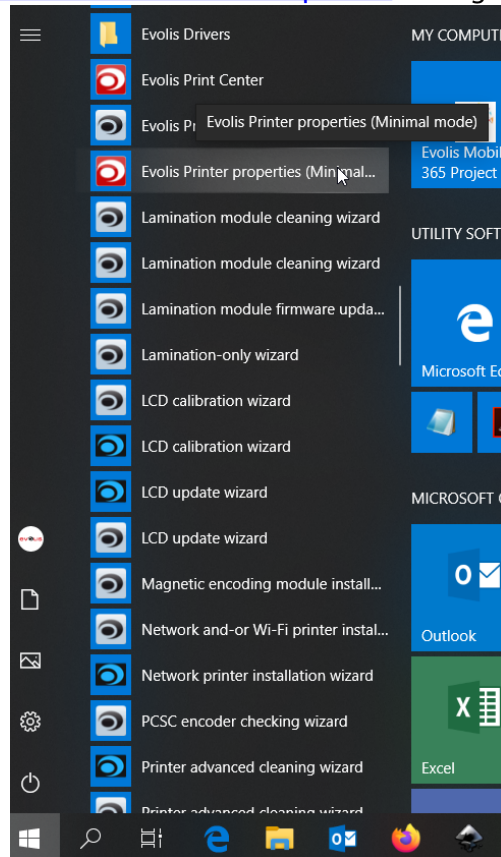

Mostly in Minimal Mode, using Evolis Printer Properties may be necessary to change specific printing settings that cannot be accessed through the native driver interface.

Changing printing settings from Evolis Printer Properties also offers a much better user experience (user-friendly interface and explanations) than from the native driver.

7.3 Using the Print Center (Standard and Supervision Modes)

As a reminder, the **Standard/Supervision modes** are only available on Windows®. It means that the Print Center is only available on Windows.

7.3.1. Description of Print Center Interface

The Print Center is organized as follows:

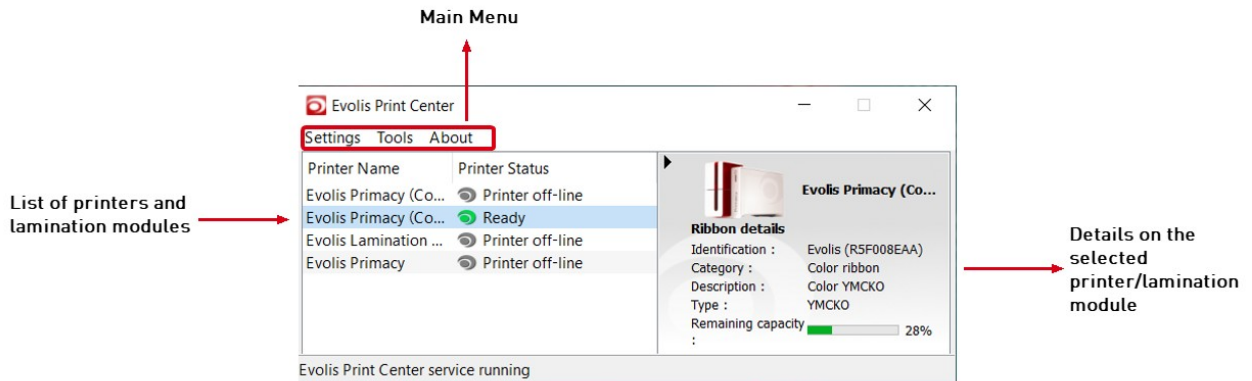

- **Status Icons:** In the Printer Status, the Print Center displays all useful statuses on the printer or lamination module.

For the meaning of status icons, please refer to section [Printer Manager: status and notifications](#) [64].

- To access the **Properties**, follow those steps:

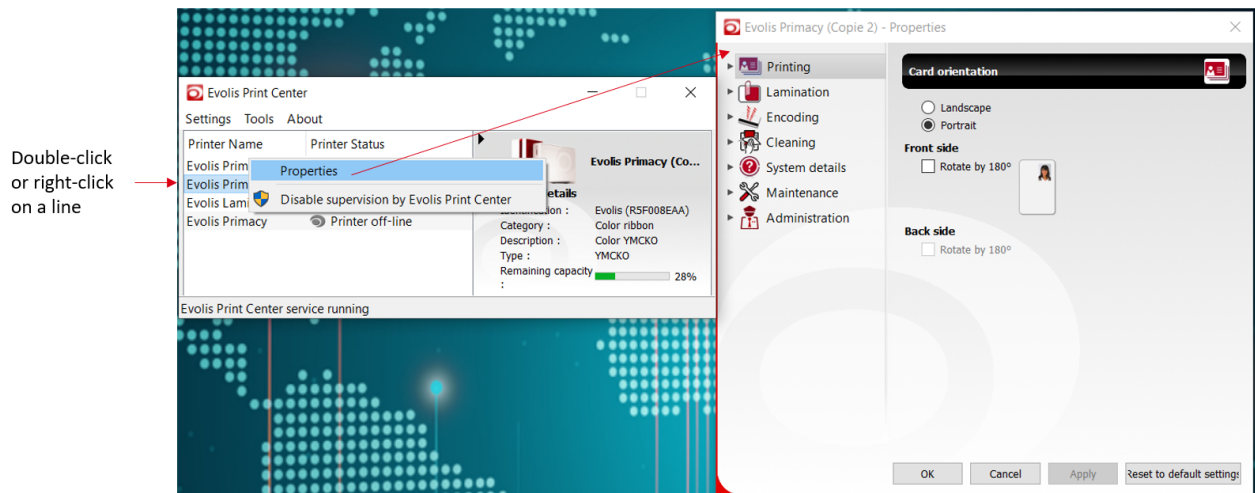

Please refer to section [Printer/Lamination Module Properties](#) [71] for more details.



A right-click on the printer name also offers the possibility to disable supervision by Evolis Print Center.

This feature is dedicated to expert users. Please contact the [Support](#) team for more information.

- **Settings, Tools** and **About** are explained in the [Main Menu](#) [66] section.

7.3.2. Printer Manager

The Printer Manager displays pop-up notifications whenever the user launches a printing job while the printer is not in operable condition.



The notifications are usually displayed as pop-up messages on the bottom right of your desktop.

If the printer is equipped with a LCD device, the messages are also displayed on the LCD screen.

The meaning of the different status colors is as follows:







| Icon color | Meaning |
|------------|--|
| | The printer/lamination module is ready |
| | The printer/lamination module is not connected (power supply or USB cable is disconnected) |
| | An action is required to enable printing/lamination The job will automatically resume after the action is implemented |
| | An error has occurred in the printer/lamination module and some action is required |

Examples of the different notifications are listed below.

You can either click on:

- the interrogation point button to get information
- the cross button to cancel the action
- the refresh button to restart the printing job

| Printer Status Category | Pop-up notification examples |
|-------------------------|------------------------------|
| INFORMATION | |

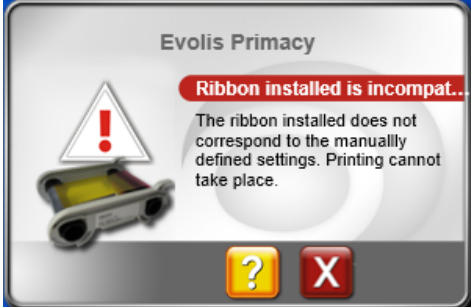
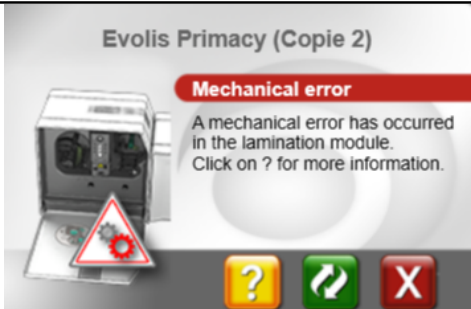
| Printer Status Category | Pop-up notification examples |
|-------------------------|---|
| <p>WARNING</p> | <div data-bbox="545 309 970 595"> <p>Evolis Zenius</p> <p>Card feed problem</p> <p>Please check cards, position in the card feeder and gauge adjustment.</p>  </div> <div data-bbox="979 309 1404 595"> <p>Evolis Zenius</p> <p>Card feed problem</p> <p>Please check cards, position in the card feeder and gauge adjustment.</p>  </div> <div data-bbox="545 622 970 909"> <p>Evolis Zenius</p> <p>No ribbon</p> <p>Replace the ribbon.</p>  </div> <div data-bbox="979 622 1404 909"> <p>Evolis Zenius</p> <p>Printer in Sleep mode</p> <p>Press printer's control button.</p>  </div> <div data-bbox="715 945 1232 1285"> <p>Evolis Primacy</p> <p>Ribbon not identified</p> <p>Ribbon identification impossible. Please proceed with Manual settings.</p>  </div> <div data-bbox="501 1294 963 1599"> <p>Evolis Elypso</p> <p>Ribbon problem</p> <p>The ribbon is cut or stuck to the card. Click on ? for more details.</p>  </div> <div data-bbox="973 1294 1445 1599"> <p>Evolis Primacy</p> <p>Ribbon installed is incompat...</p> <p>The ribbon installed does not correspond to the manually defined settings. Printing cannot take place.</p>  </div> |
| <p>ERROR</p> | <div data-bbox="737 1630 1209 1937"> <p>Evolis Primacy (Copie 2)</p> <p>Mechanical error</p> <p>A mechanical error has occurred in the lamination module. Click on ? for more information.</p>  </div> |

7.3.3. Main Menu

The Main Menu is displayed at the top of the Print Center.

It includes the following tabs: **Settings, Tools, About.**

7.3.3.1. Settings

| Language | Administration | Close |
|---|--|-------------------------|
| Change the language of the interface (13 are available) | To stop Evolis Print Center Service, see section Disabling Supervision by the Print Center | Closes the Print Center |

7.3.3.2. Tools

This menu provides all wizards that will help you performing the most complicated tasks.

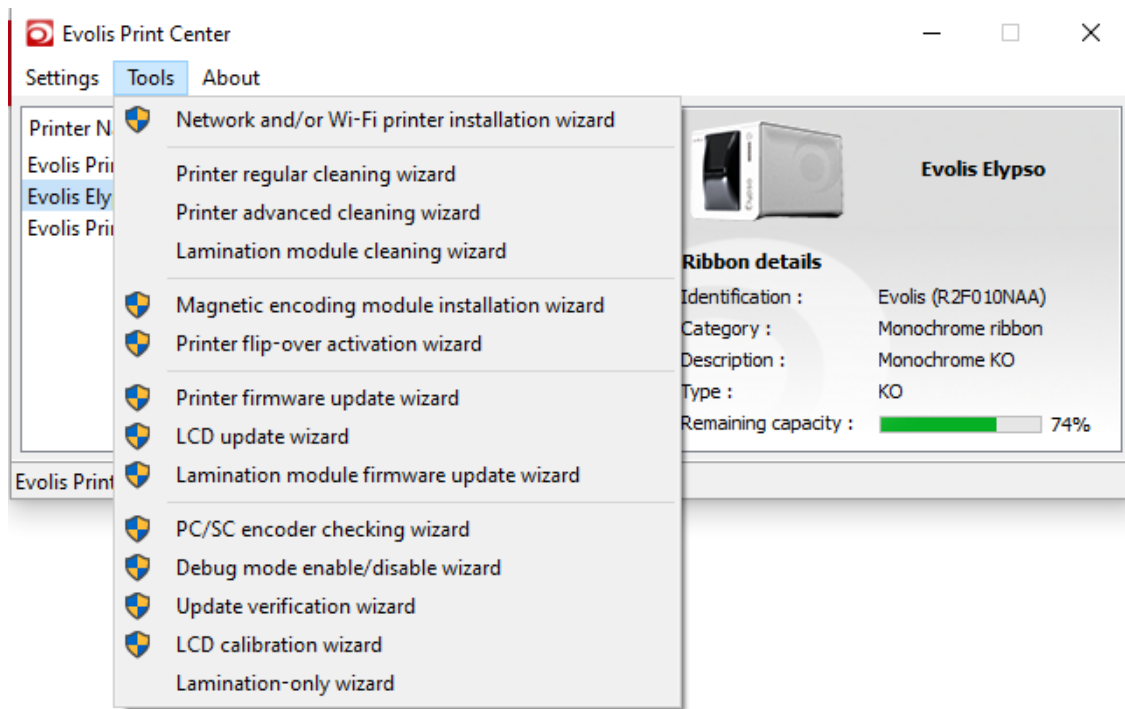

| Type of wizard | Corresponding section |
|--|--|
| Network and/or Wi-Fi printer installation wizard | Configuration of the Connection ²⁸ and its sub-sections |
| Printer regular cleaning wizard | Proceed With Regular Cleaning ¹³⁸ |
| Printer advanced cleaning wizard | Proceed With Advanced Cleaning ¹⁴⁰ |
| Lamination module cleaning wizard | Performing the Cleaning Task for Lamination ¹¹⁷ |
| Magnetic encoding module installation wizard | Checking the Installation of the Magnetic Encoder ¹²⁵ |
| Printer flip-over activation wizard | Flip-Over Activation Wizard ⁶⁸ |
| Printer firmware update wizard | Firmware Update ¹⁴⁸ |

| Type of wizard | Corresponding section |
|--|---|
| LCD update wizard | LCD Updates ⁶⁷ |
| Lamination module firmware update wizard | Updating the Lamination Firmware ¹¹⁵ |
| PC/SC encoder checking wizard | Checking the Installation of the PC/SC Encoder ¹³⁶ |
| Debug mode enable/disable wizard | Please contact the Support team for more details. |
| Update verification wizard | Upating both the EPS and Printer Firmware ⁵⁴ |
| LCD calibration wizard | LCD Updates ⁶⁷ |
| Lamination-only wizard | Lamination Tools ¹²⁰ |

7.3.3.2.1. LCD Updates



Two wizards help you updating the LCD on Primacy printer.

1. LCD calibration wizard

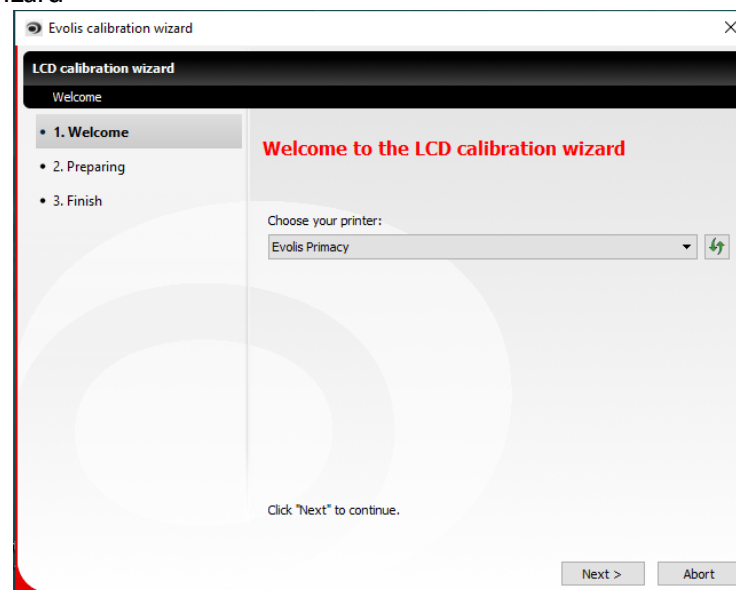

2. LCD update wizard

All useful files can be downloaded on the [website](#).

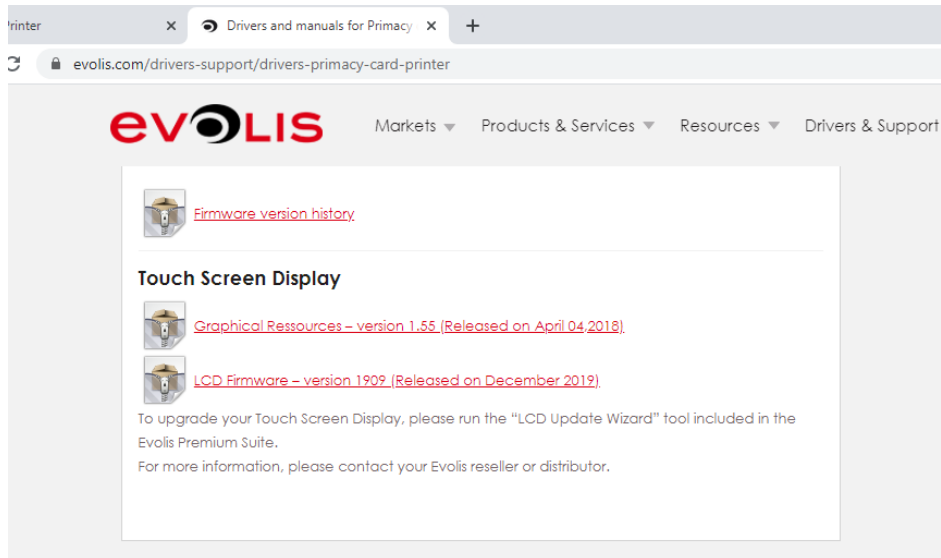

All details concerning the two updates are available in the [Color Touchscreen User Guide](#)

7.3.3.2.2. Flip-Over Activation Wizard

This wizard helps you activating the flip-over module in case it is not yet activated on your printer (for Primacy, Elypso printers).

The flip-over module enables you to print automatically on both sides of the card.

Before starting the wizard, retrieve the activation key that was shipped to you with the flip-over module.

Then follow the wizard instructions:

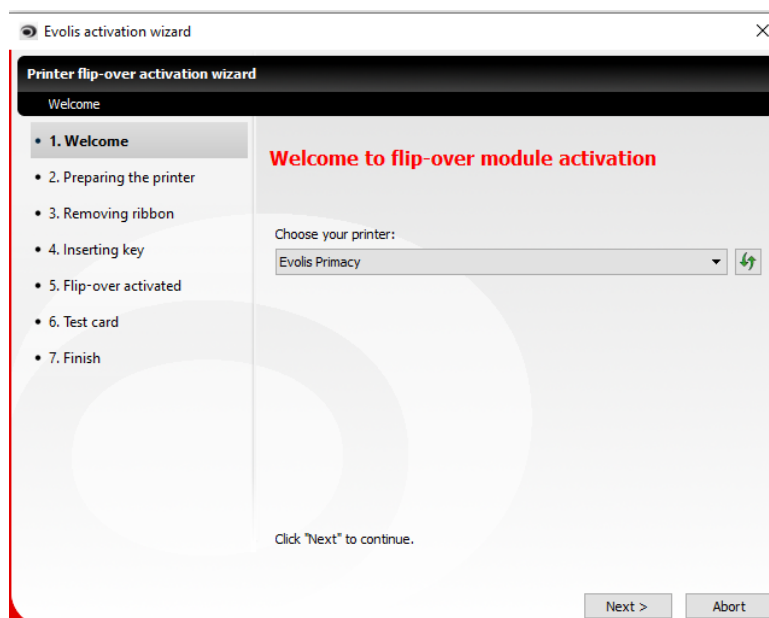

Evolis PrimacyNew - Properties

Evolis activation wizard

Printer flip-over activation wizard

Removing ribbon

- 1. Welcome
- 2. Preparing the printer
- 3. Removing ribbon**
- 4. Inserting key
- 5. Flip-over activated
- 6. Test card
- 7. Finish

Ribbon removal

Open the printer cover then remove the ribbon cassette, and keep the cover open.

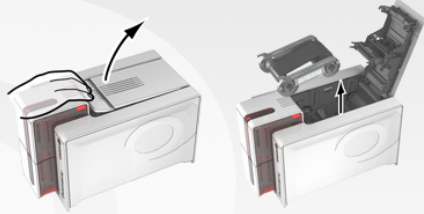

< Back Next > Abort

Evolis activation wizard

Printer flip-over activation wizard

Inserting key

- 1. Welcome
- 2. Preparing the printer
- 3. Removing ribbon
- 4. Inserting key**
- 5. Flip-over activated
- 6. Test card
- 7. Finish

Inserting the key

Remove the key from its packaging and insert it in the appropriate slot.



Close the printer cover to launch activation. This operation will require 10-15 seconds.



Help < Back Next > Abort

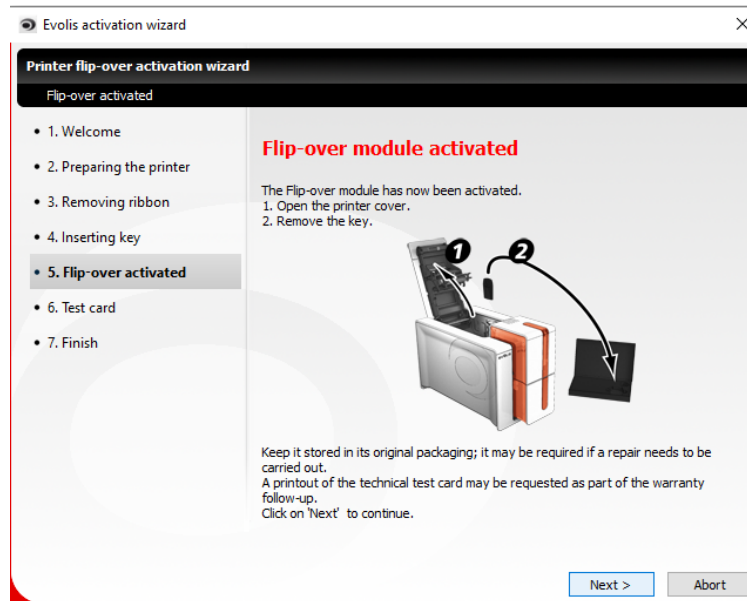

For more details, refer to the User Guide or watch the how-to videos (How to activate the flip-over module? for [Primacy](#) and [Elypso](#))



On Primacy printers equipped with a LCD , make sure that printer firmware, LCD firmware and graphical resources are up to date:

- printer firmware of minimal release 1701
- LCD display of minimal release 1637
- graphical resources of minimal release 1.42

If you have lost the key activation because of the requirements above were not met, please contact the [Support](#) team.

7.3.3.3. About

This window provides:

- the driver version
- the link to www.evolis.com website

7.3.4. Printer/Lamination Module Properties

Printing and lamination processes are not performed in the same hardware modules, but both are managed by Evolis Premium Suite



Watch this video to understand better the encoding and printing processes of an Evolis printer: [How does a plastic card printer work?](#)

Various softwares may be used to create a design and patterns on the card that you want to print:

- Evolis © applications: Cardpresso
- Microsoft® applications: Word, Paint, Notepad, Gimp, etc.
- Adobe® applications



As a reminder, whenever you change a setting in Evolis properties, make sure to click on **Apply** and **OK**.

7.3.4.1. Printing

7.3.4.1.1. Card Orientation

Use this feature to change the orientation of your design on the card.

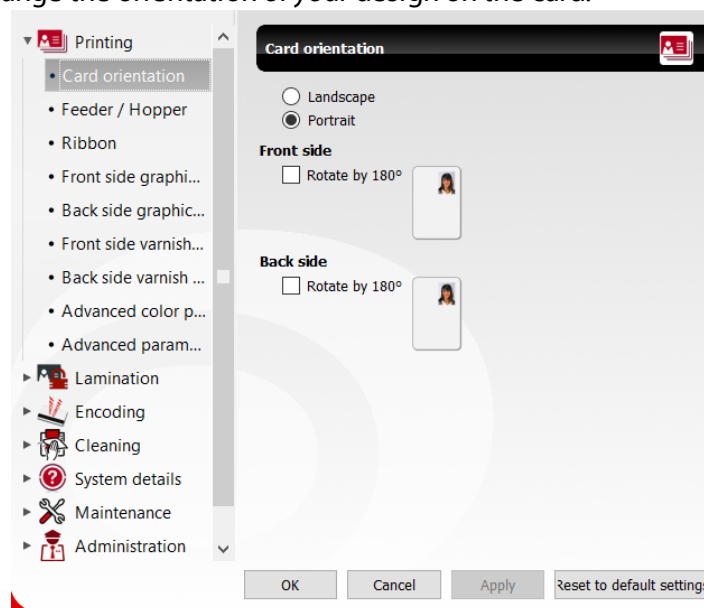

Step 1: Keep portrait orientation if your design is oriented vertically and tick landscape orientation if your design is oriented horizontally.

Step 2: Rotate each side (front and/or back) by 180°: this is especially useful when your design is made of a dark color first and then a lighter color.

In this case, the darker color may bleed onto the light color.

It is also useful when printing with a half-panel ribbon (see section [Short Panel Management](#))

**USE CASE #1:
dark and light
colors**

A card contains two colors: red (dark color) and yellow (light color).

Printing result when the rotation was not modified by 180°:
=> the red color has bled on the yellow color, because the first color printed was the darker one

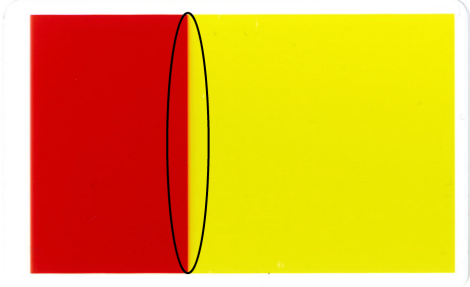

Printing result when the rotation was modified by 180°:
=> no color bleeding issue, as the first color printed was the lighter one (grey color)
The line between colors is frank, compared to the first image:

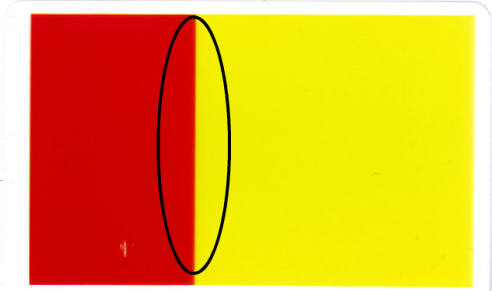

**USE CASE #2:
printing dual-
sided cards
with a simplex
printer
(back-side
rotation)**

To print a dual-sided card on a printer that does not have the duplex module activated, proceed as follows:



7.3.4.1.2. Feeder/Hopper



It is recommended to use default settings, as they are adapted to the current printer. However, for specific printers, changing default settings may be necessary. Details will be provided in the **Use Case** sections.

7.3.4.1.2.1. Card Insertion

The insertion of the card in the printer is the first step of the printing process.

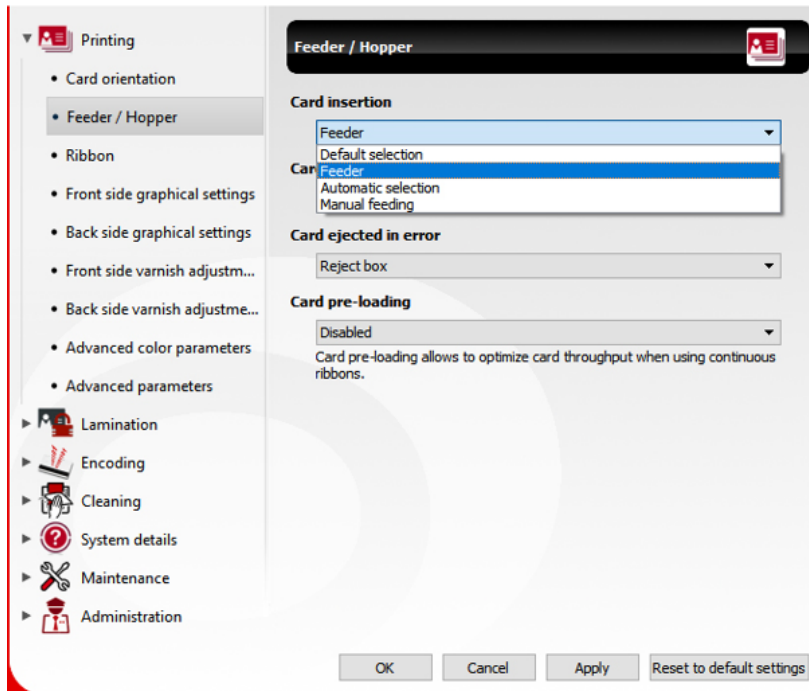

Default selection:

recommended setting according to the type of current printer
For example, on a Zenius printer, the default option is the card insertion through the feeder, even if manual insertion is also a possibility ("**Manual feeding**" option)

Feeder: the card is fed using the classic feeder

Automatic selection: the card is fed by using either the classic feeder or the manual feeder (as long as your printer has a manual feeder), depending on the presence of the card on any of the feeders

Manual feeding: the card is hand-fed through the manual feeder

| | |
|--|--|
| USE CASE: using a Zenius printer | This printer has two card-feeding options: <ul style="list-style-type: none">- 50-cards input hopper- manual feeder In case you only need to print one card or two cards at a time, you should select Manual feeding . |
|--|--|

7.3.4.1.2.2. Card Exit

The exit of the card is performed at the end of a successful printing process.

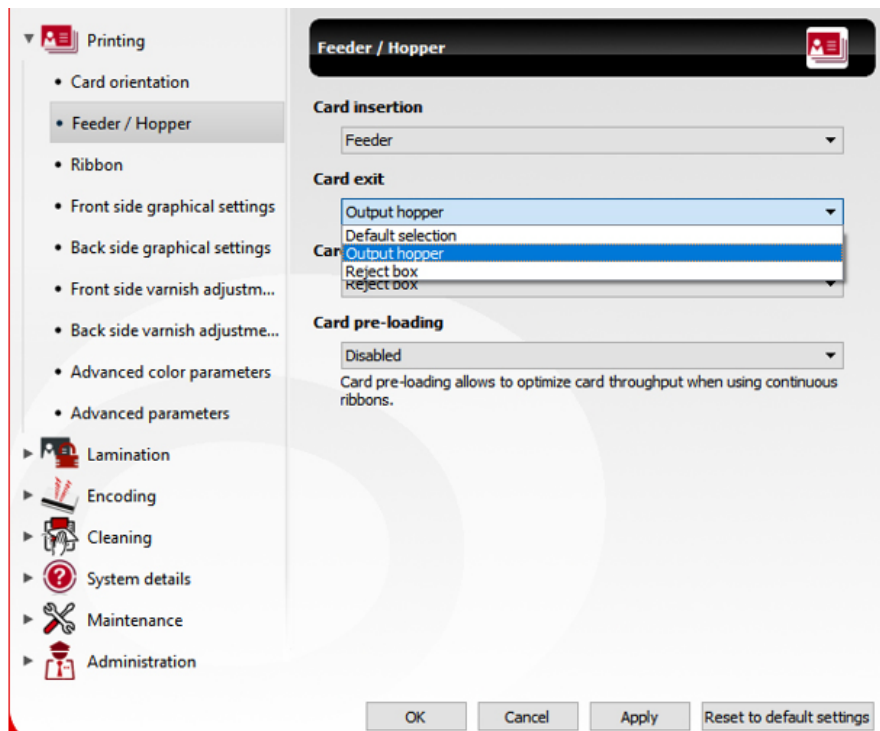

Default selection:
recommended setting

Output hopper: printer cards exit in the front output hopper

Reject box: printed cards exit in the reject box, at the rear of your printer, if it is available.

This option is also necessary when you want to use the pre-loading feature (please refer to section [Card Pre-Loading](#))⁷⁵

7.3.4.1.2.3. Card Ejection

The ejection of the card is performed at the end of a failed printing process or upon a user manual action.

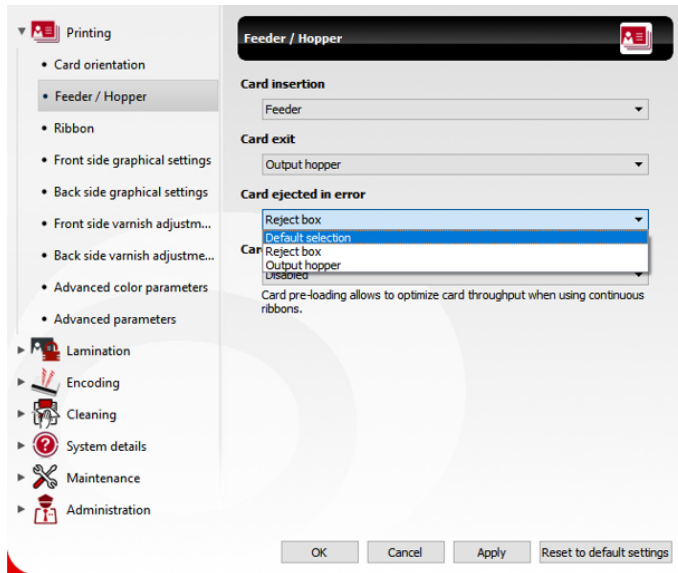

Default selection: recommended setting

Reject box: rejected cards come out in the reject box, at the back of your printer or under it, depending on its design

Output hopper: rejected cards come out in the output hopper, at the front of your printer

7.3.4.1.2.4. Card Pre-Loading



This feature is only on the following printers, equipped with a reject box: Primacy and Elypso.

Pre-loading means that up to two different cards are used by the printer at the same time:

- one is in the loading phase
- another one is in the printing phase

Pre-loading of the card is used to increase the card-feeding speed, whenever the conditions make it possible.



Two conditions must be met before using this setting:

- the Card exit setting must be defined on **Reject box**
- the ribbon used is a monochrome ribbon

Select **Enable** to set the pre-loading of the card.

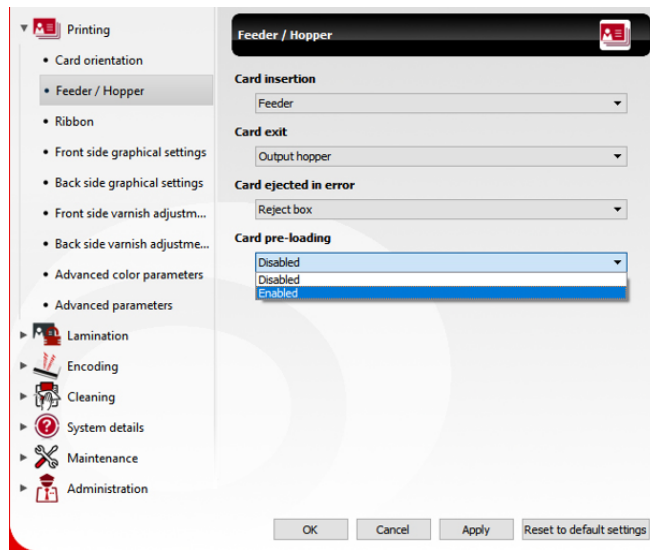

The printing process of the card is faster, as the card is ejected at the back instead of the front: its path inside the printer is only one way. In this case, you should install an output hopper on the printer:



As the ribbon used has only one color, the card does not need to go through different passes inside the printer.



The reject box has a capacity of 50 cards: please make sure to empty the box before it is full.

7.3.4.1.3. Ribbon

7.3.4.1.3.1. Ribbon Details

In Standard mode only, when you change the ribbon inside the printer, this window is automatically updated with information about the ribbon that is detected by your printer.

Evolis printers use High Trust® ribbons.

You still have the possibility to click on the refresh button displayed on the right of the window. 

The Print Center is provided with the information through the printer, which detects the ribbon through its RFID chip.

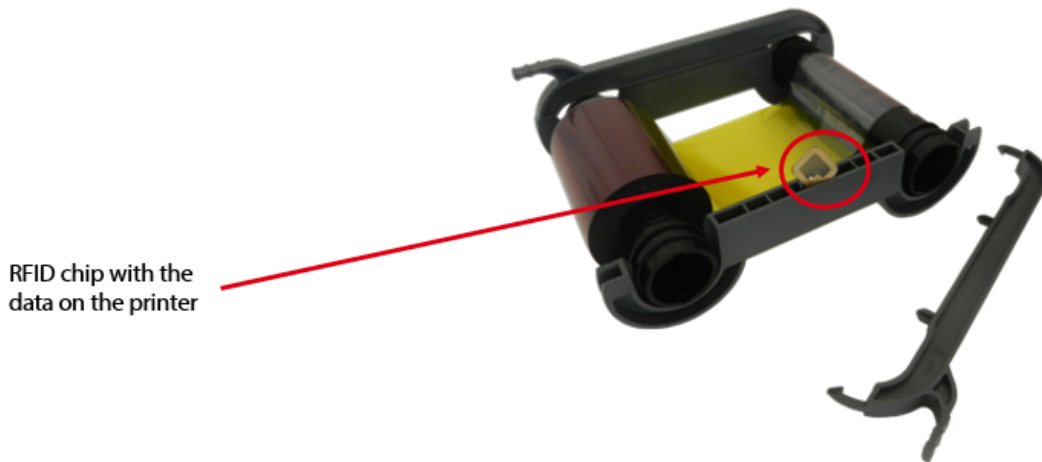

The following information are retrieved:

| Information | Meaning |
|-----------------------|--|
| Type of ribbon | There are various types of ribbons (please refer to section Ribbon Manual Settings) ⁷⁸ Not all of them can be used in your printer. Please refer to the User Guide of your printer if you have any doubt. |

| Information | Meaning |
|-----------------------------------|---|
| Zone of use for the ribbon | Each ribbon has a zone ID that is displayed on the ribbon itself. The code of the region is included at the end of the ID: EAA, AAA, SAA, S11, S22, NAA, WAA. For more details, please refer to https://www.evolis.com/consumables-card-printer/ribbons/evolis-region-code-management |



If the zone ribbon that is detected by the printer does not correspond to the zone of printer use :

- a notification pop-up is displayed by the print manager (every 10 cards)
- after 200 printed cards, printing will be limited to printer's zone only



- If the ribbon that is detected by the printer is a non-genuine Evolis ribbon:
- a notification pop-up is displayed by the print manager (every 10 cards)
 - Evolis will not guarantee printing quality and correct color synchronization

| Information | Meaning |
|---------------------------|---|
| Remaining capacity | Percentage of use that remains for your ribbon. You may check this data to avoid sudden shortage for your printing jobs. |

All ribbon details are also available in **System Details>Ribbon details**.

7.3.4.1.3.2. Ribbon Manual Settings

In MINIMAL mode only: the detection of the ribbon is not automatic: when you change the ribbon inside the printer, you need to change the ribbon settings manually.

In STANDARD mode: the detection of the ribbon is automatic. But if needed, you can still change manually the type of ribbon.



Step: Tick **Select the ribbon type** and choose the type of ribbon according to your wish.



The default settings in the Print Center are automatically adjusted according to the ribbon type.

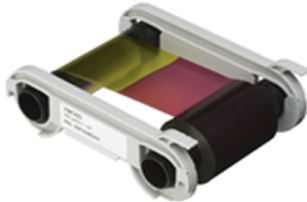

For example, if you choose a KO ribbon, the advanced color parameters window will not be available as the KO ribbon does not enable to print cards in color.

Available ribbons are the following:

| Type of ribbon | Description and Use Cases |
|---|---|
| YMCKO  | Five-panel ribbon with the following colors: yellow, magenta, cyan, black and overlay. This is the default color ribbon used in Evolis printers. Compatible printers: Zenius, Primacy, Elypso, KC200/200B  |

| Type of ribbon | Description and Use Cases |
|---|--|
| <p>SHORT YMCKO</p>  | <p>Also called half-panel ribbon It has the same colors as the YMCKO ribbon, but its panels are half the size. It is used to print half or a third of the card.</p> |
| <p>YMCKOK</p>  | <p>6-panel ribbon with the following colors: yellow, magenta, cyan, black, overlay, black Compatible printers: Zenius, Primacy, Elypso</p>  |
| <p>SHORT YMCKOK</p> | <p>6-panel ribbon with the following colors: yellow, magenta, cyan, black, overlay, black This ribbon has the same colors as the YMCKO ribbon, but its panels are half the size of the YMCKO ribbon. It is used to print half or a third of the card. Compatible printers: Zenius, Primacy, Elypso</p> |
| <p>SHORT YMCKOKO</p>  | <p>7-panel ribbon with the following colors: yellow, magenta, cyan, black, overlay, black, overlay Compatible printers: Primacy, Elypso, KC200/200B</p> |
| <p>KO</p>  | <p>Two-panel ribbon with the following colors: black and overlay Compatible printers: Zenius, Primacy, Elypso</p>  |

| Type of ribbon | Description and Use Cases |
|--|---|
| <p>MONOCHROME (black, white, red, green, blue, metallic gold and metallic silver)</p>  | <p>One-color ribbons Compatible printers: Zenius, Primacy, Elypso</p> <p style="text-align: center;">Print</p> <p style="text-align: center;">Logo & Text</p>  <p style="text-align: center;"><small>Evolis printer sample Using Monochrome Black Ribbon with SWW option</small></p> |
| <p>Hologram  Ribbon</p>  | <p>Continuous ribbon which applies a edge-to-edge hologram varnish to increase the security of the card Not compatible with smart contact cards or magnetic stripe cards Compatible printers: Zenius, Primacy</p>  |
| <p>SCRATCH OFF</p>  | <p>Continuous ribbon which produces a grey area that can be scratched off Compatible printers: Zenius, Primacy, Elypso, KC200/200B</p>  <p style="text-align: center;"><small>Evolis sample card is print with Scratchoff ribbon (Numbers are hidden Under The Patch) Scratch the patch & see the No.</small></p> <p>To use this ribbon:</p> <ol style="list-style-type: none"> 1. print a text on the card, with the ribbon of your choice 2. in your card designing software, edit an area to apply the scratch-off. Fill the area with any color. Make sure the area covers the text printed before. Place the scratch-off ribbon into the printer and print the scratch-off design |

| Type of ribbon | Description and Use Cases |
|--|---|
| <p style="text-align: center;">SIGNATURE</p>  | <p>Continuous ribbon which enables to apply a rectangular area on cards, where a signature can be written Compatible printers: Zenius, Primacy</p>  |
| <p style="text-align: center;">BLACKFLEX</p>  | <p>Black monochrome ribbon. Due to the composition of its ink, this ribbon can be used with: - standard cards: PVC, PET, PC, - and cards that cannot be printed with the traditional monochrome black ribbon: ABS, paper</p> <p>Compatible printers : Zenius, Primacy, Elypso, KC200/200B</p> <p>This ribbon is useful when the printing result with the traditional black ribbon is not the expected one, even after changing the concerned driver parameters. Please refer to section Front Side Graphical Settings for more details.</p> |

7.3.4.1.3.3. Front Side and Back Side Settings

The Duplex  mode enables the user to print your card on the front and back sides during the same printing job, with no manual action during the printing process.

Select **Enabled** in the **Duplex Mode**:

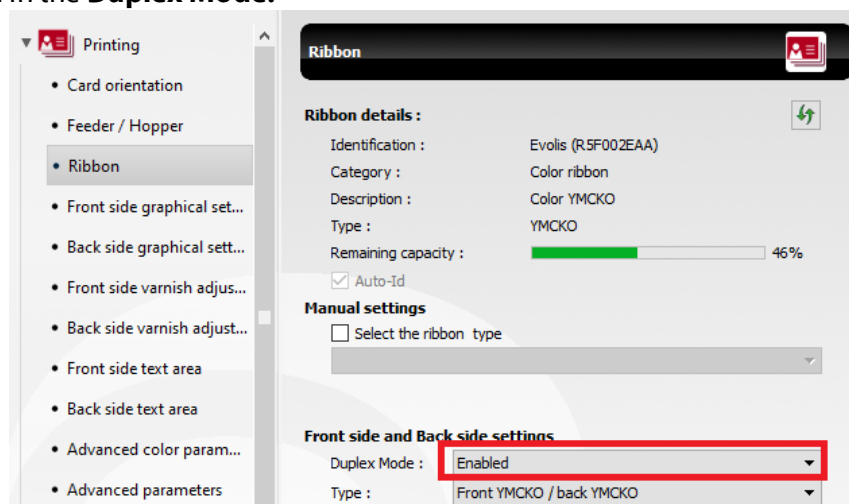

This option is used when printing on the two sides of the card: you may want to use different ribbon settings for each side.

Printers concerned can be the following ones : Primacy, Elypso.





As a consequence, it is:



- visible when your current printer has an integrated flip-over (= duplex) module
- not visible when your printer does not have an integrated flip-over (= duplex) module

To check the presence of the flip-over feature or to activate it, please refer to section [Flip-Over Activation Wizard](#) ⁶⁸

Step 1: Select the type of duplex mode according to the type of ribbon that you are using:

➤ **You are using a YMCKO ribbon (full or half):**

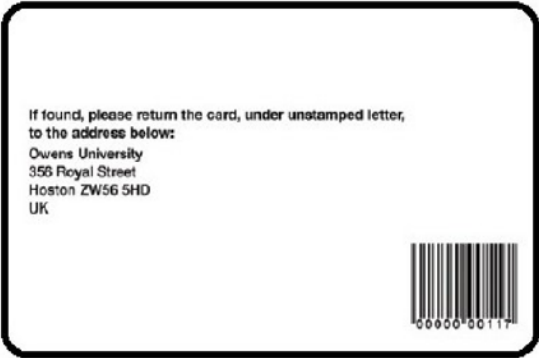
| Type of duplex mode | Use Case |
|--------------------------------|--|
| <p>Front YMCKO/ back YMCKO</p> | <p>Each side of the card is printed with different YMCKO panels .</p> <p>USE CASE</p> <p>The setting used for the Black Panel Adjustment is set on All black dots  for each side.</p> <div data-bbox="491 1081 1189 1541" style="border: 1px solid black; padding: 5px;">  <p>Photo & Background Picture in color printed with the Yellow (Y), Magenta (M) and Cyan (C) panels</p> <p>Logo and texts in real black printed with the black (K) panel</p> </div> |
| <p>Front YMCO/ back K</p> | <p>The front side is printed with the YMC colors and the overlay  will be applied on it. All black elements on the front side are printed with composite black .</p> <p>The back side is printed with the black color (K panel). No overlay will be applied to the back side (varnish option is deactivated for the back side).</p> <div data-bbox="466 1818 587 1908" style="border: 1px solid black; padding: 5px; display: inline-block;"> <p>NOTE</p> </div> <p>Selecting this option will use two YMCKO panels during the printing process and skip some colors for the back side. If you do not want to use your ribbon too quickly, we recommend that you select this option only if you really need it.</p> |

| Type of duplex mode | Use Case |
|-----------------------------------|---|
| | <p>USE CASE</p> <p>For the front side: by default, the setting used for the Black Panel Adjustment is set on No real black printed.</p> <p>For the back side: by default, the setting used for the Black Panel Adjustment is set on Black and White, but you can select another option (please refer to section Black Panel Adjustment)^[87].</p> <div style="text-align: center;">  </div> <p>Photo & Background Picture in color printed with the Yellow (Y), Magenta (M) and Cyan (C) panels</p> <p>Logo and texts in Yellow (Y), Magenta (M) and Cyan (C) panels</p> <p>K panel is particularly adapted to barcodes and QR codes. Make sure to insert them on the back side, with this option.</p> <div style="text-align: center;">  </div> <p>Back Side Data Like Text & Barcode is printed with the (K) Panel</p> |
| Front YMC/ back KO | <p>The card front side is printed with the YMC colors, and the back side is printed with the KO (black and overlay) panels.</p> <p>The only difference with the previous option is that the overlay is applied on the back side and not on the front side (varnish option is deactivated for the front side).</p> |
| Custom front color/ back color | <p>With these options, the varnish  settings are set by default on No varnish on both sides of the card.</p> |

| Type of duplex mode | Use Case |
|--|--|
| Custom front color/ back monochrome | To change these settings, please go to sections Front Side Varnish Adjustment ⁹⁰ and Back Side Varnish Adjustment ⁹³ . |
| Custom front monochrome/ back monochrome | |
| Custom front monochrome/ back color | |



It is strongly recommended to avoid printing flat colors on any of the card sides. Always make sure to add patterns or characters to your flat color. Indeed, flat color only causes the print head to warm too much as there is no other design detail to lower the heat of the print head. This issue may cause the ribbon to be stuck on the card and torn.

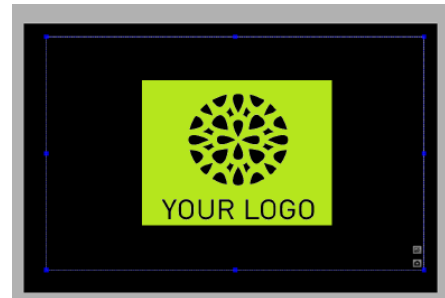
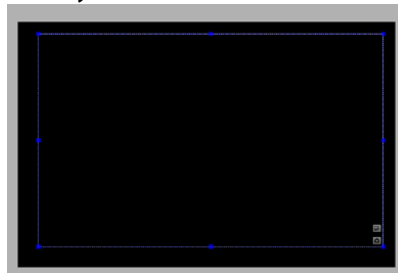

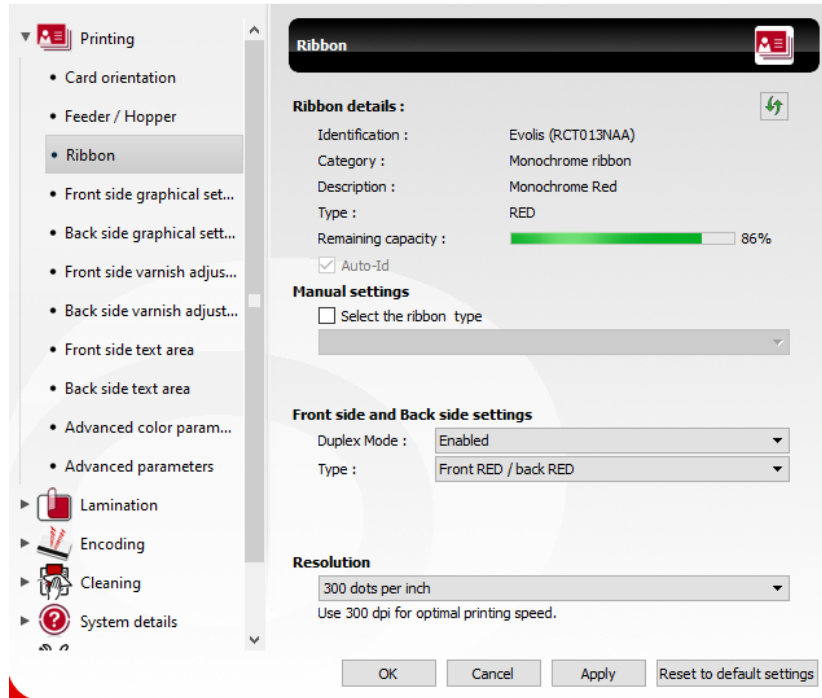

➤ **You are using a monochrome ribbon**

Both sides are printed with the same color and no varnish  option is possible as there is no overlay panel in the ribbon





Step 2: Check the settings in **Front Side Varnish** and the **Back Side Varnish** windows. Select **Full Varnish** if you want both sides of the card to have the varnish protection.



Never use the varnish  option on the side of a card that is already laminated. It would not be useful and would produce various issues, including card jamming, tearing of ribbon, unsticking of lamination  film, etc.

7.3.4.1.3.4. Printing Resolution

Step: Select the type of resolution:

| Resolution | Use Cases |
|---|---|
| <p>300x300 dpi </p> <p>(size of design in pixels: 1016x648)</p> | <p>Default resolution, adapted to most printing jobs and printers</p> |
| <p>600x300 dpi </p> <p>(size of design in pixels: 2032x1296 size of printing rendering in pixels: 2032x648)</p> | <p>Adapted to printing jobs on most printer, if the size of your design resolution is bigger</p> <p> NOTE Finer details can be printed, but the card printing process may be slowed down.</p> |

| Resolution | Use Cases |
|--|---|
| | |
| <p>1200x300 dpi (size of design in pixels: 4064x2592 size of printing rendering in pixels: 4064x648)</p> | <p>Only when using monochrome ribbons, especially with a design of:</p> <ul style="list-style-type: none"> - small characters in text areas - high resolution |





1 dot = 0,12 mm

7.3.4.1.4. Front Side/Back Side Graphical Settings

Those settings will enable you to adjust the color panels, so as to get the most optimal printed result.

The Ribbon details tab provides the name of the ribbon currently detected in the printer.

To enable the back side graphical settings, make sure to enable the **Duplex**  Mode in the **Ribbon** menu (for more details, see section [Front Side and Back Side Settings](#)) .

7.3.4.1.4.1. Brightness and Contrast

Step: Adjust the brightness and contrast of your colors.

| Feature | Use Case |
|--|--|
| Brightness of colour panels  | Increases the overall lightness of the image. |
| Contrast of colour panels | Increases the overall darkness of the image. The higher is the contrast, the higher is the printing heat. |



7.3.4.1.4.2. Black Panel Adjustment

Two menus are available, depending on the parameters selected in the **Ribbon** window.

Option #1: A color ribbon is selected to print the current side.

The user has two possibilities:

- using a pure black color (RGB code above 253)
- using a mix of colors (yellow, magenta and cyan panels): it is called composite black 

There are three different parameters associated with these two possibilities:

| Feature | Use Cases |
|-------------------------------|---|
| Black Panel Adjustment | no real black printed: the black panel (K) is not used during the printing process. Only composite black is used. It is especially useful for designs with only images |

| Feature | Use Cases |
|---------|-----------|
|---------|-----------|



Settings: No real black, front side with YMCO panels

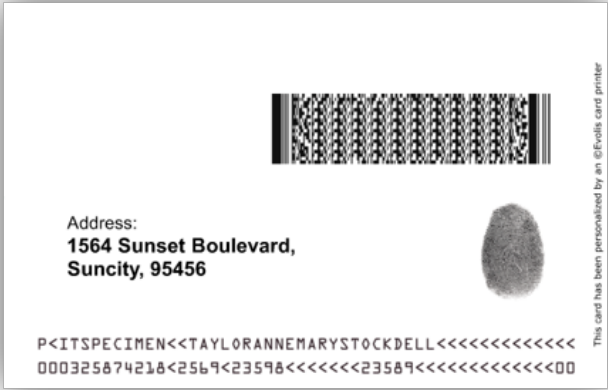

Settings: back side with K panel



all black dots : the black panel (K) is used for the whole design (text area, images)



Settings: All black dots, front side with YMCKO panels

only black text: the black panel (K) is used only for text areas and barcodes

| Feature | Use Cases |
|---------|--|
| | <div style="text-align: center;">  </div> <p style="text-align: center;">Setting: Only black text, front side YMCKO</p> |

If you have selected all black dots  or only black text, you may need to adjust the resin monochrome setting. This setting is directly linked to the print head heat and to the thermal transfer  technique.



In case you want to print barcodes or text areas with small characters, the printing result must be more accurate.

You may need to:





- increase the resin adjustment (by default it is set on 10),
- decrease the printing speed.

| | |
|-----------------|--|
| USE CASE | <p>Printing a document format that does not detect text areas (e.g. .pdf)</p> <p>Please refer to sections Front Side Text Area ⁹³ and Printing Black Text: Use of Different Softwares ⁹⁶</p> |
|-----------------|--|

Option #2: A black ribbon is selected for the current side.

There are four different halftoning  parameters:

| Feature | Rendering |
|-------------------------------|---|
| <p>Black and White</p> | <div style="text-align: center;">  <p>Black & White</p> </div> |

| Feature | Rendering |
|--|---|
| Grayscale |  Grayscale |
| Dithering  |  Dithering |
| Clustered Dithering  |  Clustered Dithering |

When applying pure black color on the card, the monochrome resin adjustment is increased or decreased in order to improve the density of the black color on the card.

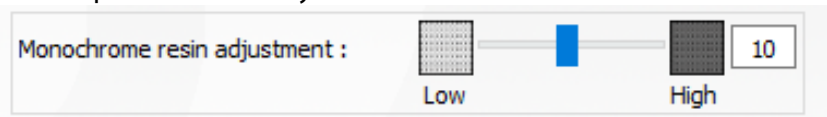







7.3.4.1.5. Front Side Varnish Adjustment

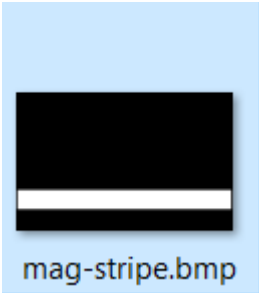

The varnish (= overlay) , is available for all types of ribbons apart from the continuous ribbon (as it does not have an overlay panel).

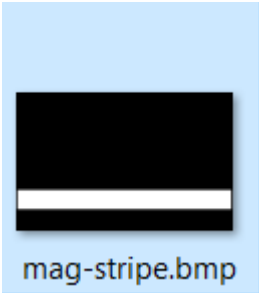
The varnish adjustments window allows you to adjust the varnish coating on cards and where to apply varnish on cards.

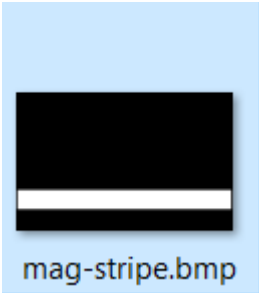
The purpose is to protect the card from UVs and to increase resistance of cards to scratching and fading up.

| Feature | Steps to follow /Rendering |
|--|---|
| No varnish No varnish is applied on the printable area.  Printed card is more exposed to wear and tear | As it is not possible to print on a card side that was varnished, use the No varnish option when you want to print: <ol style="list-style-type: none"> 1. the "background" pattern in a first printing job 2. then the text in defined areas in a second printing job When all printing jobs are finished on the card, you may go to Full Varnish or Custom bitmap option. |

| Feature | Steps to follow /Rendering | | | | | | | |
|--|--|--|---------------|---------|--------------------------------|--|----------------------------|--|
| <p>Full varnish The printable area is covered with varnish.</p> | <p>Use this option if you have finished printing the patterns and texts on you card.</p> <p>In case you want to check that you have applied an overlay on your card, check the brightness of the card.</p> <p>TIP: A bright card indicates that an overlay was applied, as it reflects the light of the environment.</p> | | | | | | | |
| <p>Custom bitmap You select a format to apply the overlay on the card</p> <p>Applying an overlay with a custom bitmap is especially useful when you have a magnetic or smart encoding on your card.</p> | <p>Step 1: Varnish type>Custom bitmap</p> <p>Step 2: Select the format:</p> <table border="1" data-bbox="576 667 1449 1619"> <thead> <tr> <th data-bbox="576 667 815 707">Format option</th> <th data-bbox="815 667 1449 707">Meaning</th> </tr> </thead> <tbody> <tr> <td data-bbox="576 707 815 1619"> <p>overlay/backover</p> </td> <td data-bbox="815 707 1449 1619"> <p>The varnish is applied according to the selected picture:</p> <ul style="list-style-type: none"> - black area indicates the varnish coating - white area gets no varnish <p>The selected file has to:</p> <ul style="list-style-type: none"> - be a monochrome bitmap file - have a size of 1016 x 648 dots <div style="text-align: center;">  <p>mag-stripe.bmp</p>  </div> </td> </tr> <tr> <td data-bbox="576 1619 815 2051"> <p>custom_afnor</p> </td> <td data-bbox="815 1619 1449 2051"> <p>Only if you use a card with a chip</p> <p>No varnish is applied on the location of the chip , as specified by the AFNOR standard The location of the chip is displayed in white on the card template.</p> <p>The template also serves as a reference to view the AFNOR standardized location.</p> </td> </tr> </tbody> </table> | | Format option | Meaning | <p>overlay/backover</p> | <p>The varnish is applied according to the selected picture:</p> <ul style="list-style-type: none"> - black area indicates the varnish coating - white area gets no varnish <p>The selected file has to:</p> <ul style="list-style-type: none"> - be a monochrome bitmap file - have a size of 1016 x 648 dots <div style="text-align: center;">  <p>mag-stripe.bmp</p>  </div> | <p>custom_afnor</p> | <p>Only if you use a card with a chip</p> <p>No varnish is applied on the location of the chip , as specified by the AFNOR standard The location of the chip is displayed in white on the card template.</p> <p>The template also serves as a reference to view the AFNOR standardized location.</p> |
| Format option | Meaning | | | | | | | |
| <p>overlay/backover</p> | <p>The varnish is applied according to the selected picture:</p> <ul style="list-style-type: none"> - black area indicates the varnish coating - white area gets no varnish <p>The selected file has to:</p> <ul style="list-style-type: none"> - be a monochrome bitmap file - have a size of 1016 x 648 dots <div style="text-align: center;">  <p>mag-stripe.bmp</p>  </div> | | | | | | | |
| <p>custom_afnor</p> | <p>Only if you use a card with a chip</p> <p>No varnish is applied on the location of the chip , as specified by the AFNOR standard The location of the chip is displayed in white on the card template.</p> <p>The template also serves as a reference to view the AFNOR standardized location.</p> | | | | | | | |

| Feature | Steps to follow /Rendering |
|-------------------------------|---|
| | <p>You can still browse a bitmap file if you need to use your own format of varnish that would be more adapted to your user needs.</p>  <p>Keep in mind that your customized bitmap file may not be compatible with the AFNOR standard anymore.</p> |
| custom_iso | <p>Only if you use a card with a chip</p> <p>No varnish is applied on the location of the chip , as specified by the ISO standard The location of the chip is displayed in white on the card template.</p> <p>The template also serves as a reference to view the AFNOR standardized location. You can still browse a bitmap file if you need to use your own format of varnish that would be more adapted to your user needs.</p>  <p>Keep in mind that your customized bitmap file may not be compatible with the ISO standard anymore.</p> |
| custom_mag | <p>Only if you use a card with a magnetic stripe</p> <p>No varnish is applied on the magnetic stripe, as specified by the ISO standard The location of the stripe is displayed in white on the card template.</p> <p>The template also serves as a reference to view the AFNOR standardized location. You can still browse a bitmap file if you need to use your own format of varnish that would be more adapted to your user needs.</p>  <p>Keep in mind that your customized bitmap file may not be compatible with the ISO standard anymore.</p> |
| Step 3: Click on Apply | |

7.3.4.1.6. Back Side Varnish Adjustment

The use of this window and the feature is the same as explained in section [Front Side Varnish Adjustment](#)⁹⁰.

USE CASE

You may want to apply a varnish on the back if your card is especially submitted to frictions.

For example, the repeated insertion in a reader, of a card equipped with encoding  capacities, may cause scratches to appear.

Applying the overlay  on both sides of the card will add a useful protection.

7.3.4.1.7. Front Side/Back Side Text Area

This feature enables to define a text area when you want to print a document format that does not detect the text areas (typically, .pdf documents) and you need to print those text areas in pure black (in opposition to composite black .

Please note that the behaviour is different according to the software used to print your card design. For a comparison of softwares on the printing of images and text areas, please refer to section [Printing Black Text: Comparison of Softwares](#)⁹⁶.

NOTE For the window to be editable, you need to select **Only black text** in the **Front side graphical settings** window.

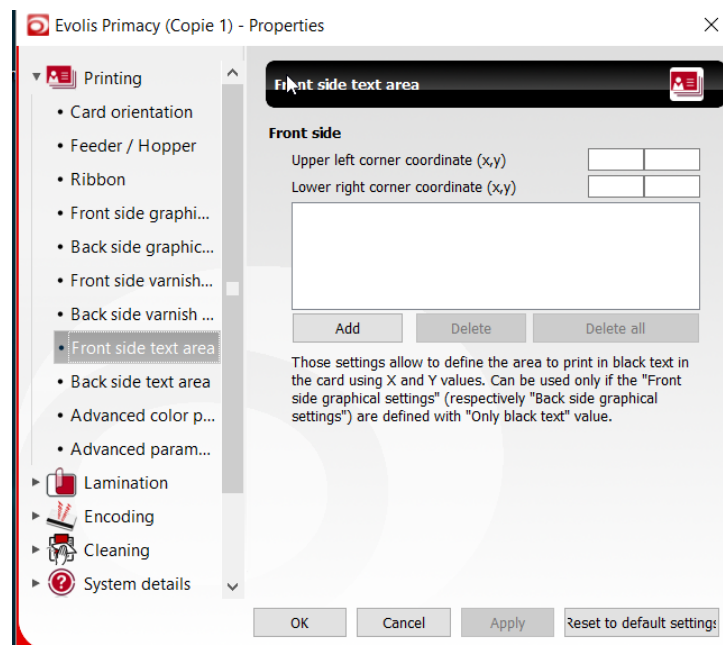

STEPS TO FOLLOW

To define your text areas (10 areas as a maximum), you need to set two points (upper left and lower right) according to their coordinates (x, y) in pixels.

Step 1: Open the image you want to insert in a graphic software that includes a pixel ruler such as **Paint**.

Step 2: Retrieve the coordinates of:

1. the point on the top-left of the area
2. the point on the bottom-right of the area

Step 3: Go back to the **Front Side/Back Side Text Area** window and enter the coordinates in the following fields:

1. upper
2. lower

Step 4: Click on **Add** and **Ok**.

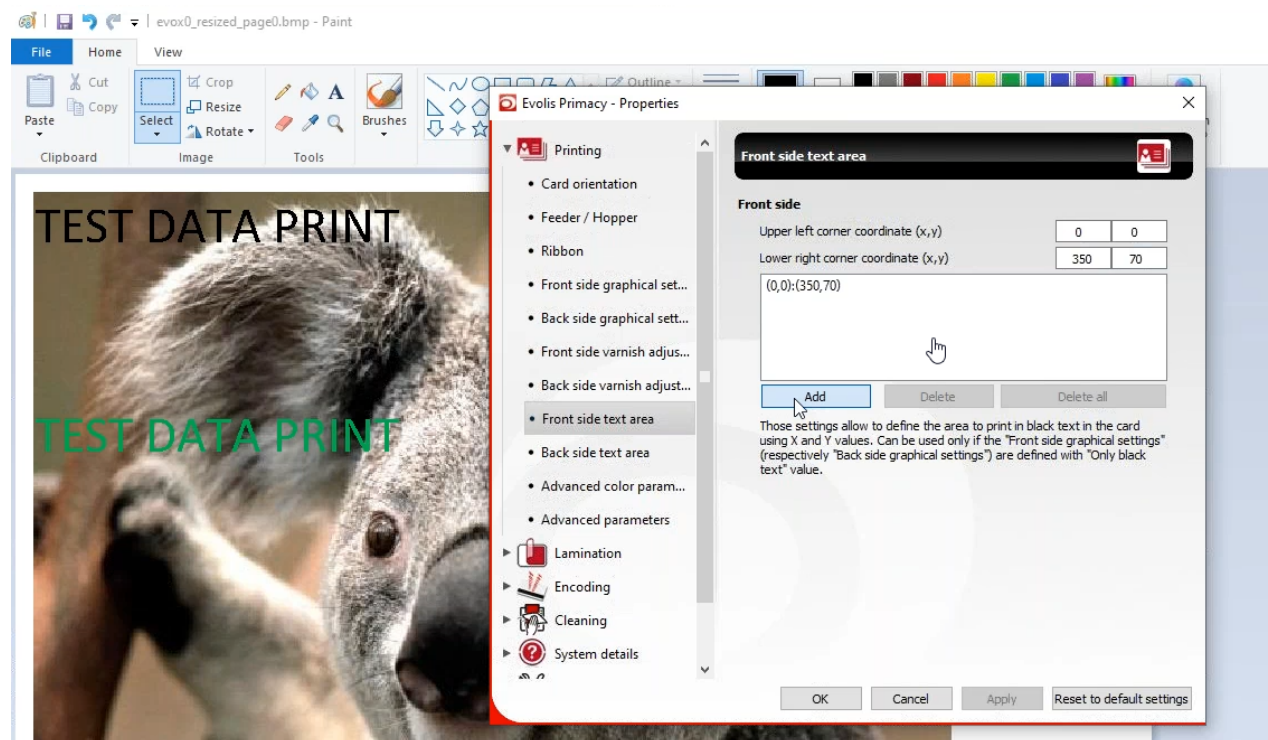

Step 5: Go back to your document and click on **File>Print**.

In the **Print** settings, check that the selected orientation is the one that is adapted to your design orientation.

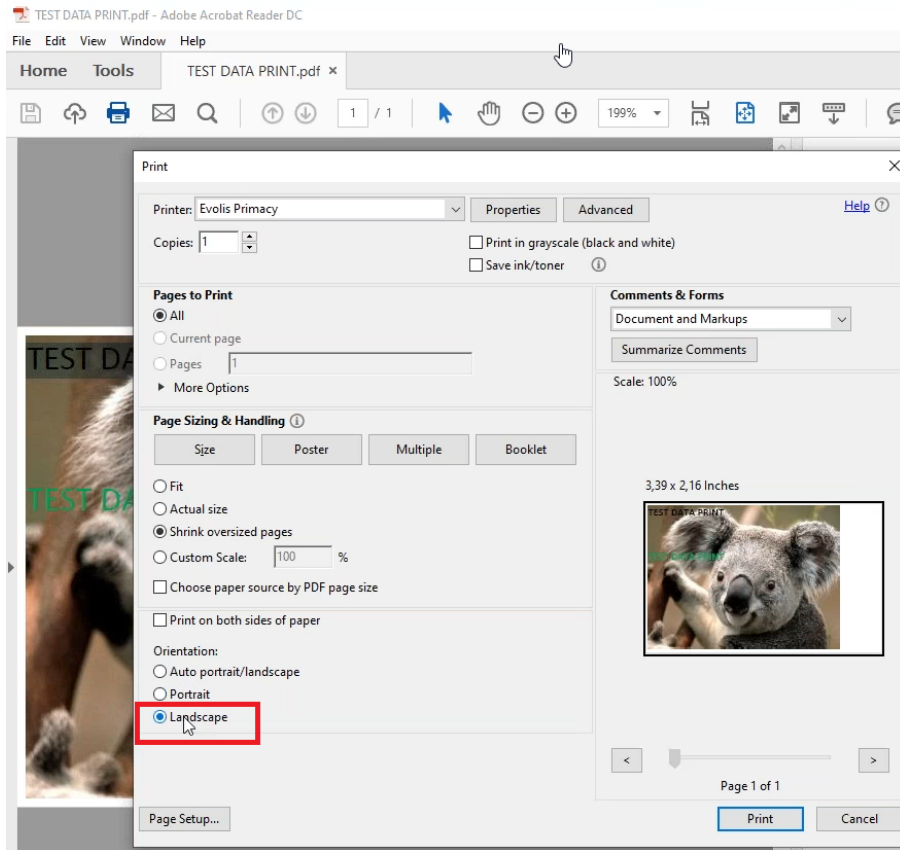

Step 6: Click on **Print**.

Your card will be printed as follows:

- black text areas in pure black
- other areas in color (black color will be printed in composite black )



When defining a text area, you display a location where all black dots  will be printed in pure black, even if these black dots belong to the background and not to the text.

If you do not want the background to be printed in pure black, there are two solutions:



- select another area with a background that do not include black dots
- use an image editor software to change the status of the background RGB colors (for more details, go to USE CASE [Changing the Background RGB levels](#)) ⁹⁵

7.3.4.1.7.1. Changing the Background RGB levels

The objective here is to change the background RGB levels of your image in the software you are using, so that black dots  are under the level detected by Evolis driver: 253.

MATCHING OF COLOR MODELS AND THEIR MANAGEMENT:

| COLOR | Thresholds in RGB model | Thresholds in YMC model | PRINTING MANAGEMENT |
|-----------|--|-------------------------|--|
| K (black) | managed as black dots RBG <253 | YMC >128 | thermal transfer  technique |

| COLOR | Thresholds in RGB model | Thresholds in YMC model | PRINTING MANAGEMENT |
|--|---|-------------------------|---|
| O (overlay)  | managed as black dots RGB <253 | YMC >128 | thermal transfer technique |
| color panels | managed as white dots RGB ≥253 | YMC <128 | dye sublimation  technique |

USE CASE

In the provided example, the software used is **GIMP**.

But you may use another software, as long as you adapt the procedure to its own parameters.

Step 1: From the buttons displayed on the left part, click on the background color.

A pop-up window called **Change the background color** is displayed.

Step 2: In the RGB fields, select **0...255** option, then set the levels at **252** for RGB colors. Click on **Ok**. The EPS will not detect black dots in the background anymore; all background dots will be printed with the YMC panels.

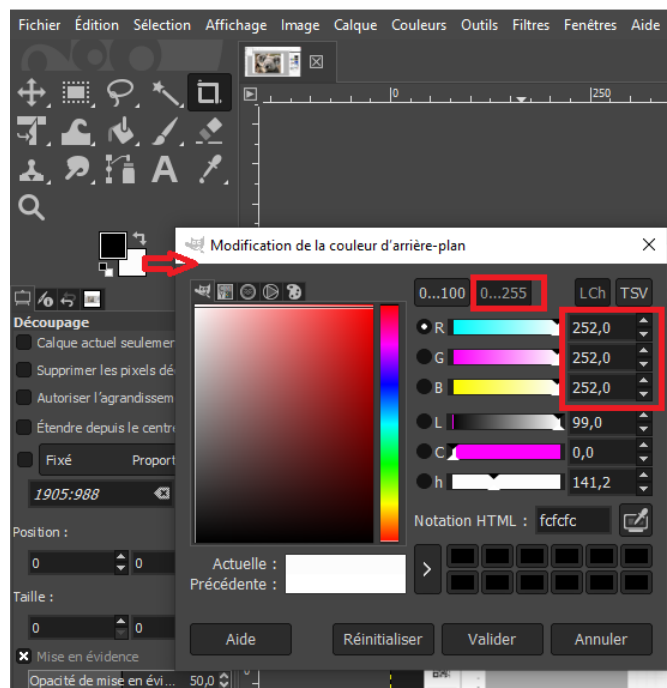

Step 3: Click on **Export** as and do not forget to tick **Save the background color**.

Step 4: Now you can go back to the procedure explained in section [Front Side Text Area](#)⁹³ to define the text areas.

7.3.4.1.7.2. Printing Black Text: Use of Different Softwares

This section will compare various software used when printing black text areas, and explain the best parameters to use in the EPS driver.

The use case is to print a design that contains a background image and black text area: the image must be printed in color and the text must be printed in black.



Example of Card Design with Image and Text Areas

Some softwares detect the difference between text areas (bitmap) and images (vectorial) while others do not.

Depending on the software you are using to design your card, you will need to set specific settings in [Black Panel Adjustment](#)⁸⁷.



Once you have set the adequate parameters for your printing job, you may save them in a .dat file and retrieve them on another computer (for more details, please refer to section [Printer Driver Settings](#))¹⁴⁶.

1. Cardpresso

Text areas and images are detected.

It also works without black dots  on the images. It means that the RGB code used for the image black areas is under 253.

Step 1: Do not forget to set the image as a background.

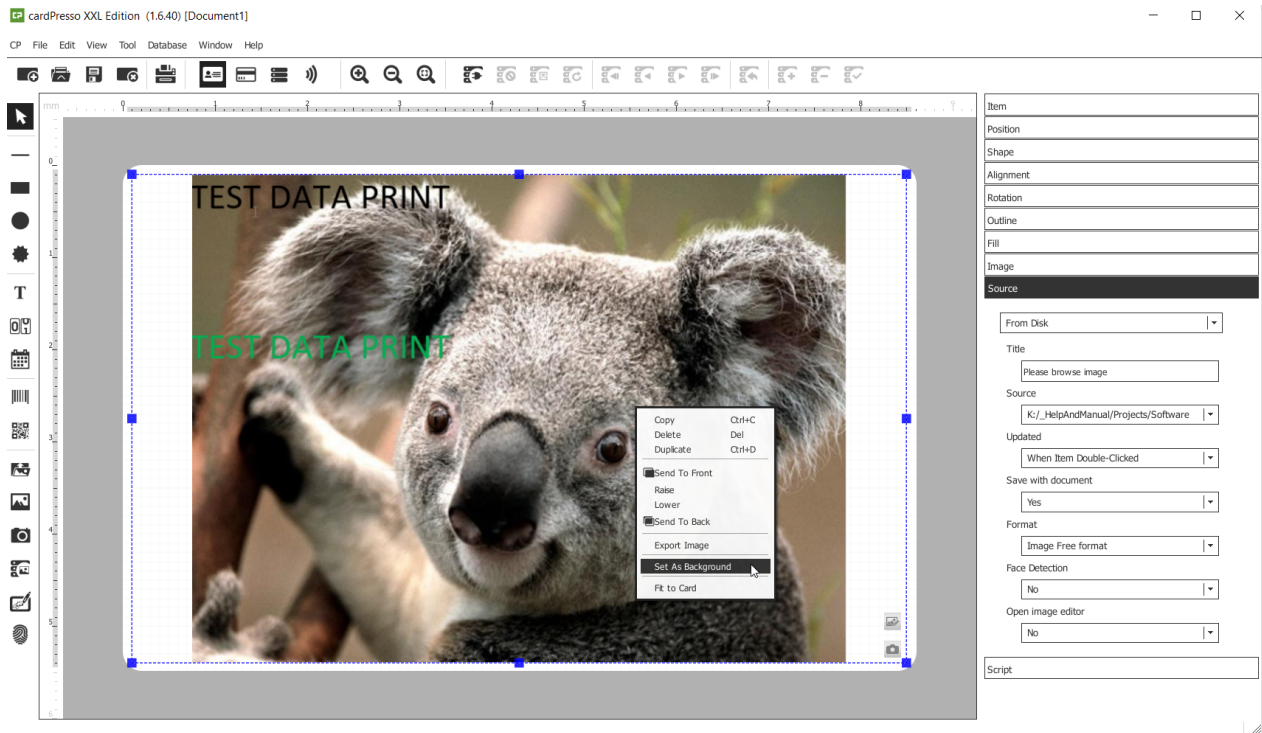

There is no setting to configure in [Black Panel Adjustment](#)⁸⁷ section.

Step 2: Click on **File>Print**.

2. Word

Text areas and images are detected.

Step 1: In Word software, set the page format through page **setup>Size>More Paper Sizes>width**: 8.5, length: 5.4, margins: 0.1 cm

Step 2: In Evolis Properties, set **Black Panel Adjustment** on **Only black text**.

Step 3: From Word, click on **File>Print**.

3. PDF

Difference between text areas and images is not detected.

Step: For the procedure to define a text area, please refer to section [Front Side Text Area](#)⁹³.



Pdf parameters may interfere with the final rendering. For more details, see section [Card Design Software with Interfering Options](#)¹⁵⁶

4. Paint

Difference between text areas and images is not detected.

Step 1: Check that your image size in pixels is 1016x646 or 2032x1296 (according to the resolution that you want to print) and save it.

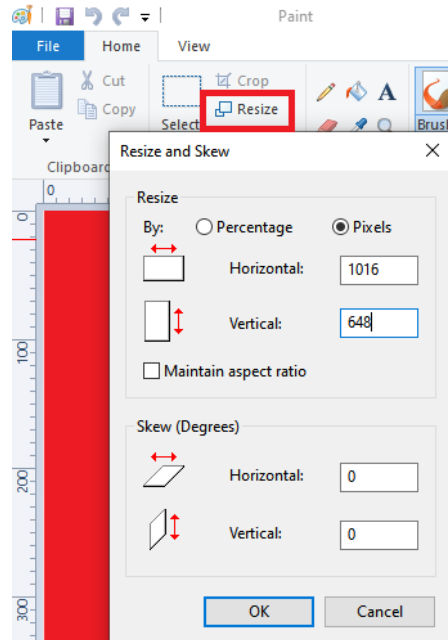

Step 2: For the procedure to define a text area, please refer to section [Front Side Text Area](#)^[93].

Step 3: Directly from the image icon, right-click and click on **Print**.



Do not open Paint software to click on **File>Print**. The final rendering of the image size would not be adequate.

7.3.4.1.8. Advanced Color Parameters

7.3.4.1.8.1. Smoothing

Smoothing  is used to make more even the curbs on the pattern, so as to get a clearer print rendering on the card.

There are three smoothing levels: standard, advanced and none.

Smoothing is used to apply smoothing after the driver detection of the black dots  parts and color parts on the card design.

It is applied only on the colored dots and is particularly useful in case of a design with a detailed image (landscape or photo).

Step 1: Select the settings according to your design and system configuration:

- By default, **Standard** smoothing is the selected setting, in order to get the best printing quality in most cases.
- **None** may be selected when the design to be printed is a black monochrome one or when your design is better without smoothing.
- **Advanced** smoothing (only available for Primacy, Elypso and KC200 printers) is selected whenever the design is colored and detailed, especially in case of photos.

Examples of printing rendering:



No smoothing



Standard



Advanced

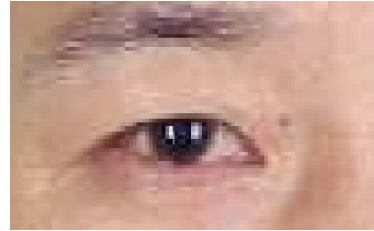
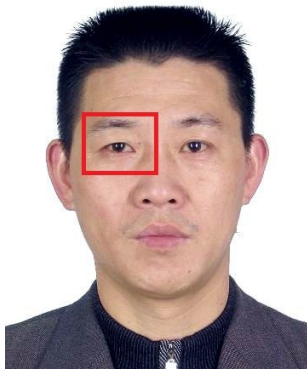

No smoothing

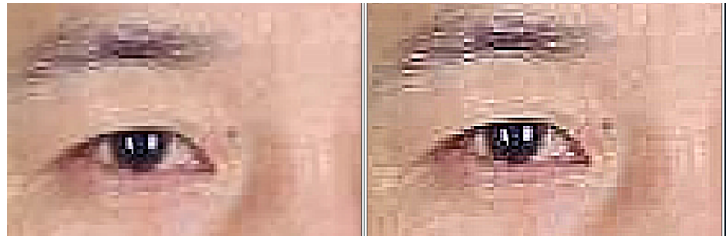

Standard

Advanced



No smoothing

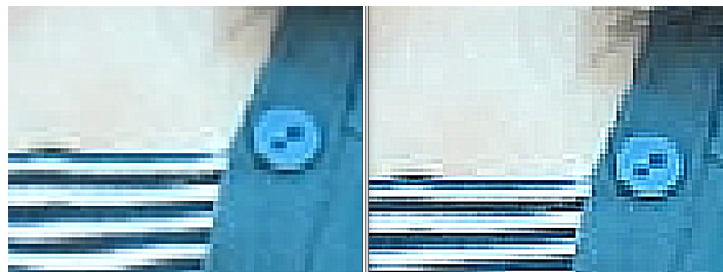

Standard



Advanced

Step 2: Once you have selected the adequate settings, click on **Apply**.



Evolis card design softwares such as Cardpresso also offer the possibility to apply anti-aliasing , in **Print Settings>Rendering>Antialiasing**.

The setting is most commonly set on **Only Images**. It means that:

- images on your design will be anti-aliased and printed with the dye sublimation  technique
- text area on your design will be printed with the technique of monochrome resin thermal transfer 

For more information on this setting, please refer to the **User Guide** of each software.

Step 3: You can now perform the printing job.

7.3.4.1.8.2. Short Panel Management

This feature is activated when using a half-panel ribbon to print full-color elements and black elements.

- The color area must not exceed 35mm in width and 54 mm in height.

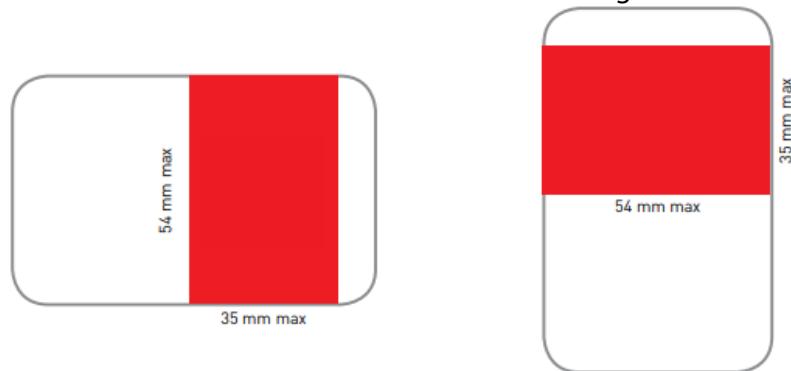

- Black elements (texts, barcode, logo etc.) to be printed with the black panel must be detected by the EPS as pure black dots .

These black elements can be placed anywhere on the card. All black dots must be selected in the black panel management (see section [Black Panel Adjustment](#))

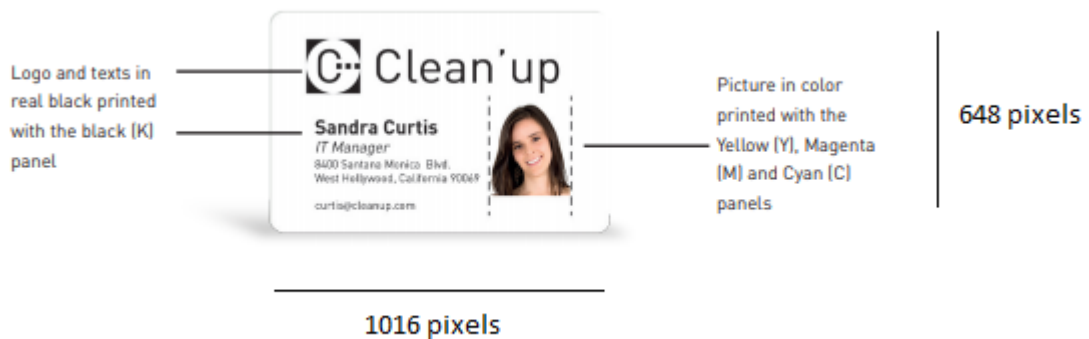

The short panel management menu enables the user to define the starting point of the colored panels of the ribbon.



As a reminder, the printing process always starts on the first panel of the YMC colors.

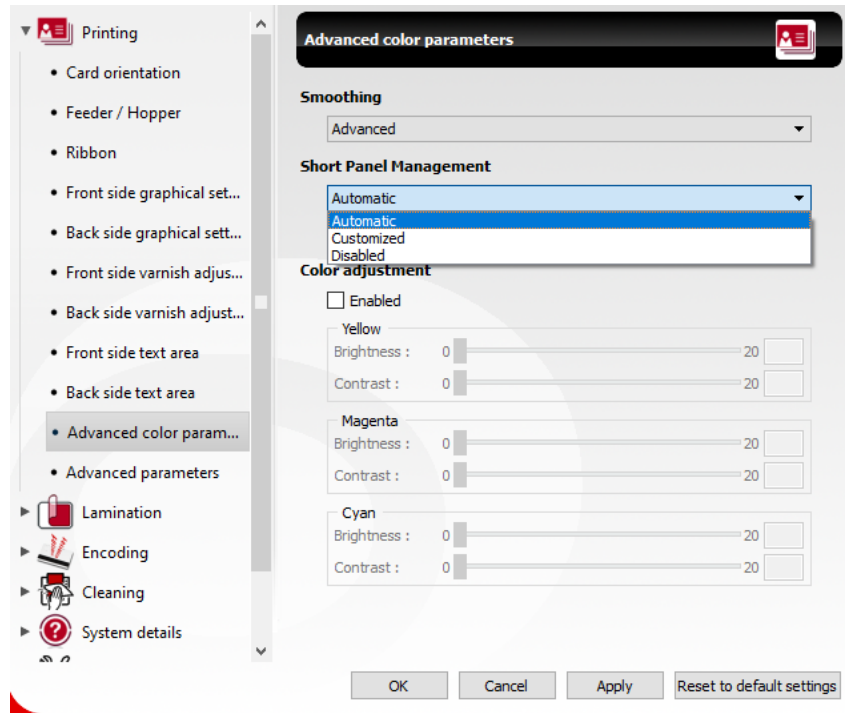

Three options are possible:

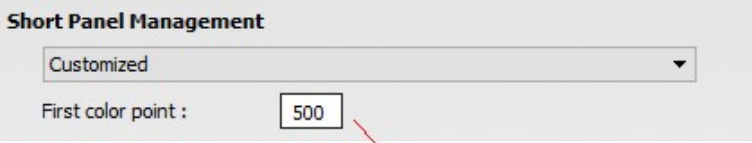
| | |
|-------------------|--|
| Automatic | Default option Colored panels start being used for printing: whenever a colored dot is detected (even if this dot is not visible to the naked eye). |
| Customized | The user defines the pixel that will be the starting point for the use of the colored panels.  <p>In this example, colored elements start at 500 pixels from the edge of the card</p> |
| Disabled | Colored panels start being used for printing: from the first edge of the card. |

NOTE If your card design has a black element first and a colored element in the second half of the card, you can change the orientation option (rotate by 180°) to print the colored element first.

7.3.4.1.8.3. Color Adjustment

This section enables to adjust the Yellow, Magenta, Cyan panel colors (brightness and contrast) independently.

7.3.4.1.9. Advanced Parameters

Monochrome printing speed can be adjusted if you are using a monochrome ribbon. Reducing the printing speed results a slower moving of the card under the print head, and thus in increasing the adhesion of the ink on the card.

For a concrete use case, see [Unreadable Barcode](#) [159] in the Troubleshooting section.



This feature is not used to increase the speed of your overall printing process (for this, please go to section [Card Pre-Loading](#)) [75].

7.3.4.2. Lamination

The process of lamination consists in applying a polyester film onto a card surface in order to:

- protect it from wear and tear, UV rays,
- fight forgery.

The protection lasts for 2 to 10 years, depending on the thickness of the chosen film.

It can be applied on one side or both sides of the card.

The lamination module may be used in two different modes of installation: [Printer-Connected Mode](#) [105] or [Standalone Mode](#) [106].

In Standard Mode, the Print Center displays all useful statuses on the printer and on the lamination module on the same line.

For example, "no ribbon" means that the ribbon is missing in the printer, whereas "no film" means that the film is missing in the lamination module.

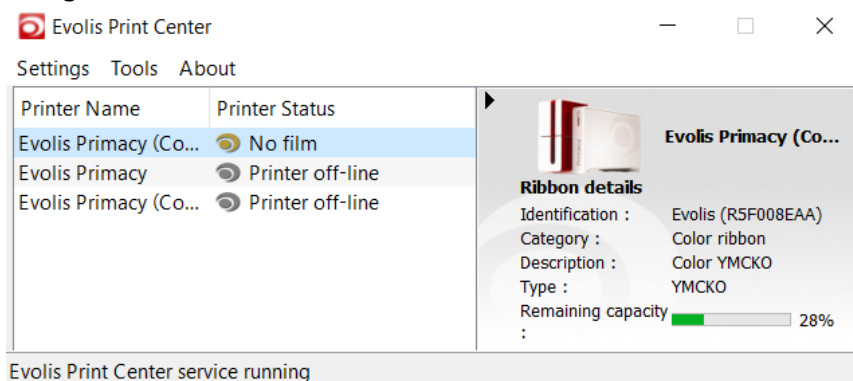

Please refer to section [Description of Print Center Interface](#) [63] for the description of the icon colors.

As described in the **Primacy Lamination User Guide**, you can also refer to the LED/LCD statuses if the device is available on the lamination module:



Please note that:

- the LCD device is not available in the lamination standalone mode
- in printer-connected mode, only one LCD is possible on one of the devices

7.3.4.2.1. Printer-Connected Mode



The printer and the lamination module communicate through infrared connectors. The printer is the "master unit" and the lamination module is the "slave unit". In this mode, you will only see the printer line in the Print Center/ only the printer device in the Devices list on your OS, because the printer is the one that communicates with the Print Center.



Please make sure to always connect the cable of the lamination module first.

From the Print Center, if the **Lamination** menu is not activated, make sure to disconnect the printer and its lamination module, then reconnect the lamination module firstly and the printer secondly.

For more details on the installation of the lamination module and its driver, please refer to the **User Guide** of your printer.

7.3.4.2.2. Standalone Mode

The lamination module can work as a standalone module if it is directly connected to the computer through a USB connection.

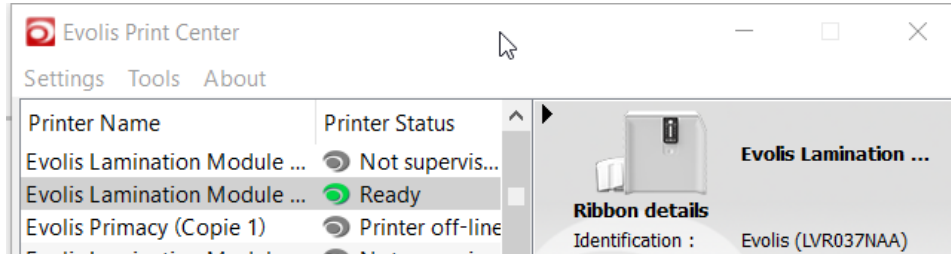

In this case, the module settings menu can be accessed through a double-click on **Evolis Lamination Module**.





The settings and menus are the same as proposed for the lamination module in "printer-connected mode".





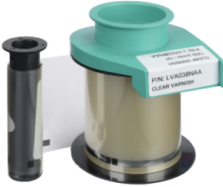

In standalone mode, the insertion of cards into the lamination module is a manual action.

7.3.4.2.3. Types Of Lamination Films

There are various types of lamination  films. They are all compatible with PVC or composite cards.

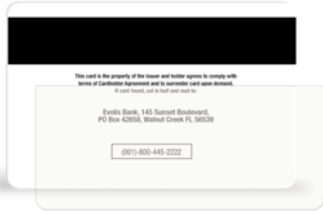
Their use depends on your specific needs.

| Type of film | Options | Use |
|---|---|--|
| Varnish  | Clear | <ul style="list-style-type: none"> - continuous ribbon - single or dual side - edge-to-edge covering - not compatible with contact or magnetic stripe cards |
| Patch   | Full Clear patch  | <ul style="list-style-type: none"> - single or dual-sided lamination - on the full printable surface of the card (no cut on the patch) - for cards without encoding option or contactless smart cards |
| | Clear Smart Cut Patch | <ul style="list-style-type: none"> - single side lamination only - with a chip cutout - for contact smart cards |

| Type of film | Options | Use |
|--------------|---|--|
| |  | |
| | <p data-bbox="483 589 807 622">Clear Alternate Cut Patch</p>   | <ul data-bbox="890 589 1433 909" style="list-style-type: none"> - dual-sided lamination only - 3 alternate patches configurations: <ul style="list-style-type: none"> • Smart/Full : Layout for smart contact cards with a full back • Smart/Mag: Layout for smart contact cards with a magnetic stripe on the back • Full/Mag: Layout for cards with a magnetic stripe on the back (full front) |
| | <p data-bbox="483 1200 831 1234">Generic Holographic Patch</p>  | <ul data-bbox="890 1200 1433 1469" style="list-style-type: none"> - ribbons in PET - single or dual-sided lamination - not compatible with smart contact cards or magnetic stripe cards - registered generic hologram . Artwork already created (Generic Globe Design), - composed of security features of level 2. <p data-bbox="890 1503 1449 1603">The generic holographic patch ribbon is the standard holographic ribbon provided by Evolis.</p>  |

| Type of film | Options | Use |
|--------------|--------------------------------|---|
| | Customized holographic patches | Customized films may be created on demand. For more details, please refer to Custom Hologram Ribbons Guide . |

7.3.4.2.4. Lamination Settings

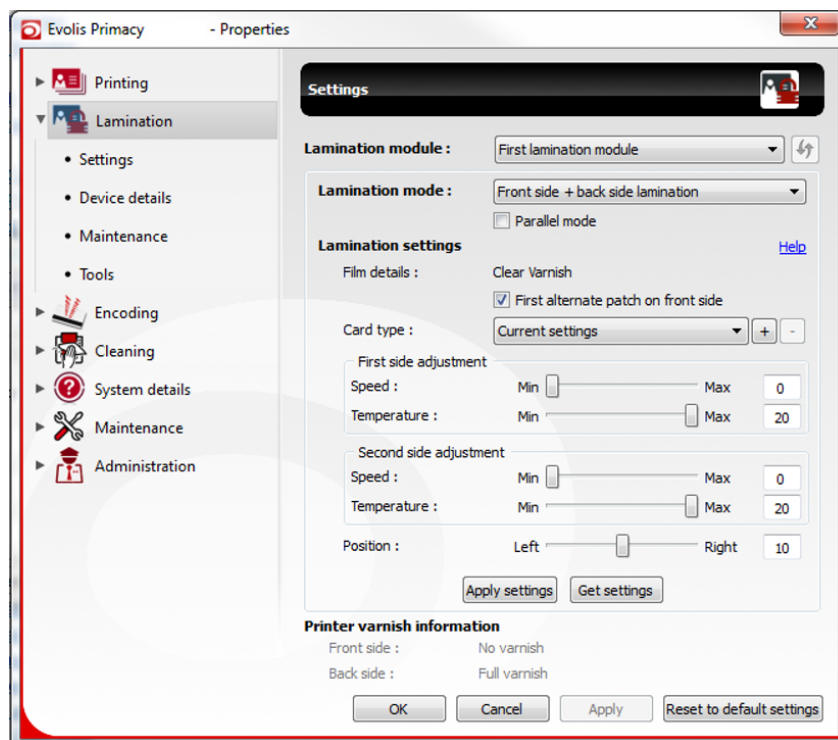

Step 1: Select the lamination module (first or second, as two lamination modules may be installed with the printer).

Step 2: Select the lamination process mode.

Reminder of the front side and back side of a card:

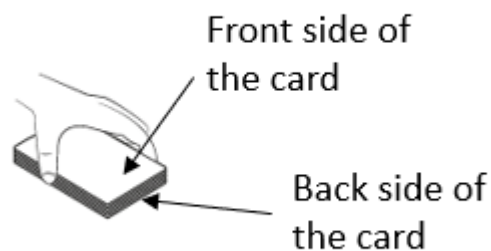

The options are detailed below:

| Lamination printing mode | Meaning and use case |
|--|--|
| No lamination | Lamination is not applied on the card |
| Front side lamination | Lamination is only applied on the front side (up side) of the card |
| Front side lamination + flip | <ol style="list-style-type: none"> 1. Lamination is applied on the front side (up side) of the card 2. The card is flipped and ejected on the other side of the card |
| Back side lamination | Lamination is applied on the back side (down side) of the card |
| Back side lamination + flip | <ol style="list-style-type: none"> 1. Lamination is applied on the back side (down side) of the card 2. The card is flipped and ejected on the other side of the card |
| Front side + back side lamination | <p>Default option.</p> <ol style="list-style-type: none"> 1. Lamination is applied on both sides of the card, starting with the front side (up side) 2. The card is ejected with the back side of the card up (last side laminated) |
| Back side + front side lamination | <ol style="list-style-type: none"> 1. Lamination is applied on both sides of the card, starting with the back side (down side) 2. The card is ejected with the front side of the card up (last side laminated) |

Parallel mode  is ticked by default when a printer and a lamination module are connected to each other.

A new card starts being printed as soon as the previous card has entered the lamination module. This mode optimizes card production as the printing and lamination modules operate simultaneously. It is particularly useful when you want to laminate big batches of cards.

Parallel Mode

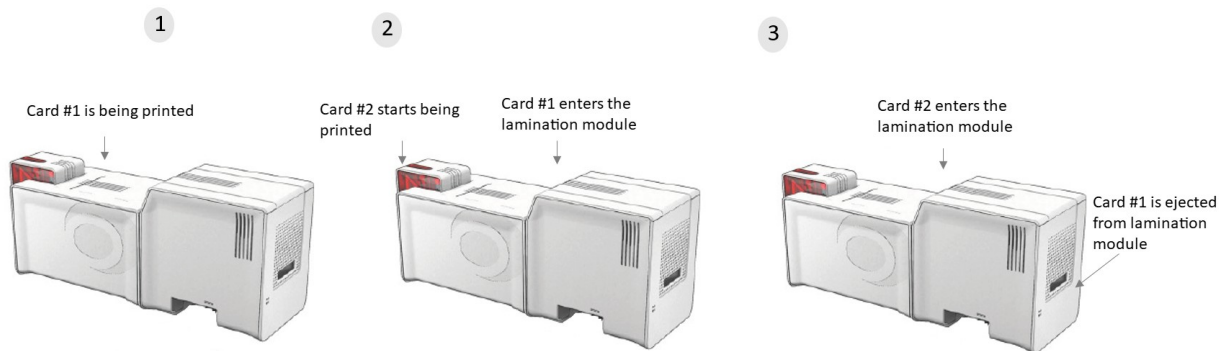

Untick the **Parallel mode** checkbox if you want a new card to start being printed after the previous card has been laminated.

This mode can make the printing process slower, but it can be used to control production flows and to correct customization in the event of an error.



Please check that:

- you have connected the power cable of the printer **after** the power cable of the lamination module, so as to enable the detection
- both printer and lamination module are on a flat surface and aligned with each other

Step 3: Select the lamination settings.

| Settings | Meaning |
|--|---|
| Film details | Automatic detection of the lamination ribbon inserted into the module previously selected in Step 1 . |
| First alternate patch on front side | Tick this option if you are using a patch with alternate film. |
| Card type | Select the type of card. Depending on the card, the adjustments are different. For example, if you use polycarbonate cards, the temperature is higher as Click on + to add a new card type preset. Enter a name and click on Ok to display it in the list. |

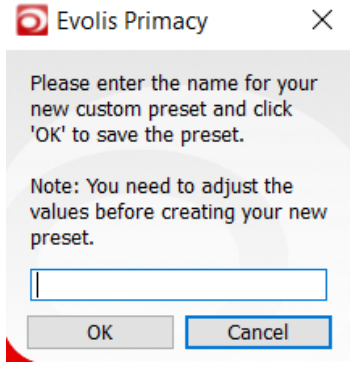
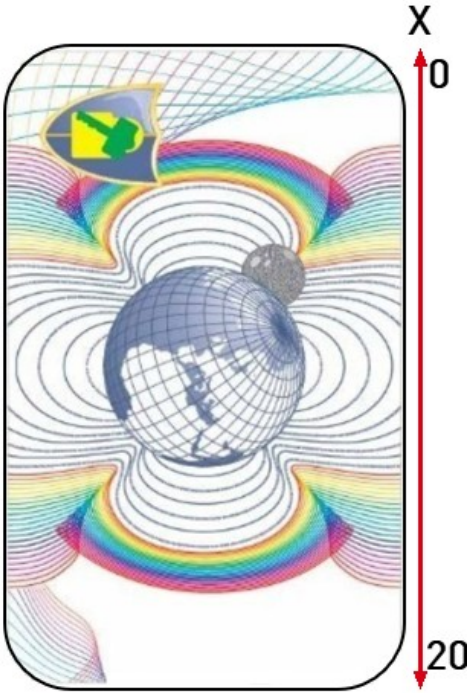
| Settings | Meaning |
|---|---|
| |  <p>Click on - to delete the custom preset.</p> |
| <p>Speed adjustment [not expressed in measuring units]</p> | <p>You can increase the speed of lamination if you want a better adhesion of the lamination patch on the card.</p> |
| <p>Temperature adjustment [not expressed in measuring units]</p> | <p>You can lower the temperature of lamination if you want a better adhesion of the lamination patch on the card.</p> |
| <p>Position</p> | <p>Adjust the x offset settings. The film is adjusted along the card length, as indicated below:</p>  |



Once you have set the **Lamination settings**, Do not forget to click on **Apply settings** to confirm your adjustments.

Step 4: Check the **Printer varnish information**. It corresponds to the overlay  settings that are defined in **Printing** > [Front Side Varnish Adjustment](#) ^[90] and [Back Side Varnish Adjustment](#) ^[93].

Step 5: Go to your card design and click on **Print** to start the printing and/or lamination process.

When the first cards are printed, the temperature of the lamination module may be adjusting, as indicated in **Evolis Print Center**:

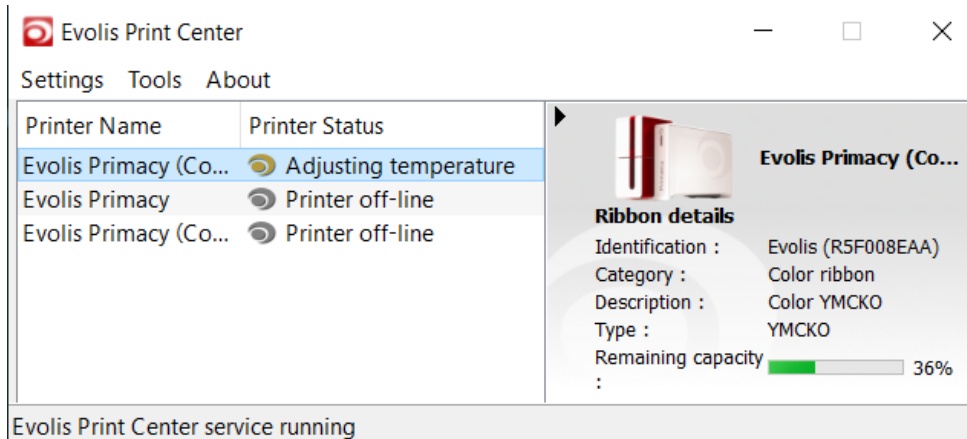

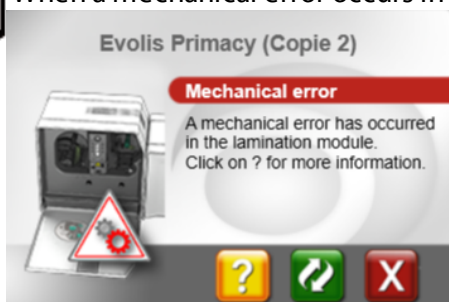

When a mechanical error occurs in the lamination module, a pop-up is displayed.

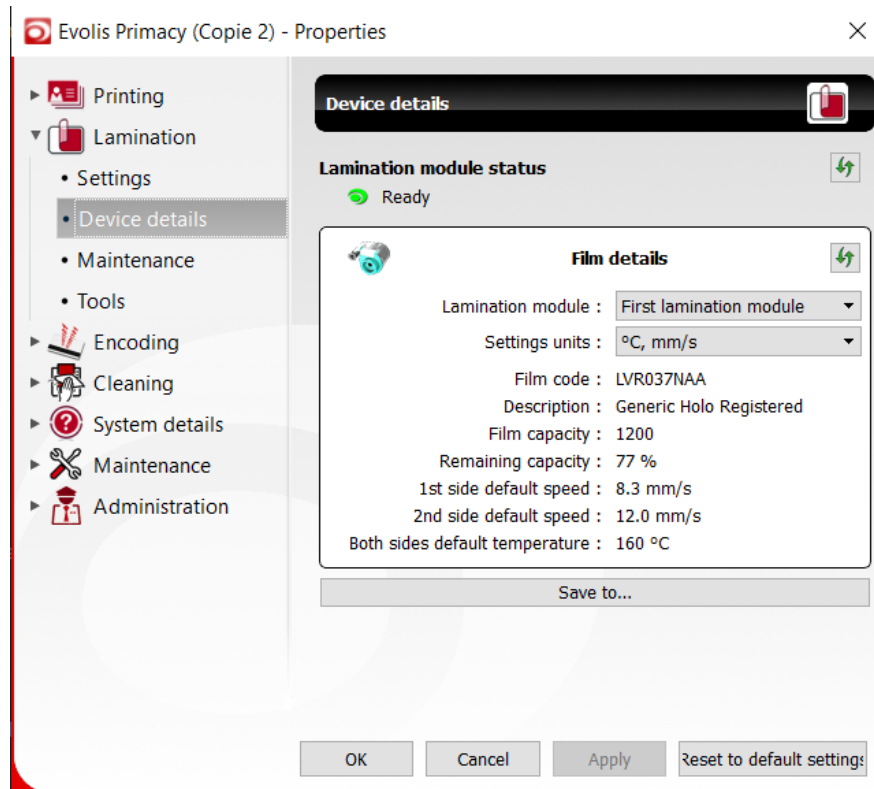

To solve the issue, please click on the **Refresh** button.
If this action does not solve the issue, 1. restart the lamination module ; 2. restart then the printer.

7.3.4.2.5. Lamination Device Details



Step 1: Select the lamination  module (first or second, as two lamination modules may be installed with the printer) to get all details on your lamination module.

Step 2: Set the measuring units for the display of the film details.

| Film Details | Meaning |
|--|---|
| Film code | Film identification (including the zone of use) |
| Description | Type of lamination films, as detailed in section Types Of Lamination Films ¹⁰⁶ |
| Film capacity | Number of prints that are available in the current film roll. 1 print = 1 side |
| Remaining capacity | Percentage of use that remains for your film roll. You may check this data to avoid sudden shortage for your printing jobs |
| 1st side/2nd side default speed | The second side default printing speed is usually lower than the first side default printing speed. Indeed, the heating temperature is already optimal when the second side of the film is being stucked on the card. Using the same temperature on both sides may cause a bad card printing result |
| Both sides default temperature | Temperature used to stick the lamination film |

Step 3: To export the details into a .txt file, click on **Save to** and enter a name for the file.

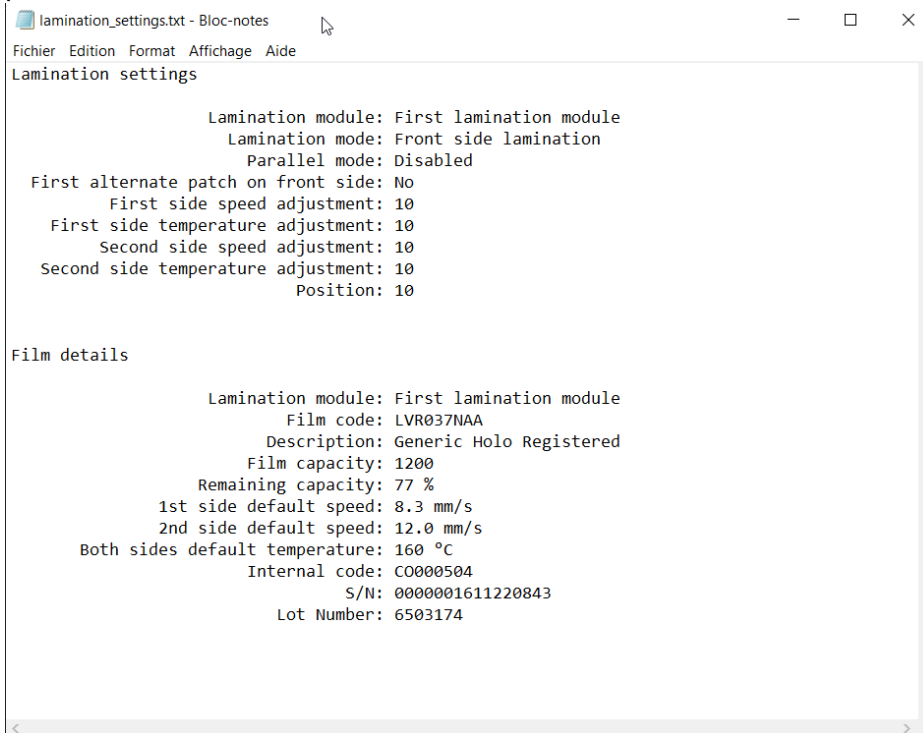

```
lamination_settings.txt - Bloc-notes
Fichier Edition Format Affichage Aide
Lamination settings

          Lamination module: First lamination module
          Lamination mode: Front side lamination
          Parallel mode: Disabled
First alternate patch on front side: No
  First side speed adjustment: 10
  First side temperature adjustment: 10
    Second side speed adjustment: 10
    Second side temperature adjustment: 10
      Position: 10

Film details

          Lamination module: First lamination module
          Film code: LVR037NAA
          Description: Generic Holo Registered
          Film capacity: 1200
          Remaining capacity: 77 %
    1st side default speed: 8.3 mm/s
    2nd side default speed: 12.0 mm/s
  Both sides default temperature: 160 °C
    Internal code: C0000504
      S/N: 0000001611220843
      Lot Number: 6503174
```



Please send this file to the [Support](#) team in case you encounter an issue.

7.3.4.2.6. Lamination Maintenance

This window deals with various types of maintenance :

- checking the status of the sensors adjustment through commands
- updating the firmware through a wizard
- performing the cleaning task

7.3.4.2.6.1. Checking the Status of the Sensors Adjustment through Commands



Please refer to the Service Manual of Primacy Lamination to get the list of main commands of adjustment that are available for the lamination module.

Step 1: Enter the command and click on **Send** or **Enter**.



Before sending the commands, please make sure that you have inserted a ribbon and cards.

If you send the command to adjust the cover sensor, do not forget to open and close the cover just after sending the command.

If you send the command to adjust all sensors:

- do not forget to open and close the cover just after sending the command, as the first sensor to be checked is the cover one
- check that you have fed the lamination module with a continuous patch  that has black marks (example: generic holographic patch). Otherwise, the driver will not be able to perform the whole adjustment and you will have to restart the lamination module and the printer.

Step 2: Wait for the answer.

If the answer is an **ERROR:**

1. check that you have followed the indications of the above warning
2. contact your reseller or Evolis [Support](#) team



Never untick the **Direct communication** checkbox.

Step 3: Use the **Eject card** button in case the card was stuck into the lamination module and you want to eject it at the back.

7.3.4.2.6.2. Updating the Lamination Firmware

The procedure is slightly different according to the mode of lamination you are using: printer-connected or standalone mode.

Step 1: Click on **Launch the update wizard** and follow the indications:

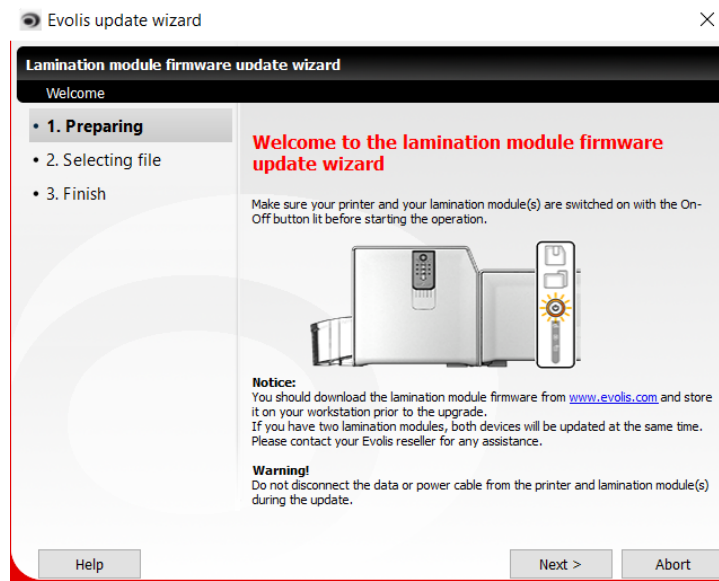

Step 2: To find the most recent lamination firmware on www.evolis.com, go to **Drivers&Support>Card Lamination Module**.

You may download:

- either the CLM firmware (if you are using the lamination module attached to the printer)
- or the stand-alone firmware tool

Do not forget to unzip the downloaded file and click on **Next**.

Step 3: Browse for the firmware update file and click on **Next**.

The lamination firmware is being updated. Wait for the update to finish.

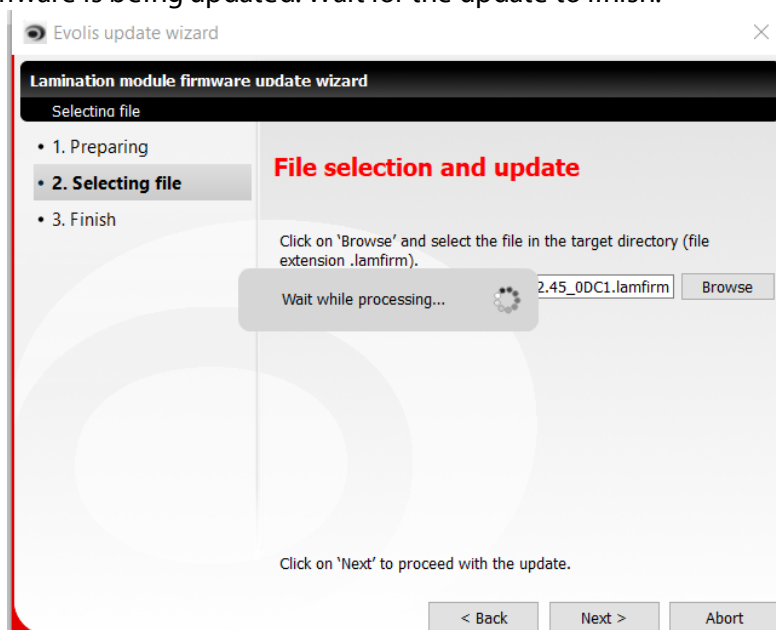

Step 4: Check that the firmware version was updated: if you are using the lamination module in printer-connected mode, go to **System Details**.

NOTE Do not forget to click on the **Refresh** button. 

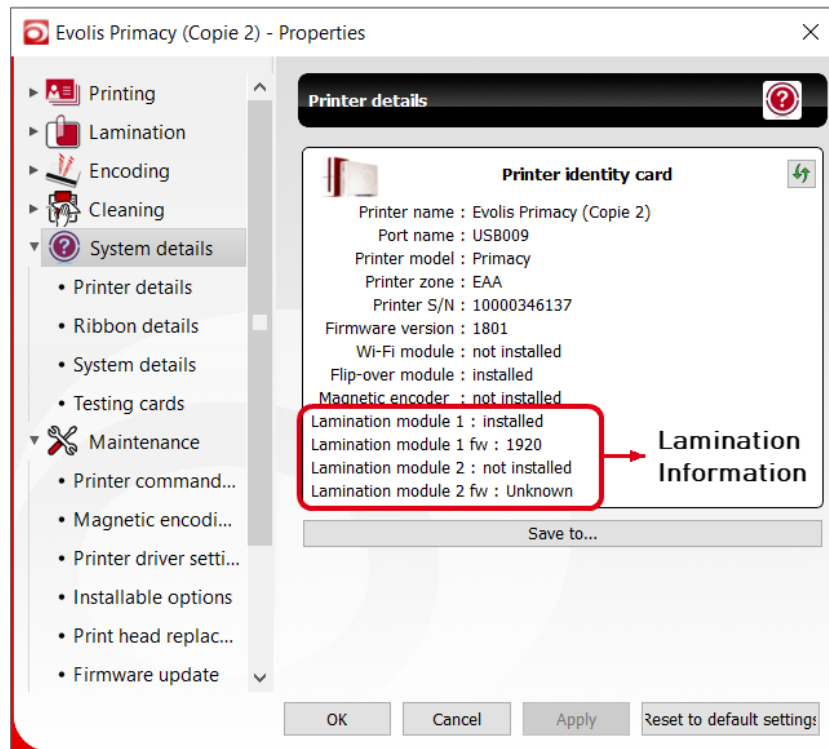

Step 1: To find the most recent lamination firmware on www.evolis.com, go to **Drivers&Support>Card Lamination Module**.

You may download:

- either the CLM firmware (if you are using the lamination module attached to the printer)
- or the stand-alone firmware tool

Do not forget to unzip the downloaded file and click on **Next**.

Step 2: Click on the **Browse** button to search for the firmware file and click on **Update**.

Step 3: Check that the firmware version was updated: go to **System Details** and click on **Save to**. The exported file reads the version of firmware of the lamination module.

7.3.4.2.6.3. Performing the Cleaning Task for Lamination

Cleaning is required every 5000 inserted cards



Before starting the cleaning, make sure that you have a double-sided adhesive card.

- **In Printer-connected mode**

Follow the steps below to start a cleaning cycle :

Step 1: Remove the lamination film (please refer to the **User Guide** for the procedure of removal).

Step 2: From the Print Center, go to **Maintenance**> **Start cleaning** (the wizard is also available from the **Tools** menu).

Step 3: Follow the indications of the wizard:

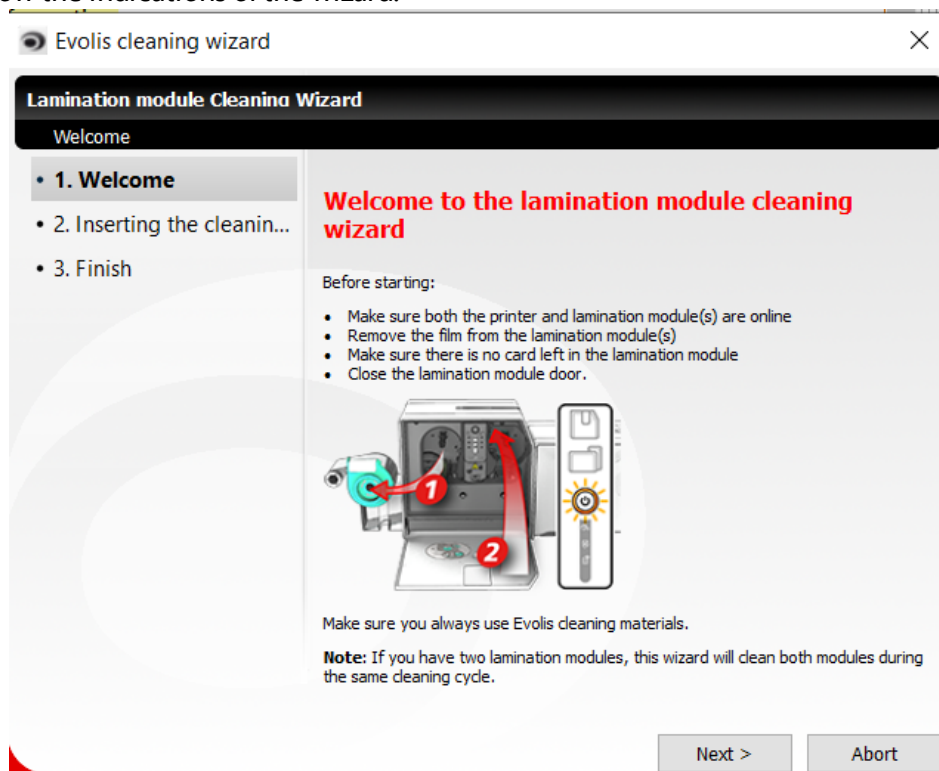

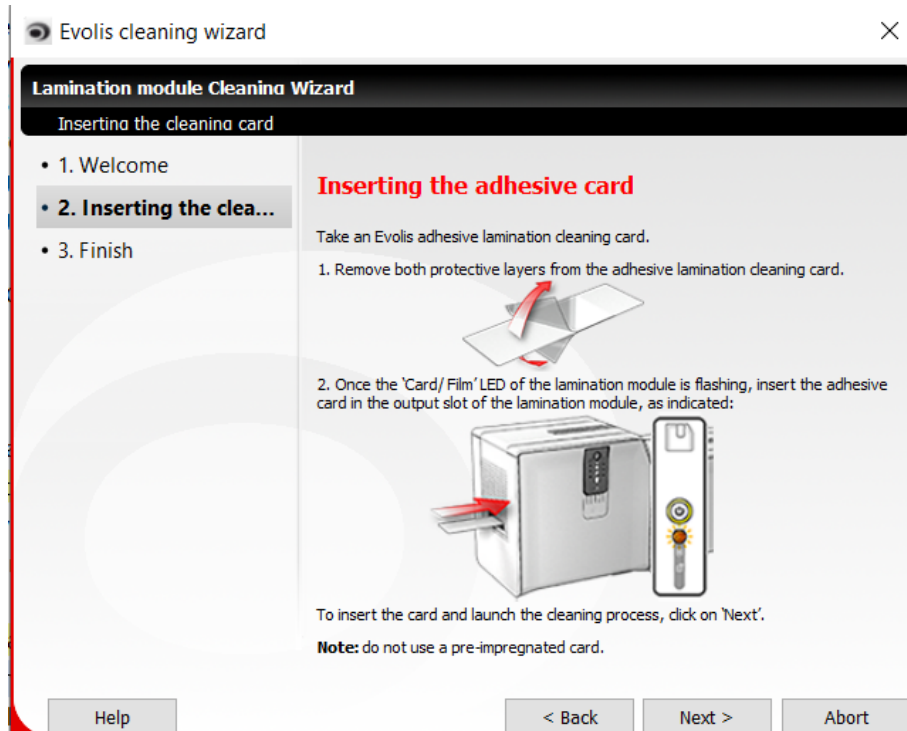

At the end of the cleaning process, the cleaning card is ejected from the output hopper.

NOTE Do not forget to re-insert the lamination film(s) in the module(s). Please follow the indications of the **User Guide** for the procedure of insertion of the film.

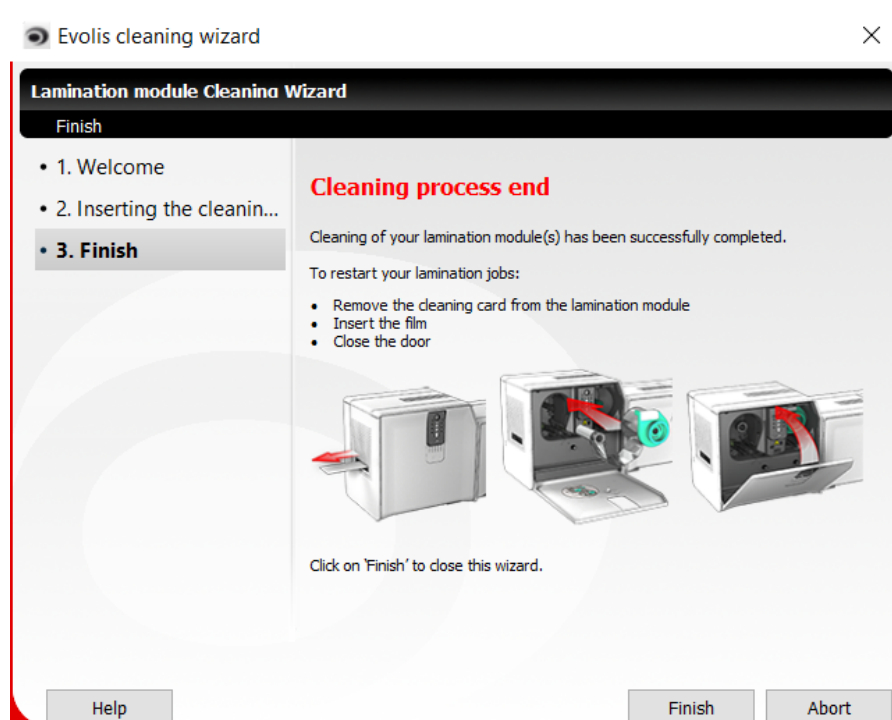

- **In Standalone mode:**

Follow the indications of the **Cleaning** menu and click on **Start Cleaning**.

7.3.4.2.7. Lamination Tools

This option is only available when you have installed the lamination module in the printer-connected mode.

It enables you to laminate cards without printing them before. Cards go through the printer but they are only laminated in the lamination module.

Step 1: Click on **Launch the lamination-only wizard**.

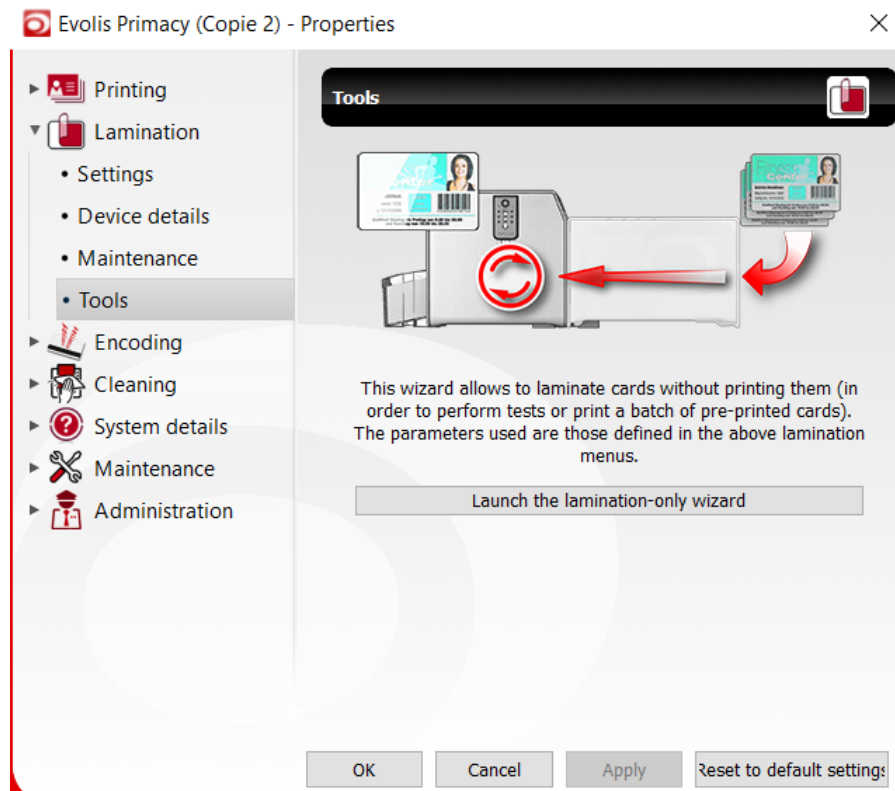

Step 2: Follow the indications of the wizard:

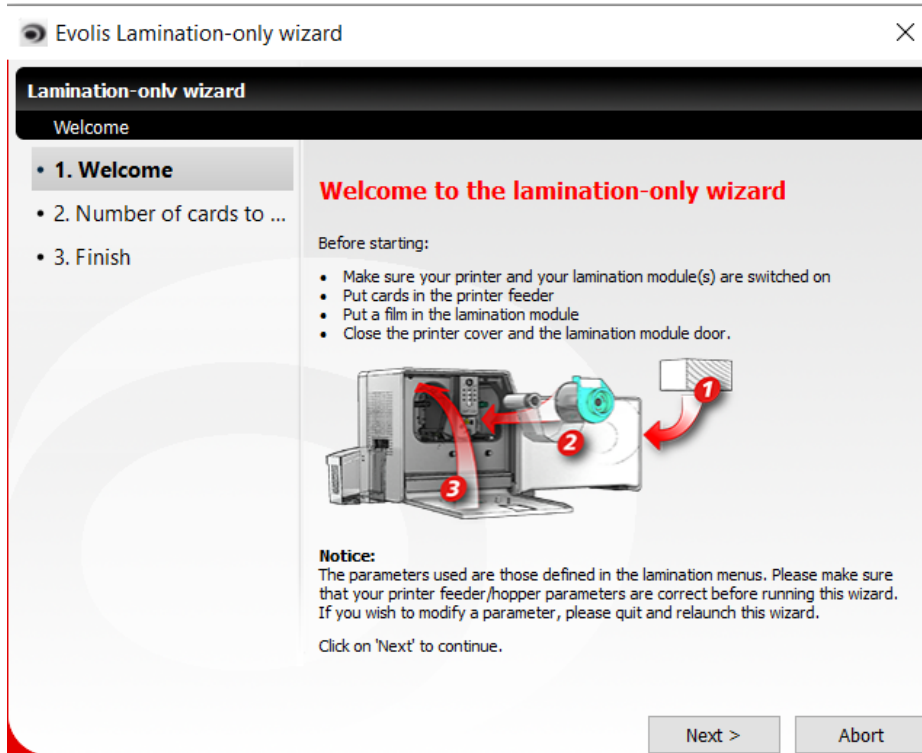

Step 3: Check the [Lamination Settings](#)¹⁰⁸ before starting the wizard. Click on **Next** to launch the wizard.

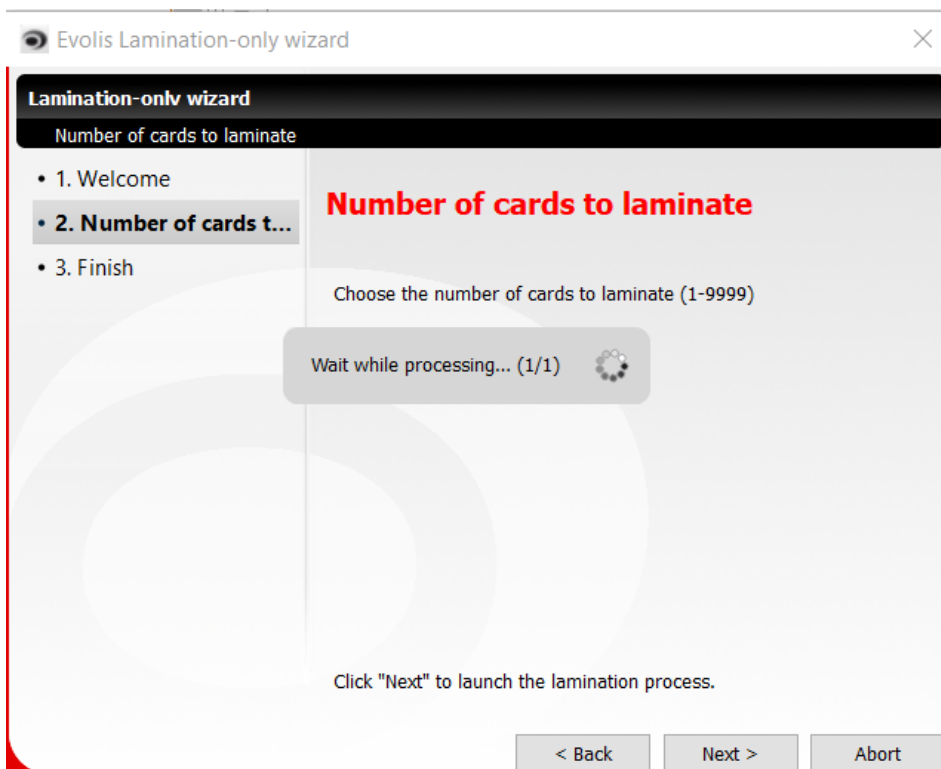

At the end of the lamination process, the laminated card is ejected at the back of the lamination module.

7.3.4.2.8. Standby Mode and Sleep Mode

To save energy, the standby mode of the lamination module can be changed through the Print Center>**Administration**>[Standby Settings](#)  150.

In Standalone mode, go to **Administration**>**Standby settings**.



When **Standby not allowed** is unticked, both the printer and the lamination module will automatically switch to standby mode/sleep mode after the defined period of inactivity.

- To get out of the standby mode:
 - briefly press (for 1 second only) on the printer/lamination module control button,
 - or go to the **Lamination** properties and change some settings,
 - or send a print request
- To get out of the sleep mode:
 1. disconnect the printer and the lamination module
 2. reconnect the lamination module firstly, wait for its pre-heating, then reconnect the printer

7.3.4.3. Encoding

There are three types of encoding systems : magnetic, smart contact and contactless.



Please check that the encoder you wish to use is integrated and well installed in the printer. To check if the adequate encoder is already installed in your printer, go to **Print Center**>**Encoding** and unfold the menu. A sub-menu is dedicated to each encoder in case it was integrated into the printer.

In case you wish to buy and install another encoder, please contact your reseller who will provide you the encoding kit and the associated documentation.

| Type of encoder | Characteristics |
|----------------------------|--|
| Magnetic | <ul style="list-style-type: none"> ○ Driverless ○ Only two models are available: ISO or JIS2 (Japanese standard encoder) |
| Contact Contactless | <ul style="list-style-type: none"> ○ Drivers can be downloaded on www.evolis.com>Drivers and Support>Peripherals and encoders>Encoders>Drivers & firmware. ○ Single or dual encoders are available ○ Visible in Windows>Control Panel>Devices and Printers |

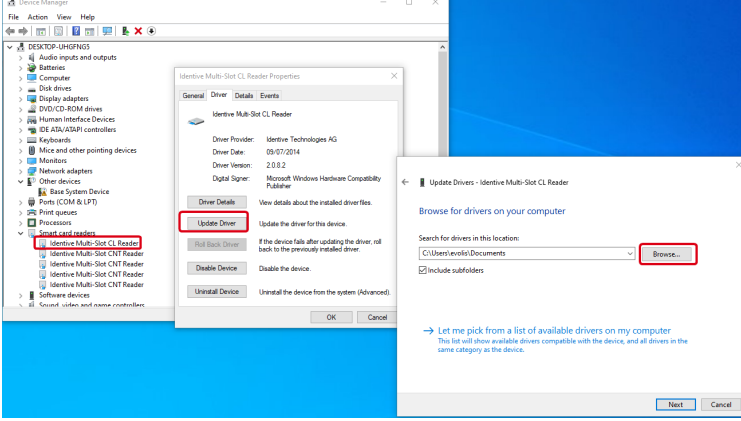
| Type of encoder | Characteristics |
|-----------------|---|
| | <p data-bbox="592 331 699 436"></p> <p data-bbox="703 338 1422 405">Always make sure that you are using the adequate driver for the encoders.</p> <p data-bbox="703 412 1422 517">Automatic updates of your OS may change the default driver. In this case, you will need to define the good driver path for the encoder in Devices and Printers.</p>  |

7.3.4.3.1. Checking the Installation of the Encoding Modules

Two wizards enables to test your encoders installation and their encoding capacity.

From the Print Center, go to **Tools>Magnetic encoding module installation wizard** or **PC/SC encoder checking wizard** 

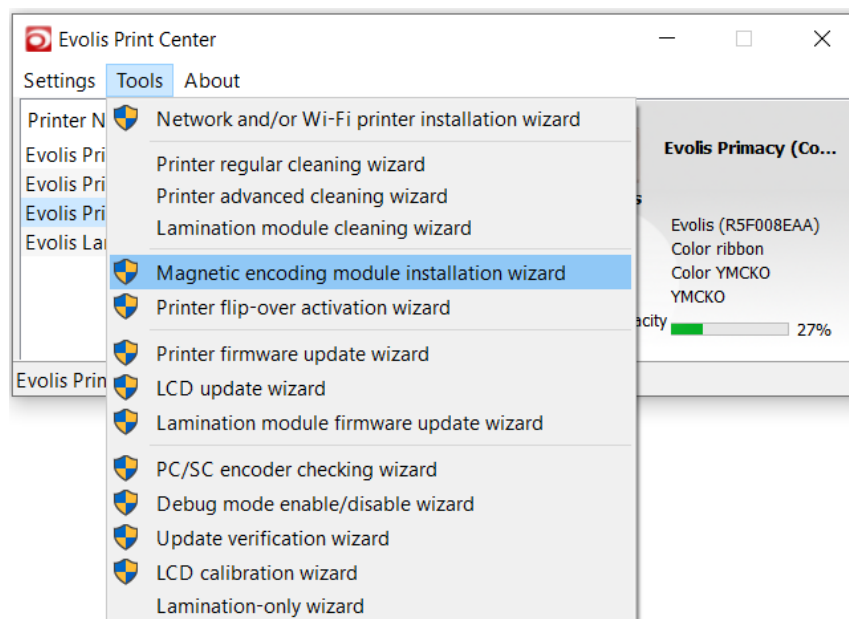

Follow the indications of the wizards:

Magnetic encoding wizard

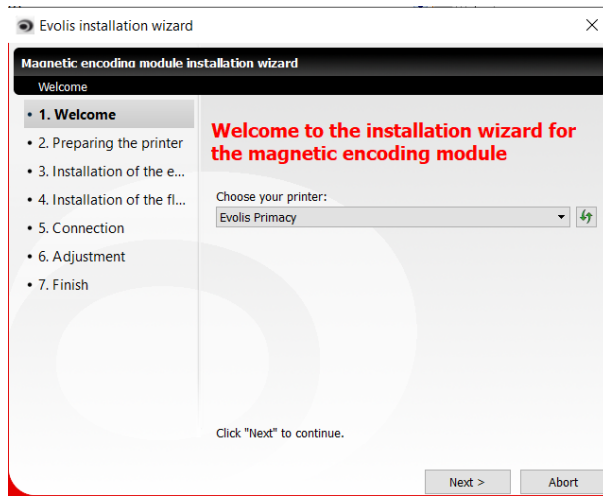

PC/SC encoding wizard (only for encoders connected through USB)

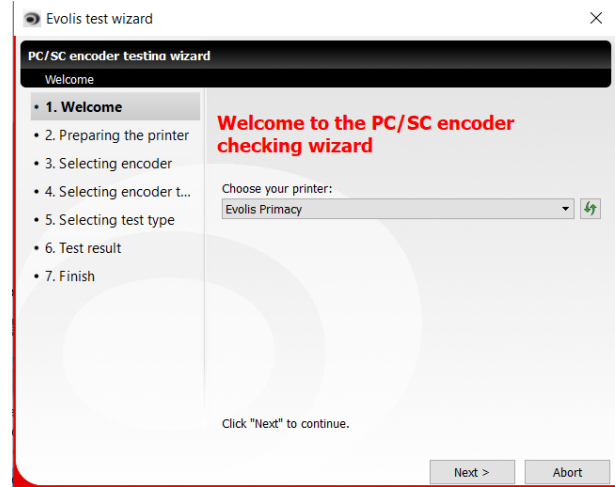

7.3.4.3.2. Magnetic Encoding

Magnetic encoding uses the following support: a magnetic stripe on the card

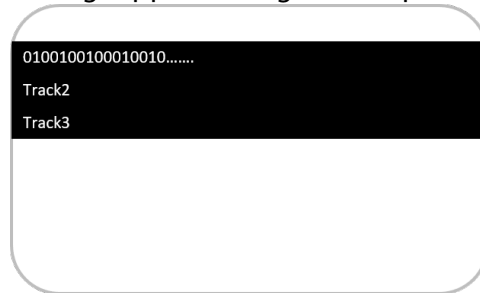

Before starting to encode your card, you need to insert the magnetic card in the printer feeder.

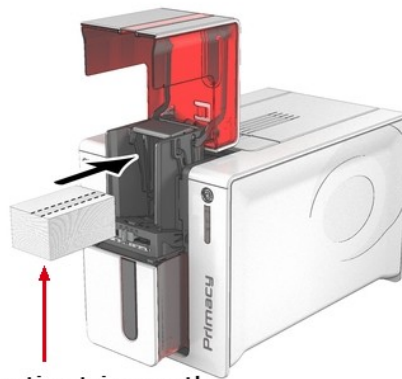

Magnetic stripe on the downside

The first card to be encoded is the one that is at the bottom of the cards stack.

7.3.4.3.2.1. Checking the Installation of the Magnetic Encoder

Step 1: From the Print Center, check the adequate installation of the encoder through **Tools>Magnetic encoding module installation wizard** or **Maintenance>Installable Options**. Follow the instructions of the wizard.

Step 2: If the test on adjustment is not successful, please try again with the card inserted as indicated on the picture in the wizard.



If the test is still not successful, please reinstall the encoder. Finally, you may contact the [Support](#) team.

7.3.4.3.2.2. Setting the Encoding Properties

Step 1: To access the Print Center encoding properties, click on **Encoding>Magnetic**.

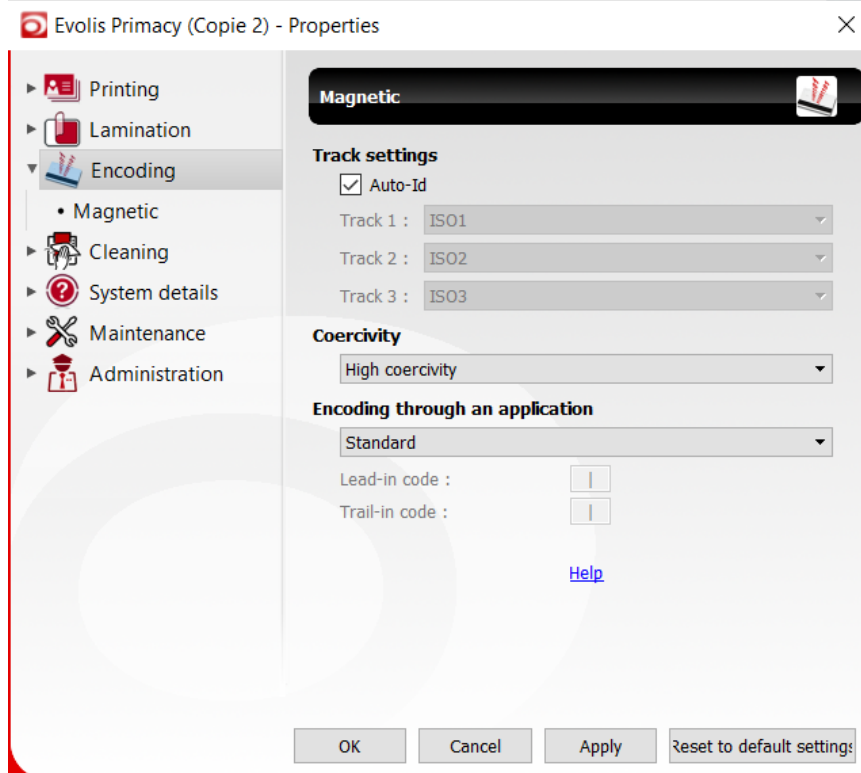

Step 2: Change the settings as explained in sections [Track Settings](#)^[126], [Coercivity](#)^[128] and [Encoding Through an Application](#)^[128].



Make sure **not to apply** an overlay  on the magnetic stripe. If the overlay is applied on the magnetic stripe, the reading of the encoded information may not be well performed. To apply an overlay of custom bitmap file on the card (with no overlay on the magnetic stripe), please refer to section [Front Side Varnish Adjustment](#)^[90]. Before starting the encoding of a card side, always check the parameter that was selected in **Varnish type**: "no varnish" or "custom bitmap" are correct options whereas "**full varnish**" is not a good option.

Step 3: Go to the application you use to print the encoded areas (for more details, refer to sections [Using Word](#)^[130], [Using Cardpresso](#)^[131] and [Using Your In-House Application](#)^[137]). You can use any other software that is able to detect text areas and non-text areas (Notepad, for instance).

Untick **Auto-Id** if you want to change the encoding standard for each track.

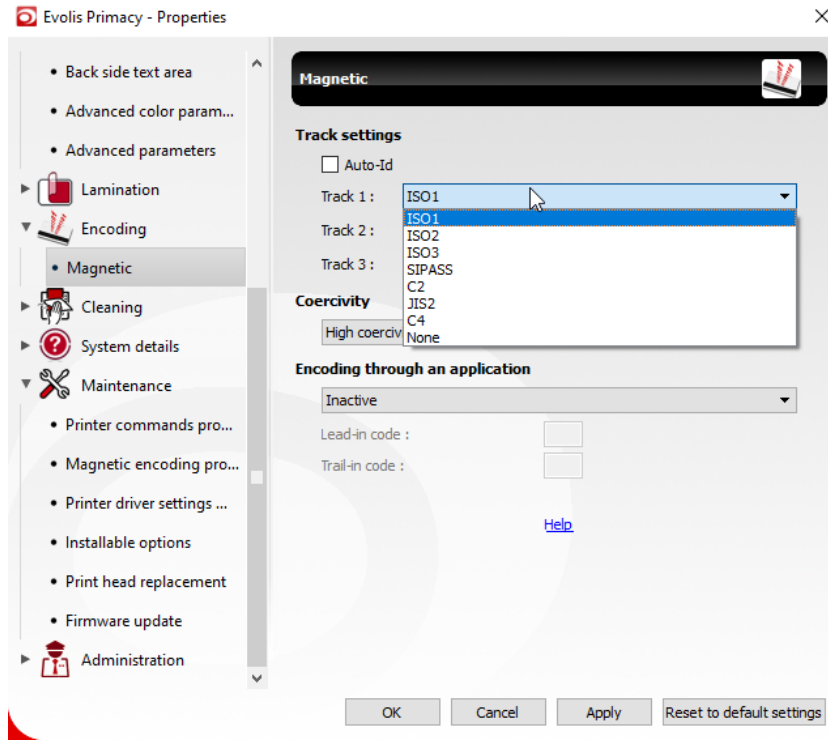

The stripes can be configured in ISO, SIPASS, C2, JIS2 and C4 format. See the tables below for information on the ISO 7811 and JIS2 (Japanese Industrial Standard) standards.

ISO 7811 magnetic encoding standards

| Stripe # | Separator | Density | Character set | Number of characters |
|------------------|-----------|-------------------------|----------------------------|----------------------|
| Stripe #1 | ^ | 210 bpi (bits per inch) | Alphanumeric (ASCII 32-95) | 79 |
| Stripe #2 | = | 75 bpi | Numeric (ASCII 48-62) | 40 |
| Stripe #3 | = | 210 bpi | Numeric (ASCII 48-62) | 107 |

ISO1 accepts up to 793 alphanumeric characters, from A to Z and from 0 to 9 along with ASCII characters between 32 and 95.

ISO2 accepts up to 403 numeric characters, from 0 to 9 along with ASCII characters between 48 and 62.

ISO3 accepts up to 1073 numeric characters, from 0 to 9 along with ASCII characters between 48 and 62.



Character set: The "?" character cannot be used

Number of characters: Including the Start, Stop and LRC characters (automatically handled by the magnetic encoder)

JIS2 magnetic encoding standards

| Stripe # | Separator | Density | Character set | Number of characters |
|-----------|-----------|---------|-------------------------------|----------------------|
| Stripe #1 | ^ | 210 bpi | Alphanumeric (ASCII 32-95) | 79 |

The C2 and C4 configurations relate to custom mode and are reserved for future use.
The SIPASS configuration accepts 21 characters, from 16 to 127 (ASCII characters).

Two types of coercivity are available for the magnetic stripe.

With Evolis cards, the following types are available:

| Type of coercivity | Meaning |
|------------------------|---------------------|
| Hico (high coercivity) | high immunity level |
| Loco (low coercivity) | low immunity level |

| Option | Meaning |
|--------------------------------------|---|
| Inactive | Enables encoding and reading to be performed through the driver properties only. Please refer to section Encoding Through the Print Center ¹²⁸ for more details. |
| Standard (set by default) | Enables encoding to be performed from an adequate application (i.e. Cardpresso, Word, Notepad...). The adequate applications can distinguish between text areas and non-text areas.  PDF documents cannot be used for editing your cards with encoded text areas. By default, the lead-in and trail-in code is: (AltGr+6 on Windows keyboard) |
| Customized | Enables to change the lead-in and trail-in codes |

7.3.4.3.2.3. Encoding Through the Print Center



Step 1: Insert the magnetic card in the printer feeder ( magnetic stripe on the down-side and on the right of the printer).

Step 2: From the Print Center **Properties**, click on **Encoding>Magnetic**.

Step 3: Go to field **Encoding through an application** and select **Inactive**.

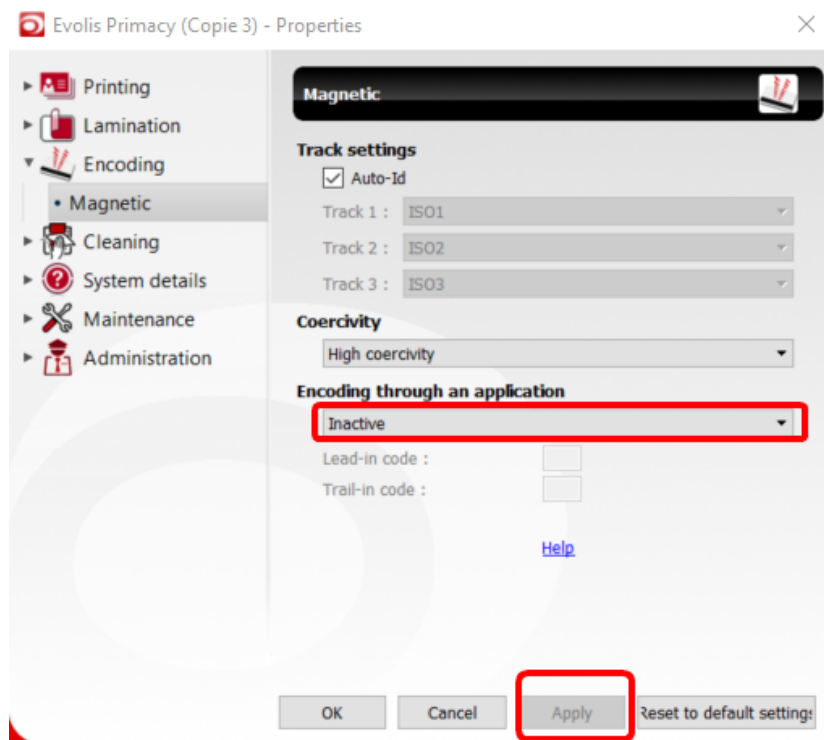

Click on **Apply**.

Step 4: Go to **Maintenance**>**Magnetic Encoding Prompting**.

Tick the track you want to edit, enter the values and click on **Encode tracks**.

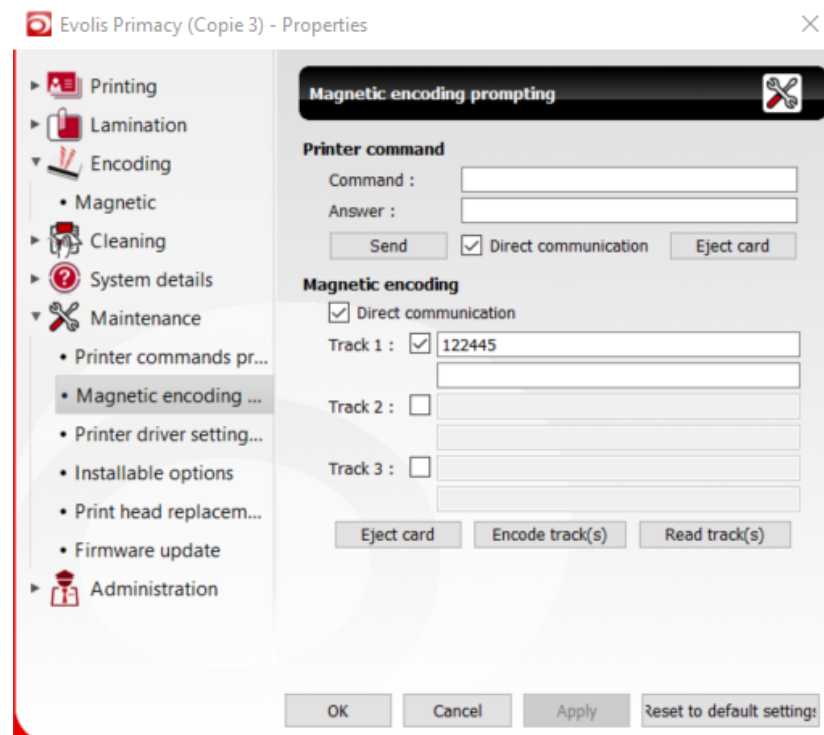

The encoding process is started. You can read (**Read tracks**) or rewrite the tracks (**Encode tracks**) as needed.

For the explanation on **Printer command** section, please refer to section [Magnetic Encoding Prompting](#)¹⁴⁵.

7.3.4.3.2.4. Encoding Using Word



Step 1: Insert the magnetic card in the printer feeder (magnetic stripe on the down-side and on the right of the printer).

Step 2: From the Print Center **Properties>Encoding>Magnetic**, keep the **Standard** selection in the field named **Encoding through an application**. Click on **Apply**.



If the **Standard** option is not selected, the encoding through Cardpresso software is not possible.

Step 3: From the Word document, go to Print and select the printer you want to work with.

Step 4: Go to page setup.

- Set the size on CR80 format.
- Set the margins on 0.1 mm as a minimum.

Step 5: Edit your Word document.



For the encoded lines, do not forget to use the lead-in code followed by the track number at the beginning, and the trail-in code at the end.

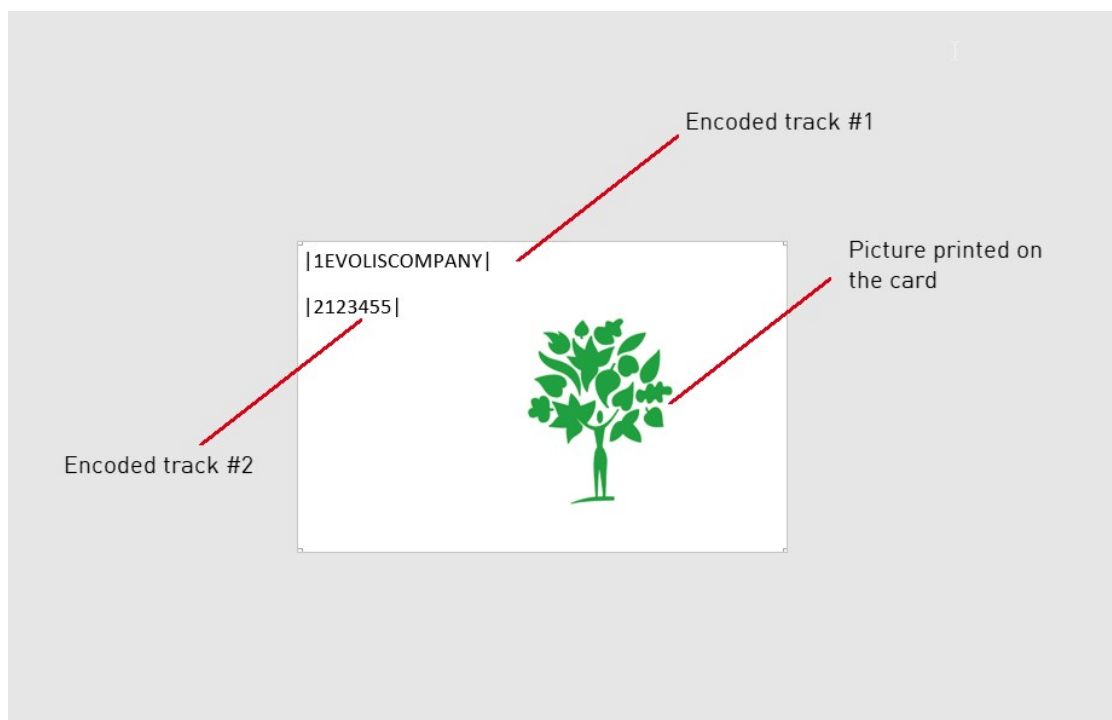



Never save the Word document in the .pdf format before starting the encoding process. The printing job would be performed without taking into account the encoded data.

7.3.4.3.2.5. Encoding Using Cardpresso



Step 1: Insert the magnetic card in the printer feeder (magnetic stripe on the down-side and on the right of the printer).

Step 2: From the Print Center **Properties>Encoding>Magnetic**, keep the **Standard** selection in the field named **Encoding through an application**. Click on **Apply**.



If the **Standard** option is not selected, the encoding through Cardpresso software is not possible.

Step 3: From Cardpresso, select the adequate type of magnetic card. Magnetic encoding is available from XXS version of Cardpresso software.

Step 4: From the card designing window, click on the **View card back** button to display the encoding tracks.

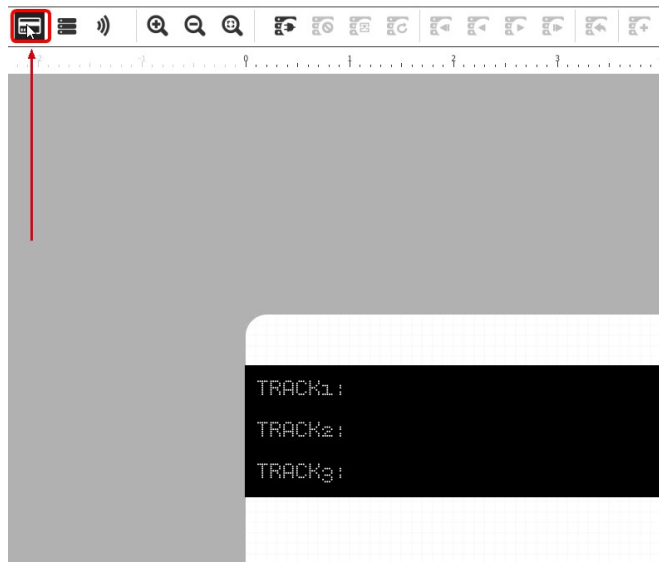

Step 5: Click one of the tracks to enter the content.

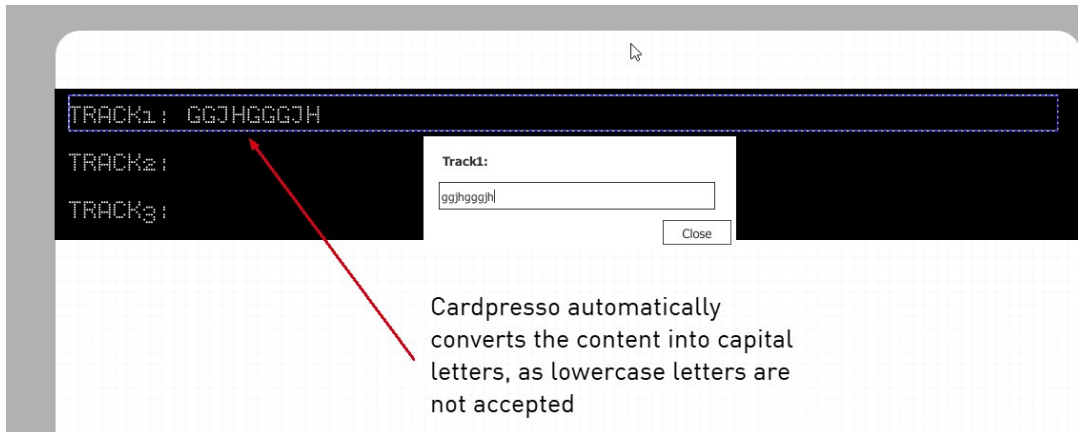

Step 6: From the right part of Cardpresso software, you can change the source of your track content, then match your database content with each track.

| |
|--------|
| Item |
| Font |
| Source |

| |
|----------------|
| Keyboard Input |
| Print Counter |
| Print Date |
| Keyboard Input |
| Database |
| Item Link |

When Item Double-Clicked

Save with document

No

Data Type

Text Line

Font auto adjust

Never

Concatenation



For more details, please refer to the help available in the application.

Step 7: To print the encoded card, go to **File>Print** and select **Magnetic Encoding**.

Step 8: To read the tracks you have just encoded, go to the **Print Center>Maintenance>Magnetic Encoding Prompting**.

Select the tracks and click on **Read track(s)**.

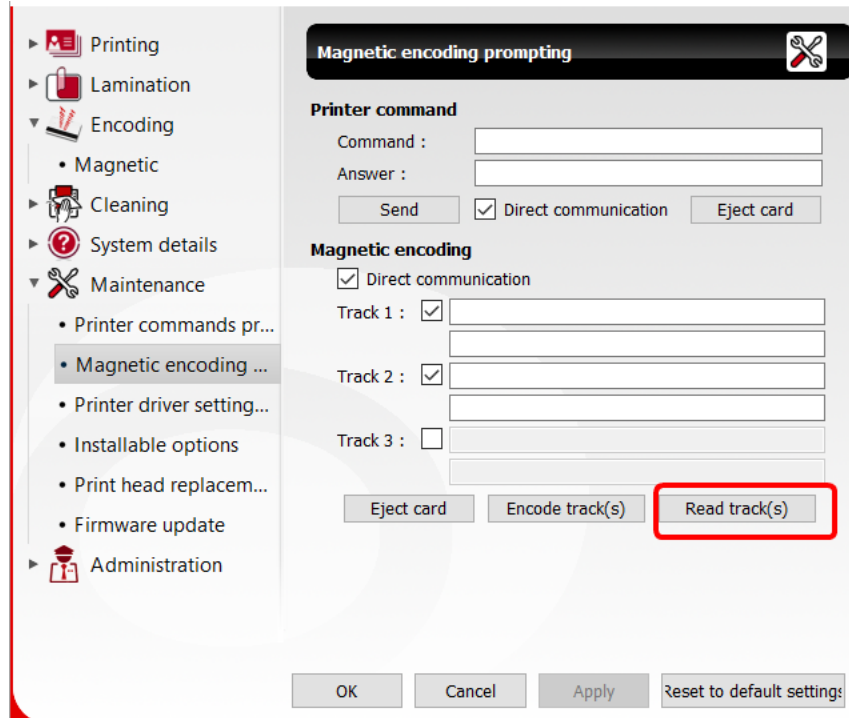

7.3.4.3.3. Contact/Contactless Encoding

Contact encoding  is also called "smart contact". The encoded data in the integrated chip are read through a contact reader.

Contactless  encoded data are read through a RFID reader.

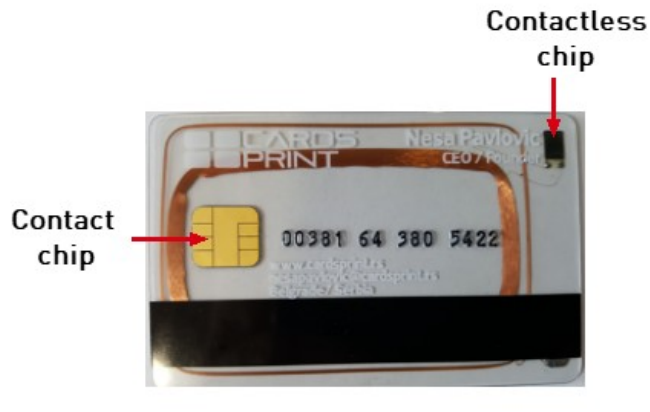

A "smart" or contact card is CR80 card with an integrated circuit (CPU, memory...)

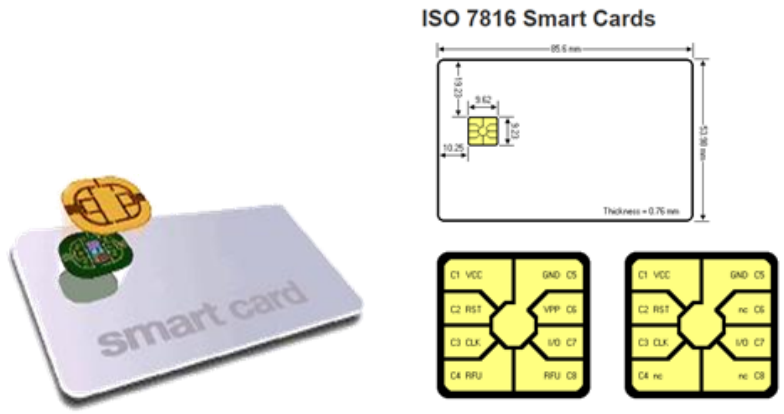

A contactless card is CR80 card with integrated chip and antenna.

The encoder (coupler) is always integrated inside the printer. The communication is performed through microwave frequencies.

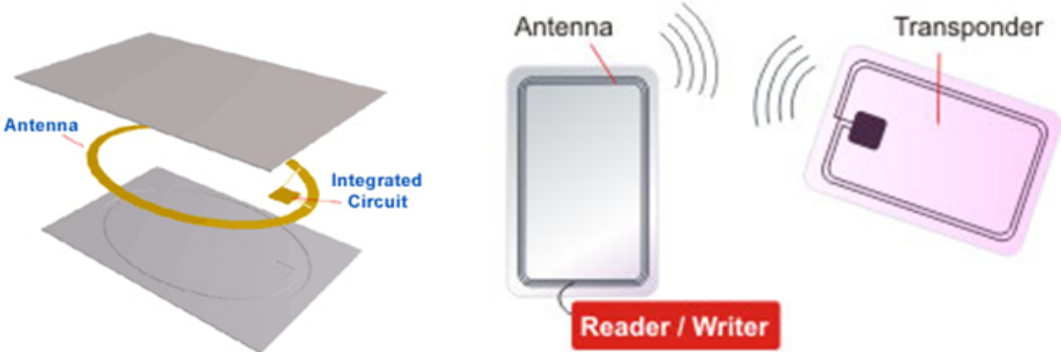

7.3.4.3.3.1. Assigning the Adequate Driver for Your Encoder

Step 1: Go to www.evolis.com>Drivers&Support>Drivers&Firmware.
Then select the driver and click on **Download**.

evolIS Markets ▾ Products & Services ▾ Case studies

Smart Contact

| Coupler | Link to SDK / Drivers / Tools |
|----------------------|-------------------------------|
| EVOLIS ELYCTIS SMART | Download |

Smart Contactless

| Coupler | Link to SDK / Drivers / Tools |
|-------------------------------|-------------------------------|
| EVOLIS ELATEC TWN4 LEGIC@ NFC | Download |
| CAEN RFID UHF R1230CB | Download |
| SPRINGCARD CRAZY WRITER HSP | Download |

Dual (Smart Contact & Smart Contactless)

| Coupler | Link to SDK / Drivers / Tools |
|----------------------------|-------------------------------|
| EVOLIS ELYCTIS DUAL (v2.0) | Download |
| OMNIKEY 5122 | Download |

Step 2: To assign the adequate driver to the encoder, go to **Devices Manager>Smart Card Readers**

Right-click on the reader.

Click on **Update Driver>Browse my computer for driver software** (browse the files that you downloaded before).

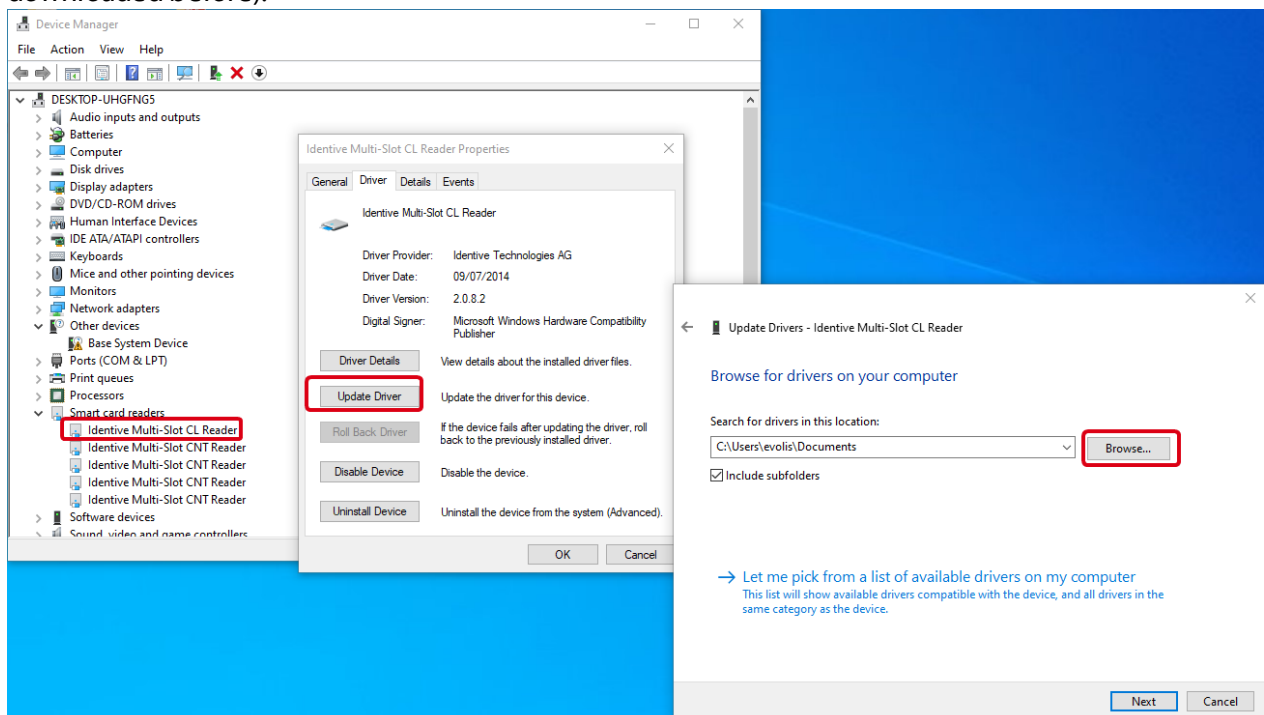

7.3.4.3.3.2. Checking the Installation of the PC/SC Encoder

Step 1: Before installing the encoder, it is necessary to download the corresponding driver. The purpose is to avoid Windows OS updates to install automatically an inadequate driver.

Go to **www.evolis.com>Drivers&Support>Drivers&Firmware**. Then select the adequate driver and click on **Download**.

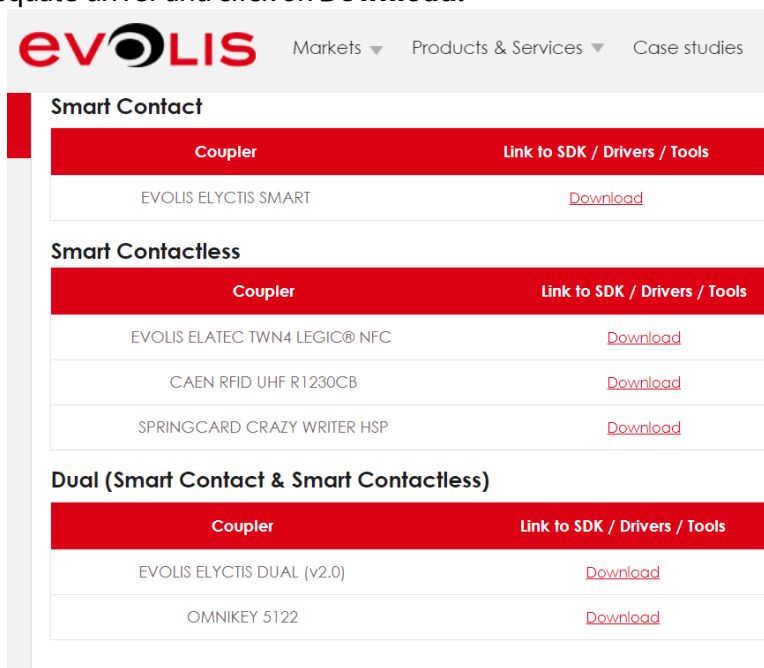

The screenshot shows the Evolis website's driver download page. It is organized into three main sections: Smart Contact, Smart Contactless, and Dual (Smart Contact & Smart Contactless). Each section has a red header bar with 'Coupler' and 'Link to SDK / Drivers / Tools'. Below each header is a table of driver models with 'Download' links.

| Smart Contact | |
|----------------------|-------------------------------|
| Coupler | Link to SDK / Drivers / Tools |
| EVOLIS ELYCTIS SMART | Download |

| Smart Contactless | |
|-------------------------------|-------------------------------|
| Coupler | Link to SDK / Drivers / Tools |
| EVOLIS ELATEC TWN4 LEGIC@ NFC | Download |
| CAEN RFID UHF R1230CB | Download |
| SPRINGCARD CRAZY WRITER HSP | Download |

| Dual (Smart Contact & Smart Contactless) | |
|--|-------------------------------|
| Coupler | Link to SDK / Drivers / Tools |
| EVOLIS ELYCTIS DUAL (v2.0) | Download |
| OMNIKEY 5122 | Download |

Step 2: Install the driver according to the instructions provided by your reseller (Encoding Kit and other guides).

Step 3: From the Print Center, check the adequate installation of the encoder through **Tools>PC/SC encoder testing wizard**. Follow the instructions of the wizard.



1. Only encoders connected through the USB port can be tested.
2. Do not forget to insert an adequate test card in the printer.

=> If a numbering value appears in the field **number of reads OK** and no value appears in the field **number of reads failed**, then the test is positive (the ATR code was successfully read). If the result is the opposite, then the test is negative. In this case, please check that your encoder is well installed. Also check that the adequate driver is installed (for more details, go to section [Installing the Adequate Driver for Your Encoder](#))¹³⁴.

7.3.4.3.3.3. Contact/Contactless Using Cardpresso

Cardpresso encoding management is explained in detail in the embedded **Help** of the software.

7.3.4.4. Developing Your In-House Encoding Application

For indications and help on how to develop your in-house encoding application, please rely on the SDK or Premium SDK toolkit.

For more information, please contact your Evolis reseller or the [Support](#) team.

7.3.4.5. Cleaning

The cleaning cycles must be performed when requested by the printer (warning light flashing or steady) in order to:

- respect the warranty conditions
- increase the life of the print head
- prevent feeding/printing issue due to the environment

To know about the cleaning cycles of your printer, please refer to the User Guide of the printer.

7.3.4.5.1. Cleaning Details



This window is only available in **Standard** or **Supervision** modes.

Information is provided about the cleanings that must be performed and the ones that have already been performed.

Click on **Refresh** if necessary.

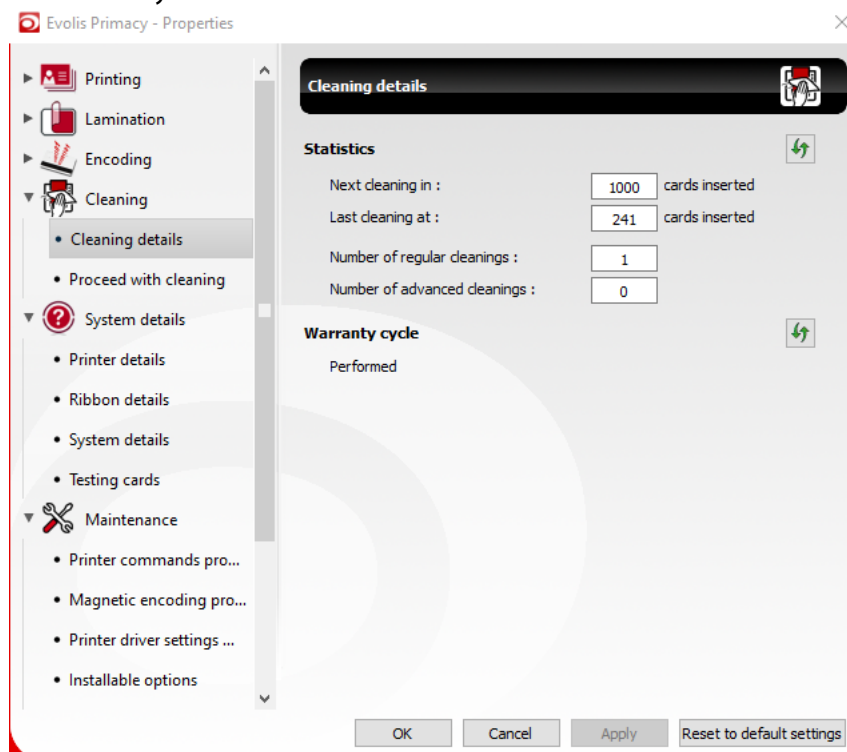

If you need to perform a cleaning cycle, go to next section.

7.3.4.5.2. Proceed With Cleaning

This window enables to start [regular](#)¹³⁸ or [advanced](#)¹⁴⁰ cleaning.



7.3.4.5.2.1. Proceed With Regular Cleaning

Click on **Regular Cleaning**>**Start Cleaning** and follow the instructions of the wizard and the LED or LCD  panel (if available).



Follow the first steps to prepare the printer :

- Remove all cards from the feeder
- Remove the ribbon from the printer
- Adjust the gauge to max. position
- Close the cover
- Prepare an adhesive card

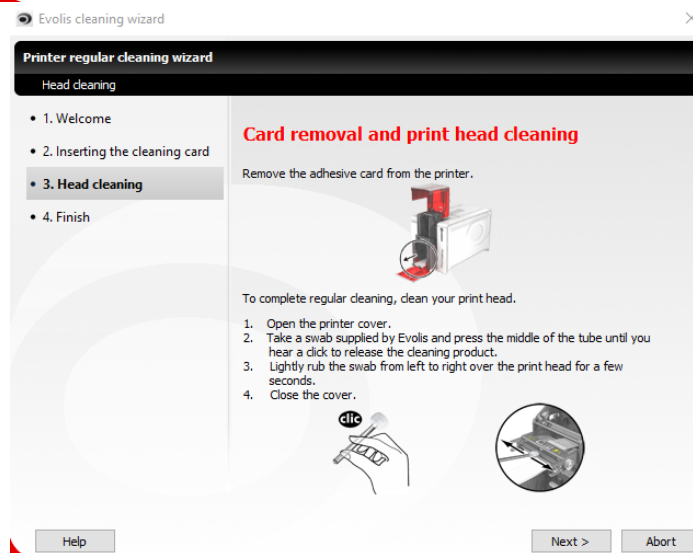
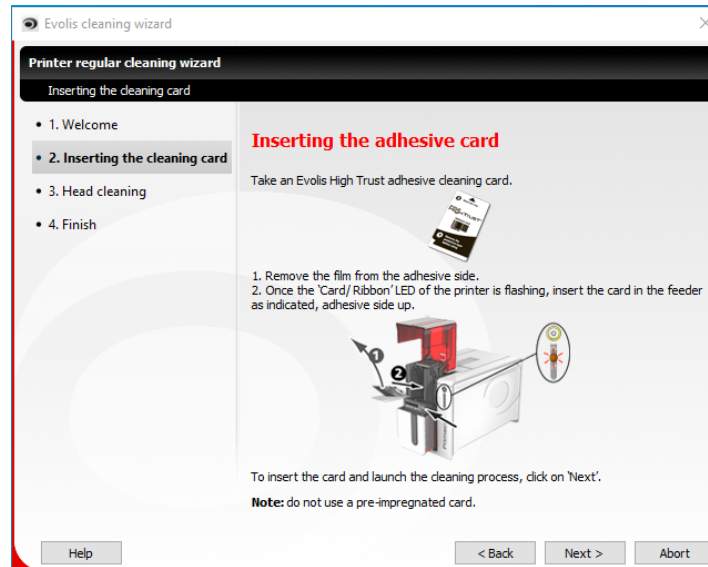

Do not forget to prepare the printer to the printing process, as described in the last step:

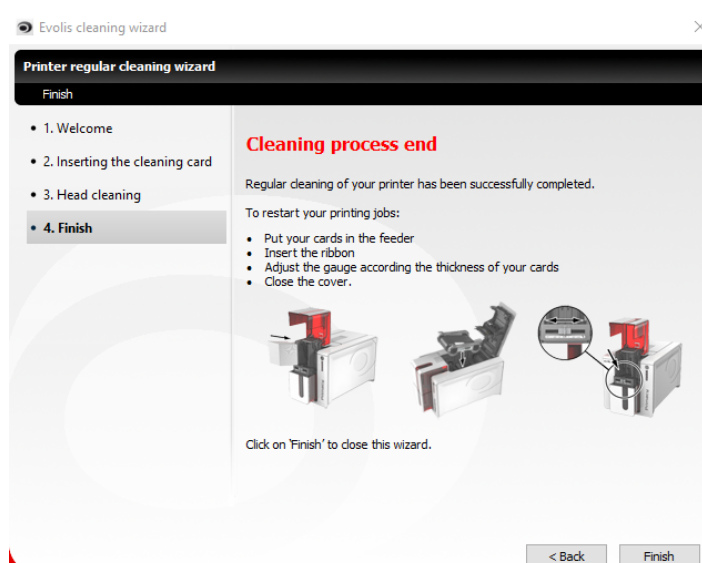

7.3.4.5.2.2. Proceed With Advanced Cleaning

Click on **Regular Cleaning** > **Start Cleaning** and follow the instructions of the wizard and the LED or LCD  panel (if available).



Follow the first steps to prepare the printer to the cleaning process :

- Remove all cards from the feeder
- Remove the ribbon from the printer
- Adjust the gauge to max. position
- Close the cover
- Prepare a T" card as well as an adhesive card

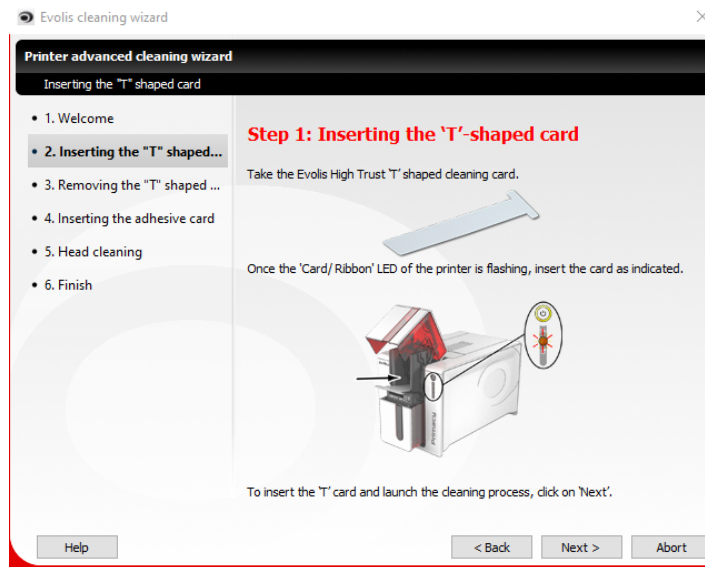

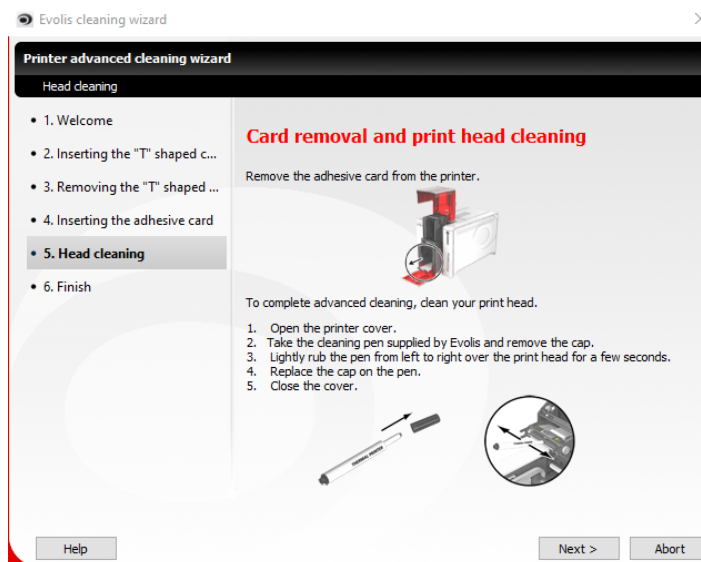

Do not forget to prepare the printer to the printing process, as described in the last step:

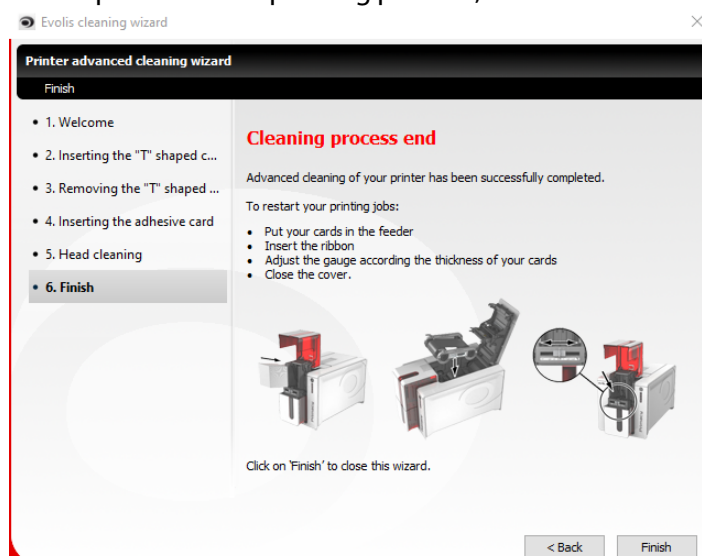

7.3.4.6. System Details

This window provides essential information about the printer and its modules.

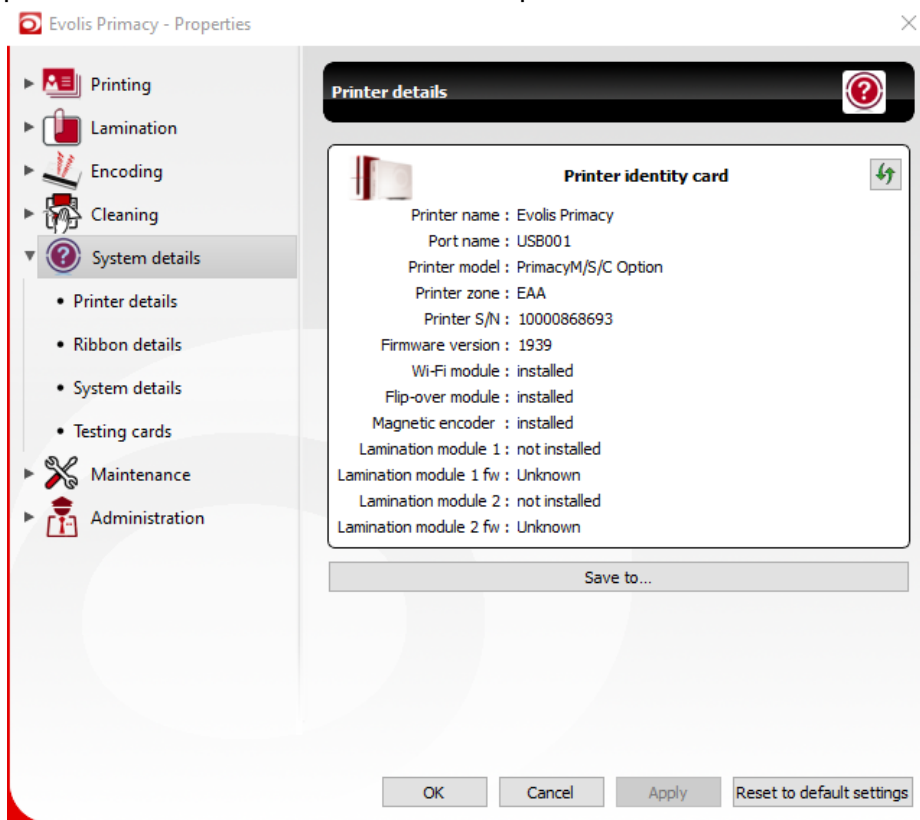

Click on **Save** to if you want to store the information in a .txt file.

The file created also includes detailed information about the printer:

- version numbers of the different modules,
- network information,
- printing and cleaning settings,
- ribbon details.



Please send this file to the [Support](#) team in case you encounter an issue.

Installed products:
Setup 6.32.3.1481
Print Center Service version 2.25.3.530
ESPF version 1.7.4.188
Print Center User Interface version 2.21.0.267
Printer Manager version 2.13.3.111
Driver version 3.0.7.881
Language Monitor version 2.15.1.103
User Interface version 1.18.1.255
IOMem version 5.12.20.98
EvoBase version 3.19.1.226
EvoMcl version 3.19.1.226
EvoSetting version 3.19.1.226

Computer Name:
Operating System: Microsoft Windows 10 Enterprise Edition (build 18362), 64-bit

Printer identity card

Printer name: Evolis Primacy
Port name: USB001
Printer model: PrimacyM/S/C Option
Printer zone: EAA
Printer S/N: 10000868693
Firmware version: 1939
Printer rpws: 1293725893
Wi-Fi module: installed
Flip-over module: installed
Magnetic encoder : installed
Lamination module 1: not installed
Lamination module 2: not installed
Kineclipse® option: not installed

Hostname: EVO_PR1_0868693
IP address: 192.168.1.17
Mac address: 00-1A-FD-0D-41-55
Multicast: 224.69.86.79
DHCP: Disabled
Subnet mask: 255.255.255.0
Gateway: 192.168.1.254
WINS server: 0.0.0.0
Ping result:

-
Wi-Fi settings: RP0;"ODIN-W2" RP1;"6.0.0-050" RP5;"0233965903274997"

Flip-over act. Key S/N:
Flip-over act. Source: PR
Flip-over: CF1120X80697 3f59ccacaaa6cc5751b54f76d0d228a5

Color act. Source: DISABLE

Print head kit n° 1: 285-EB803334
X-Y-Smart offsets: 233 - 9 - 415
Printed Lines L/W: 997L / 636W
Inserted cards : 241 G:241
Cleaning cycles H: 3 / 231
Cleaning cycles G: 3 / 231

Ribbon details

Ribbon capacity: 200
Ribbon code: R5F002EAA
Category: Color ribbon
Type: YMCKO
Remaining capacity: 85 %
Internal code: C0000141
S/N: 0000002008031430
Lot Number: 5431703
Description: Color YMCKO

Click on each tab to display the details associated : Printer, Ribbon, System.

7.3.4.6.1. Testing Cards

This window enables you to create two types of cards: graphical test card (printing quality) and technical test card (also called "St card").

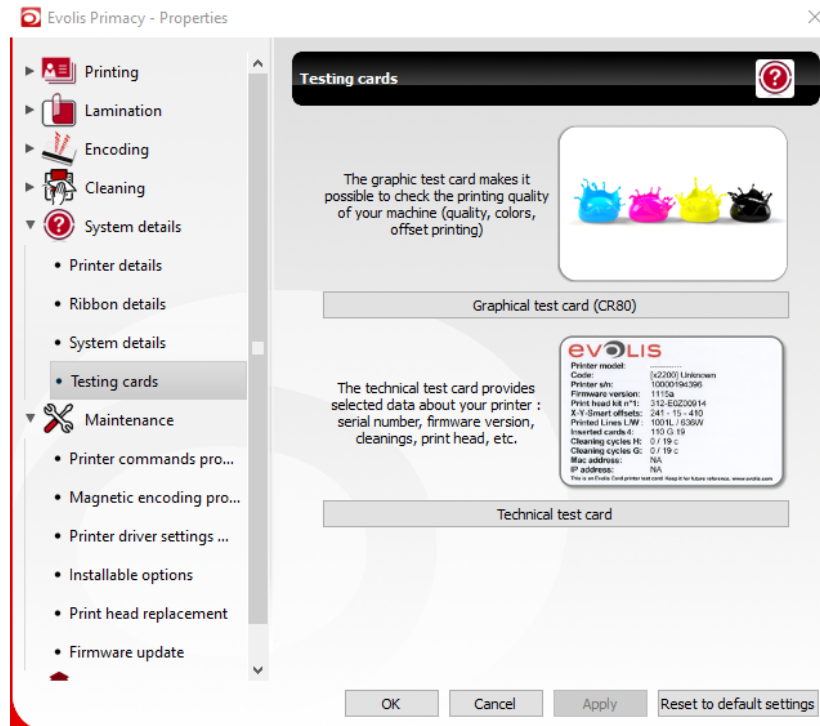

NOTE Please send the technical test card file to the [Support](#) team in case you encounter an issue.

If the result of the test is not satisfying in one or the other test card, please refer to section [Troubleshooting: Printing Issues](#) ¹⁵³.

7.3.4.7. Maintenance

These tabs help the user to perform the the first maintenance tasks of the printer.

7.3.4.7.1. Printer Commands Prompting

R means **Reading**

P means **Programming**

Some examples of commands:

| Command | Meaning | Good answer |
|------------|-------------------------|--|
| Rfv | Read Firmware Version | Firmware number is displayed |
| Rip | Read IP Address | IP address of the printer is displayed |
| Stt | Sequence Technical Card | The card is printed and ejected. The answer must be OK. |

| Command | Meaning | Good answer |
|----------------------------------|-------------------------------------|---|
| Pip;192.168.0.1 (example) | Program the IP address | The new IP address is configured and the answer must be OK . |
| Rflo | Read the status of flip-over module | ENABLE => the module is active DISABLE => the module is not active |
| Sa | Sensors adjustment | The sensors adjustment is checked. The answer must be OK . |

TROUBLESHOOTING - Possible wrong answers are:

ERROR CDE => please check the command

Unable to communicate with printer => please check that connection cable is well plugged both on the computer and the printer

7.3.4.7.2. Magnetic Encoding Prompting

This window is used to send commands and test the tracks for magnetic encoding:

- through commands (1. **Printer Command** paragraph)
- through the buttons (2. **Magnetic encoding section** paragraph)

1. Printer Command

Useful commands are the following:

| Command | Meaning | Good answer |
|--|---|--|
| Smr | Inserts the card into the printer, so that it is ready to be read or encoded by the magnetic encoding module | OK The card is inserted at the adequate position |
| Smr;1 Smr;2 Smr;3 | Reads the data encoded in each track (1,2,3) | Corresponding data is displayed |
| Dm;1;data Dm;2;data Dm;3;data | Sends the data that needs to be encoded in each track (1,2,3) | OK |
| Smw | Launches and performs the encoding process The card is not ejected. Click on Eject card if necessary. | OK |
| Rmc | Reads the coercivity type | high co low co |
| Pmc;l Pmc;h | Sets the coercivity type (l for low coercivity; h for high coercivity) | OK |
| |  Please check that the card you are using is adapted to the coercivity level set here. | |



The most common commands can be also performed by the magnetic encoding section menu. See next paragraph.

2. **Magnetic encoding section:** go to section [Encoding Through the Print Center](#)^[128] for more information on how to use the settings.

TROUBLESHOOTING - Possible wrong answers are:

ERROR PARAMETRES => please check the command and correct it

Unable to communicate with printer => please check that connection cable is well plugged both on the computer and the printer

ERROR MAGN DATA => please check the data sent to the encoding module: it is not adequate with the standard set in the Track Settings (see section [Setting the Encoding Properties](#))^[126]

ERROR MAGN => please check that your card was inserted in the feeder as explained in section [Magnetic Encoding](#)^[125]

ERR READ MAGNETIC/ERR WRITE MAGNETIC/ERROR BLANK TRACK => Check the installation of the encoding module in the printer. Go to section [Checking the Installation of the Magnetic Encoder](#)^[125].

7.3.4.7.3. Printer Driver Settings

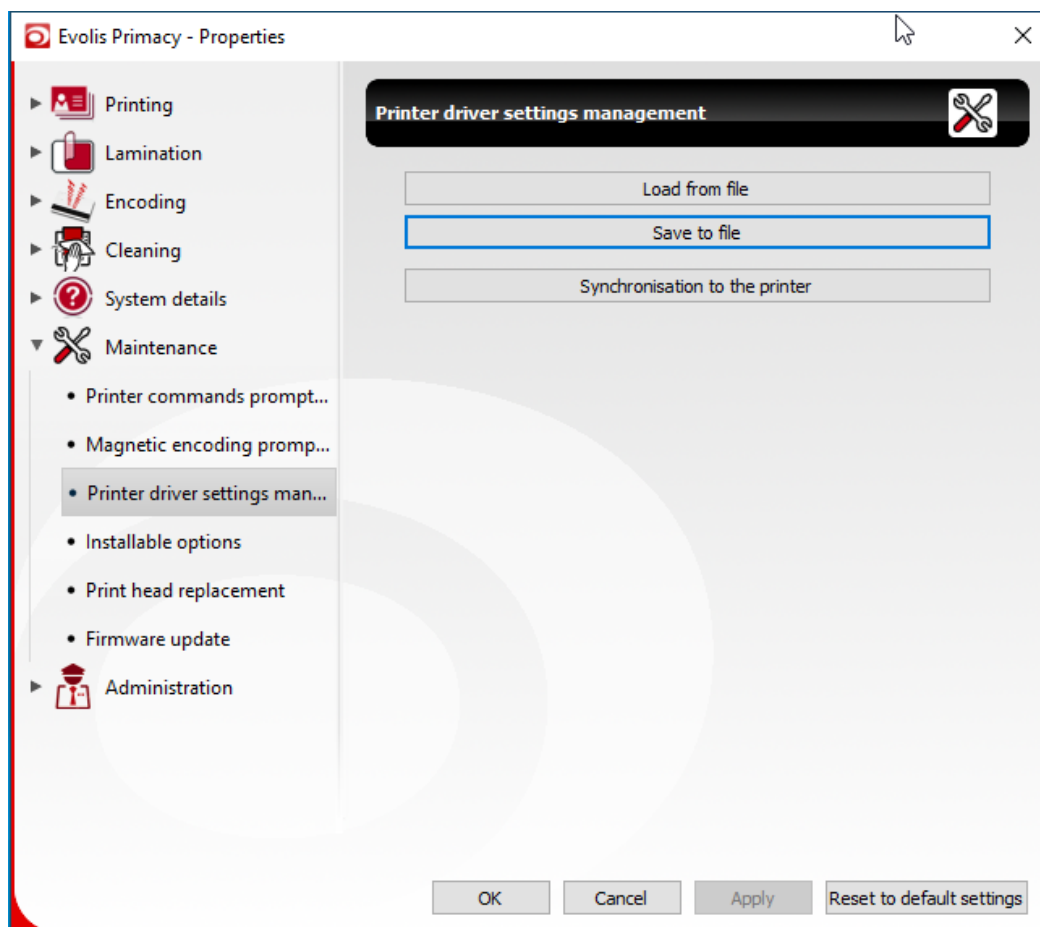

Step 1: Click on **Save to file** if you want to save the current driver parameters in a **.dat** file.

This file is useful if you want to reuse the same configuration on one or many other machines, without having to reset manually all parameters.
It may also be useful in case of troubleshooting by the customer [Support](#) team.

Step 2: From another computer, click on Load from file to import the .dat file, then click on **Apply**. All printing jobs will have the new settings applied.

Synchronisation to the printer is used to stored the settings in the printer itself. This feature is useful for SDK purposes (for more details, please contact your reseller contact or Evolis [Support](#) team).

7.3.4.7.4. Print Head Replacement

Use this tab when you want to replace the print head.

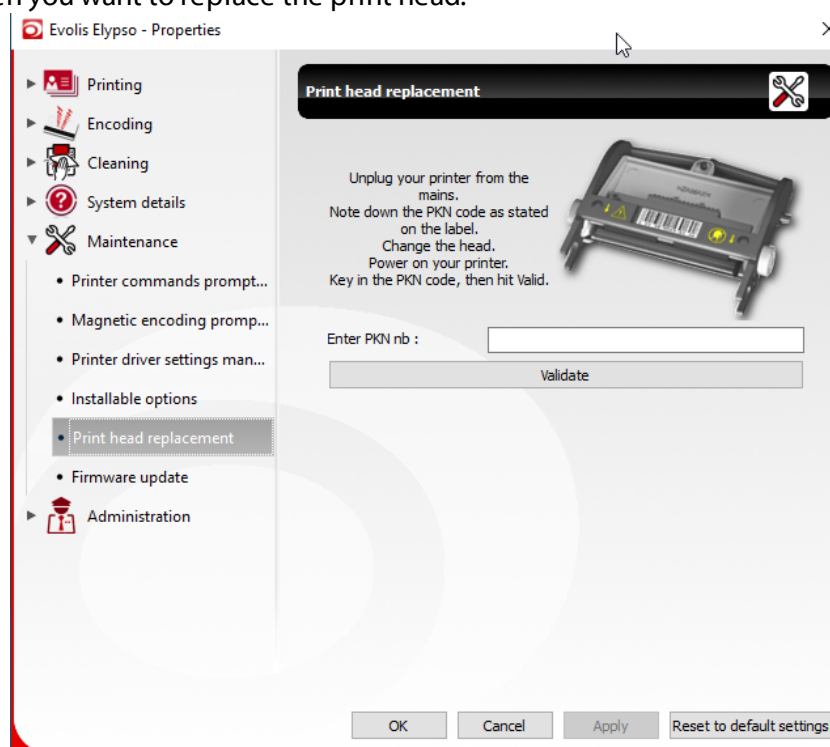

All useful indications are written on this tab.

NOTE As a reminder, changing the print head is necessary when the current one is defective.

Step 1: Unplug the printer.

Step 2: Replace the print head as indicated in the **Service Manual** dedicated to your printer.

Step 3: Enter the PKN number (check the images below to find the PKN number) and click on **Validate**.



The printer status changes and a notification indicates the need to perform a regular cleaning.



Step 4: Click on **OK** or **Cancel** and go to the regular cleaning wizard. For more details, see section [Proceed With Regular Cleaning](#)¹³⁸.

Step 5: Once the cleaning has been performed, the printer status in the Print Center is **Ready**. You can use the printer.

7.3.4.7.5. Firmware Update

Step 1: Go to www.evolis.com and make sure you download the firmware file (.firm) that is adequate for your printer.

Step 2: From the Print Center or Evolis Printer Properties, go to **Maintenance**>**Firmware update** and follow the wizard instructions.

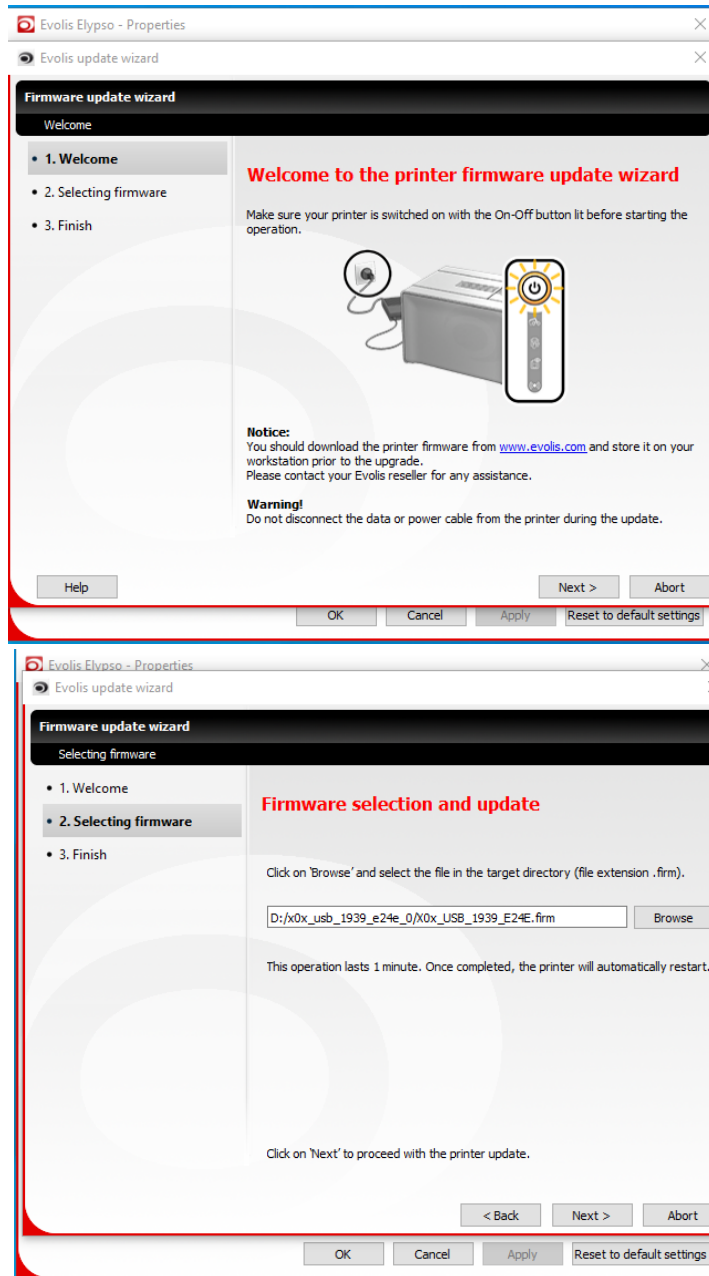

During the update process, the light of the printer switch on/off button is blinking. Then a synchronization is automatically performed and the wizard indicates that the process is successful.

Step 3: To check the firmware is well installed, go to **Maintenance > Printer commands prompting** and send a **Rfv** command to the printer. The answer must be the firmware version that you just installed.



Only the upgrade is possible. It is not possible to downgrade the firmware version.

7.3.4.8. Administration





7.3.4.8.1. Standby Settings

Use this window to manage the standby and sleep modes.

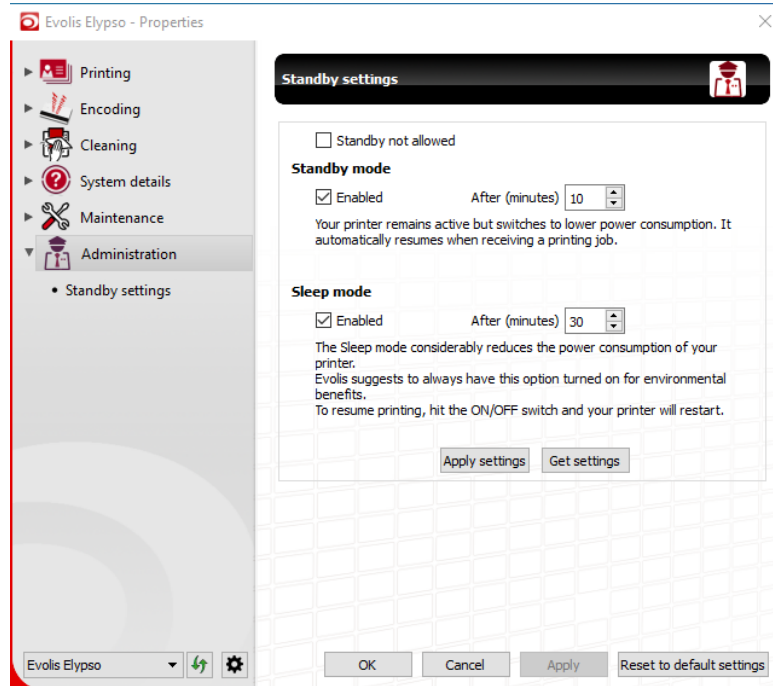
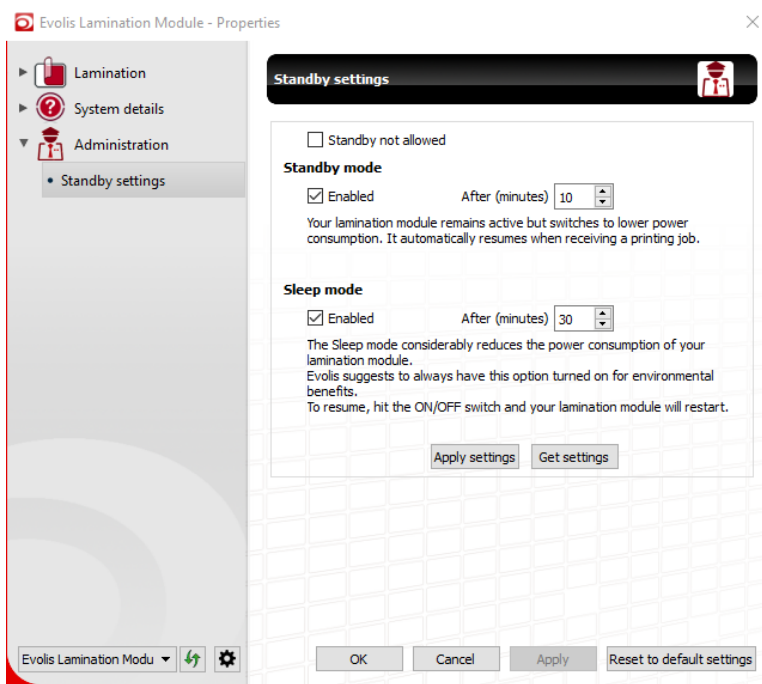
By default, the **Standby** mode is set at 10 minutes and the Sleep mode is set at 30 minutes.

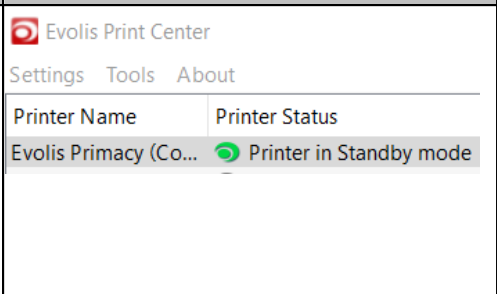
If you change the settings, do not forget to click on **Apply Settings** to confirm the change.

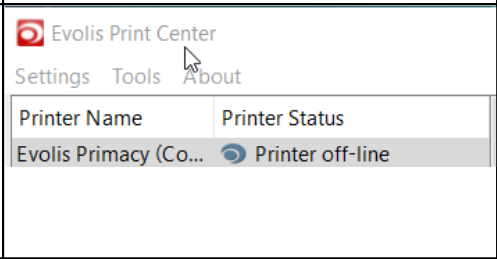

| Mode | Print Center status | Start button is switched off | How to get out of the mode | | | | |
|---|---|------------------------------|----------------------------|-----------------------|-------------------------|--|---|
| <p>Standby Mode (the printer or lamination module uses lower consumption)</p> |  <p>Evolis Print Center Settings Tools About</p> <table border="1"> <tr> <th>Printer Name</th> <th>Printer Status</th> </tr> <tr> <td>Evolis Primacy (Co...</td> <td>Printer in Standby mode</td> </tr> </table> | Printer Name | Printer Status | Evolis Primacy (Co... | Printer in Standby mode |  | <p>On the printer : briefly press the start button or start a printing job</p> <p>On the lamination module: please refer to section Standby Mode and Sleep Mode</p> |
| Printer Name | Printer Status | | | | | | |
| Evolis Primacy (Co... | Printer in Standby mode | | | | | | |
| <p>Sleep Mode (the printer or lamination module uses even lower consumption)</p> |  <p>Evolis Print Center Settings Tools About</p> <table border="1"> <tr> <th>Printer Name</th> <th>Printer Status</th> </tr> <tr> <td>Evolis Primacy (Co...</td> <td>Printer off-line</td> </tr> </table> | Printer Name | Printer Status | Evolis Primacy (Co... | Printer off-line |  | <p>On the printer : briefly press the start button</p> <p>On the lamination module: please refer to section Standby Mode and Sleep Mode</p> |
| Printer Name | Printer Status | | | | | | |
| Evolis Primacy (Co... | Printer off-line | | | | | | |

7.3.4.8.2. Network Settings (Web Interface)

NOTE This feature is only available in **Standard** and **Supervision** modes.

The button displayed provides access to the Web interface of the current printer.

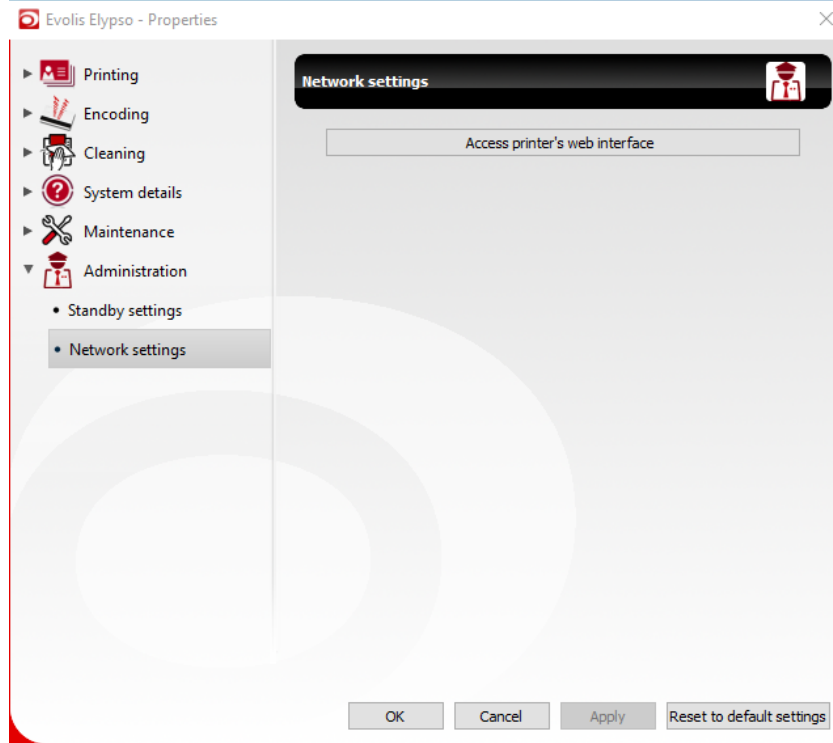

This webpage enables to configure the network settings. Please go to the following sections:

- [Checking Connection With the Printer](#)⁴¹
- [Performing the Detection of the Printer in Wi-Fi](#)⁴⁴

It also enables to configure standby settings:

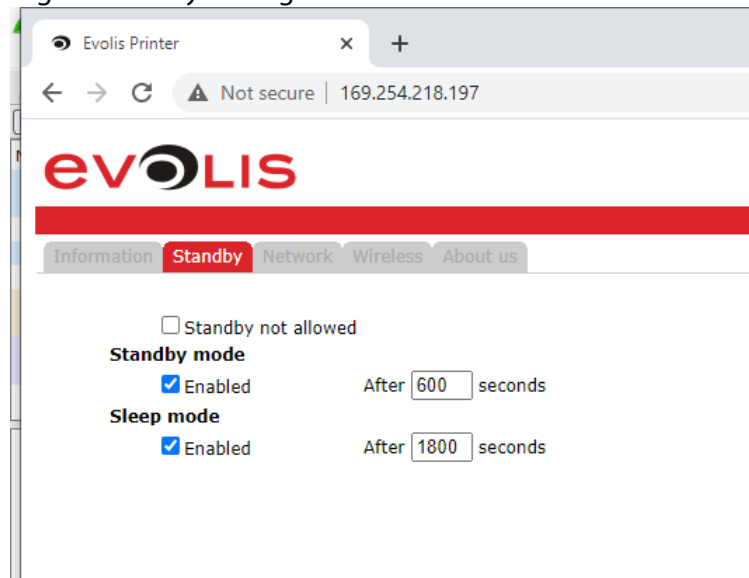

8. Troubleshooting

This section aims at listing the steps needed to solve specific issues.

For some issues that are more complex to solve, you will be asked to contact your Evolis reseller or the [Support](#) team. In this case, it would be necessary that you provide the .dat file mentioned in section [Printer Driver Settings](#)¹⁴⁶ (Step 1).

8.1 Connection Issues

• **Printing job is not successful**

1. Check that you have selected the right printer in the Print window of your application.

2. Check the connection with the printer ([Checking Connection With the Printer](#))⁴¹

If it is not successful, check the IP address of the printer is on the same network range as the computer.

• **Ethernet cable is not detected**

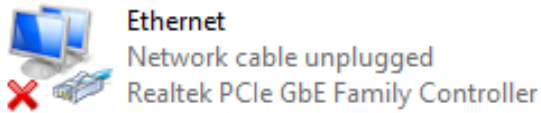
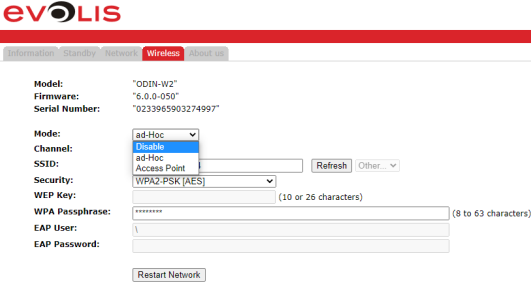
| If... | Perform the following actions |
|---|---|
| <ul style="list-style-type: none"> ▪ Checking Connection With the Printer⁴¹ is not successful ▪ In Control Panel>Network and Internet>Network Connections, the Ethernet card appears as "cable is unplugged" whereas the cable is well connected  <ul style="list-style-type: none"> ▪ The printer Ethernet port has a static orange color (it is not blinking nor green colored) | <ol style="list-style-type: none"> 1. Change the Ethernet cable 2. If using a switch, change the port of the cable 3. Check your computer configuration (the Ethernet card must be enabled and its driver must be up to date) 4. Deactivate the Wi-Fi module <ul style="list-style-type: none"> • enter the following command Pwif;MDE;2 • or do a long push on the printer power on/off button • or select Disable and click on Restart Network from the Web interface  5. Restart the printer |

• **Printer detection from the wizard has failed**

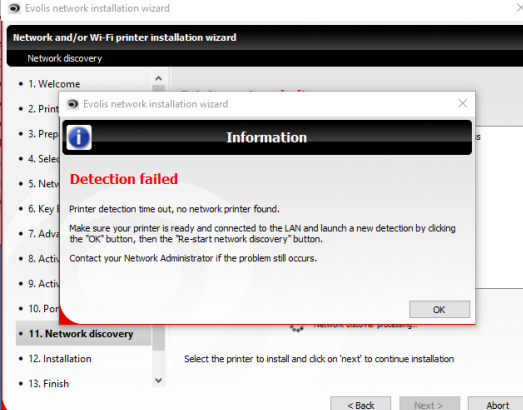
| Type of connection | Issue | Possible Solutions |
|----------------------------------|---|--|
| <p>Ethernet - IP/DHCP</p> | <p>Detection failed in the wizard</p>  | <ul style="list-style-type: none"> - check the firewall and antivirus policy: port 9100 must be allowed, as well as multicast - the address of your computer must also be a IP/DHCP one |
| <p>Wi-Fi</p> | <p>Detection failed in the wizard The Web interface is not displayed</p> | <ul style="list-style-type: none"> - check the firewall and antivirus policy: port 9100 must be allowed, as well as multicast, http/https and broadcast ports - check the IP address of the printer and the computer: they must be in the same network range |

8.2 Printing Issues

Enter topic text here.

8.2.1. Faded Colors

This type of result (faded colors) may be caused by using a wrong power supply.



Please refer to your printer User Guide to check the supply power that is adequate.

8.2.2. Torn Ribbon

Step 1: Proceed to to fix the torn ribbon.

Use tape to put the panels  back together:



Step 2: Solve the issue to avoid another tearing of the ribbon.

Various checkings may solve the issue:

| Type of checking | Steps to follow |
|---|---|
| Check firmware version | From the Maintenance ¹⁴⁴ tab, enter Rfv. If the command returns a wrong answer, proceed to Firmware Update ¹⁴⁸ |
| Check the printer sensors working | From the Maintenance ¹⁴⁴ tab, enter the Sa command. If the command returns a wrong answer, please contact your Evolis reseller or the Support team. |
| Check offsets settings | The ribbon is torn if a hot printhead goes down on the ribbon when there is no card under it. Please contact your Evolis reseller or the Support team. |
| Check temperature values applied in the driver | The temperature may have been pushed to the max for the black panel (when printing a barcode for instance). For other designs, this setting may cause ribbon tearing issue. As a reminder, default value for monochrome resin adjustment parameter is 10. |
| Check the ribbon | A faulty consumable may be the cause of the issue. Replace by a ribbon from a different batch lot number. |
| Check printhead serial number | A printhead replacement or a mistake may have sent a wrong value to the printhead. |

| Type of checking | Steps to follow |
|-------------------------------------|--|
| | In Maintenance > Print Head Replacement ^[147] , check that the answer to the Rkn command matches with the barcode stuck on the printhead. If the answer does not match, send the value displayed on the barcode through the Pkn command or using the wizard. |
| Check card surface / quality | Check the card freshness: a simple test consists in bending the card. With time and/or bad storage conditions, cards become brittle and their surface is not porous anymore. |

8.2.3. Card Design Software with Interfering Options

Some options and features in the software you are using to design your card, may cause interferences with the options selected in the driver settings.

Print Options in Adobe Acrobat Reader (and other Adobe® softwares)

1. Interference with driver configuration when specific settings are set:

- print in grayscale:

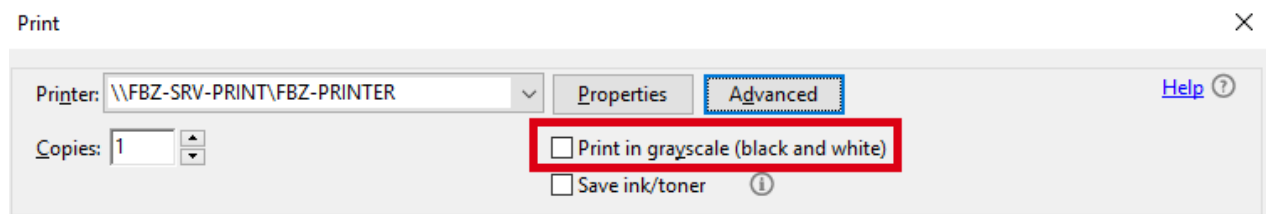

- flip/orientation options:

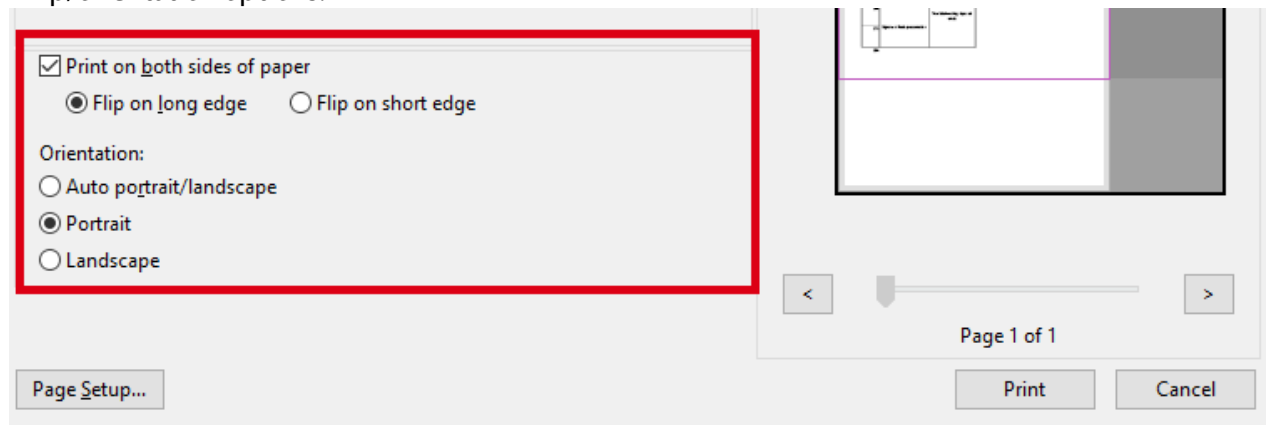

2. Interference with black dots  settings

Print as an image (in **Print > Advanced**) means the file (text and images) is transformed into an image.

No detection of text and images is possible and the whole design is printed in composite colors.

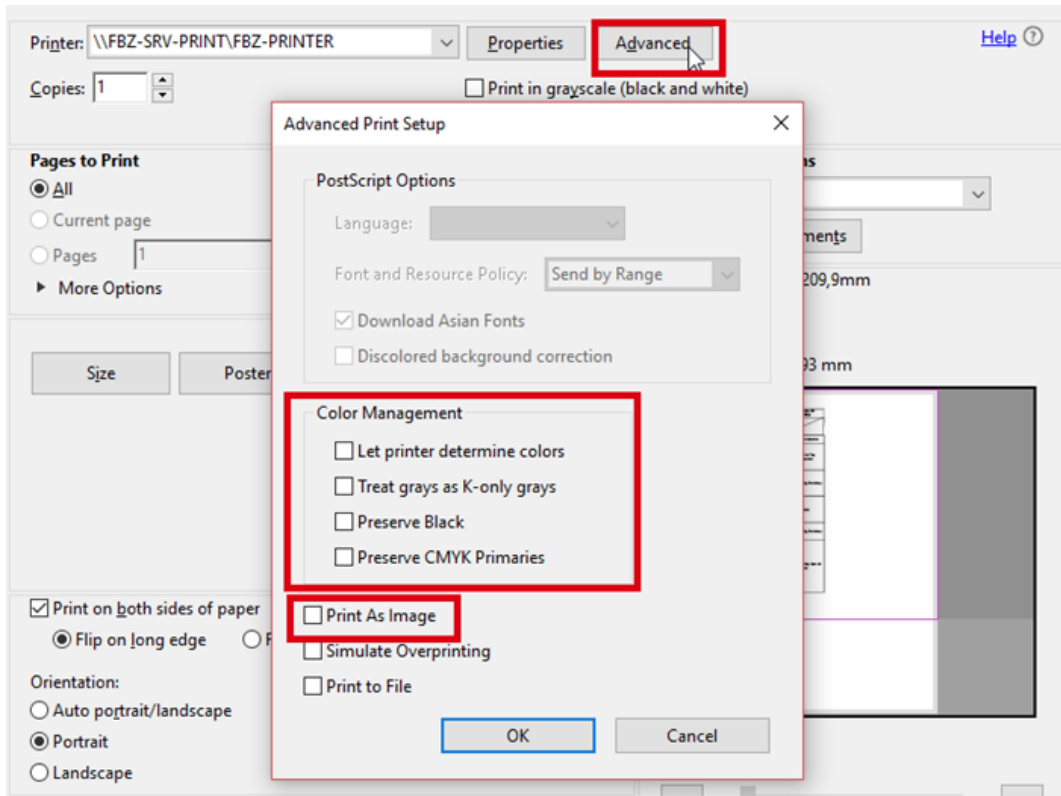

3. Resolution and color management (in **Print>Advanced**)

- In older versions of the software, default resolution is set to 96 dpi  (or 72 dpi) when color printers use up to 600 dpi
- **Color space** has to be the same as Evolis driver (RGB). Evolis driver then translates RGB values into CMYK values

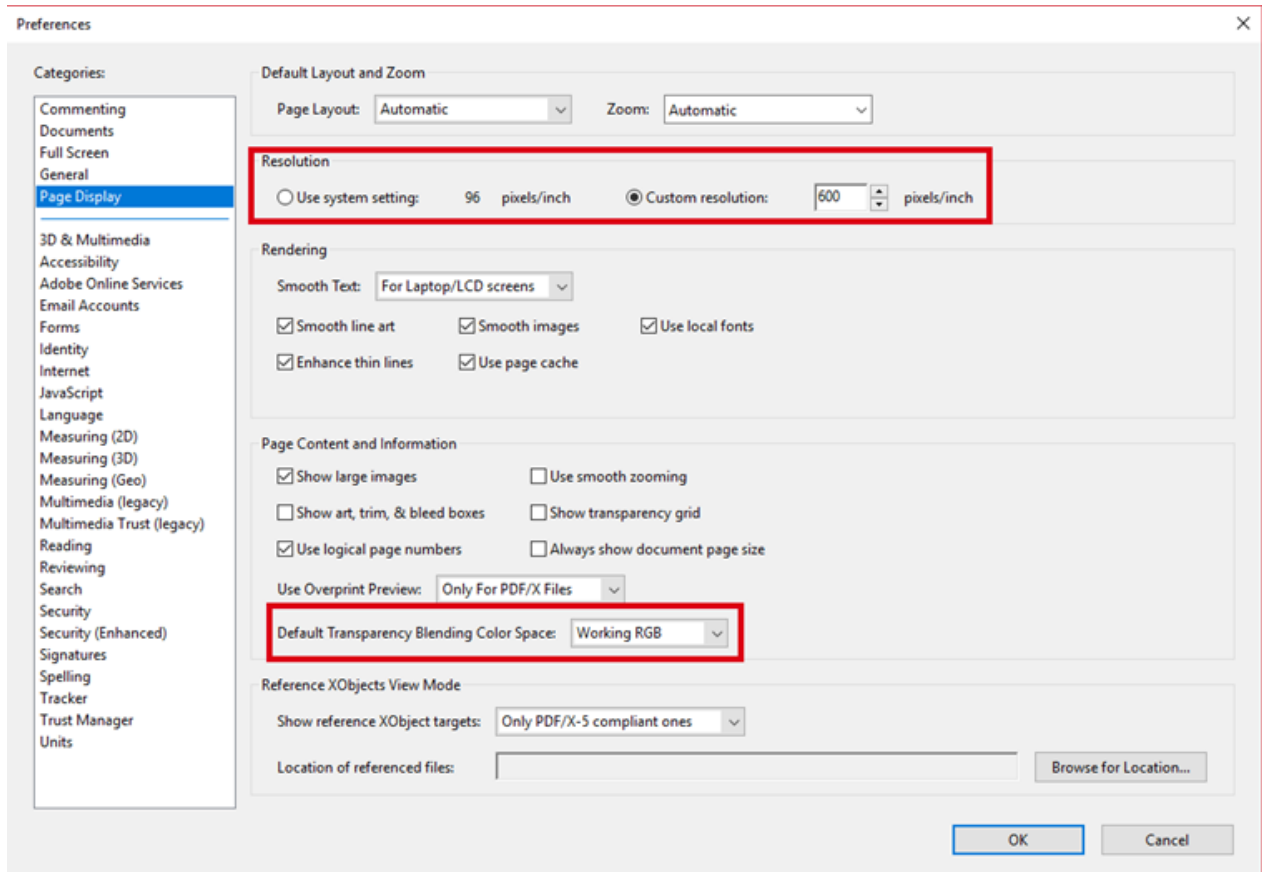

Cardpresso black Management

In case of black background on the card: if the user does not configure any other setting, it is printed in composite black , whereas the color wanted is pure black.

As a workaround: use a rectangle shape, bigger than the card and send the shape to the back so that Cardpresso can consider it as a background.

Then other graphical elements are added above this shape.

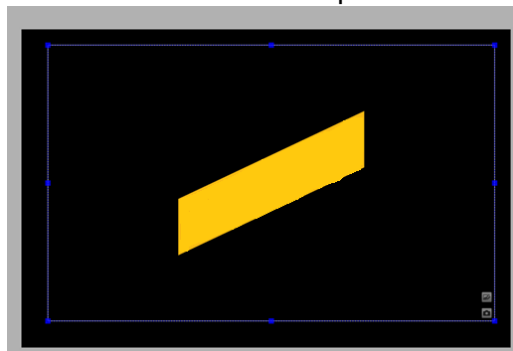

In CardPresso **Print options > Settings > Rendering > Black** can be selected as an option that will enforce the use of the black panel .

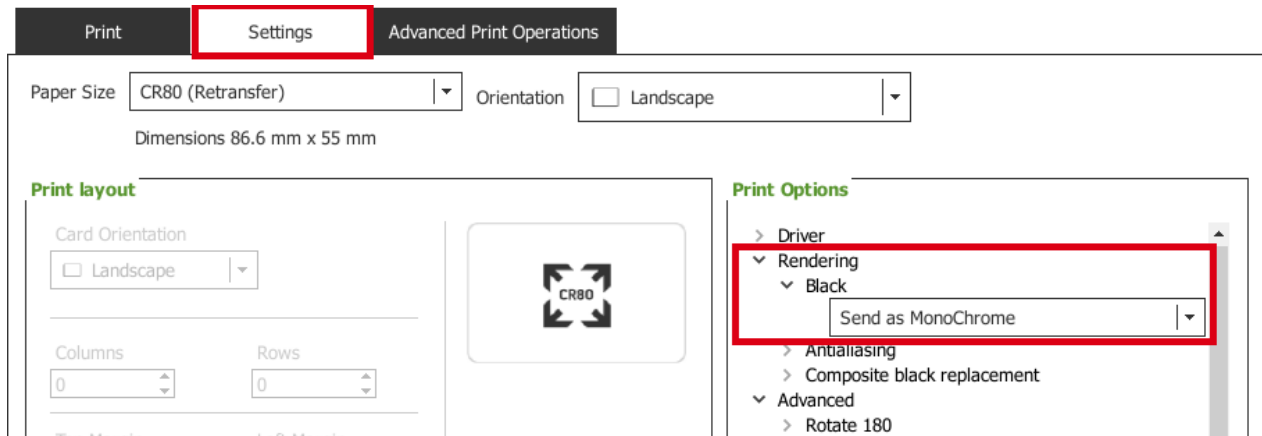

8.2.4. Unreadable Barcode

In specific cases, the surface quality of some cards do not allow a good rendering of the barcode printing, which makes it unreadable by the appropriate scanner.

Example:



Resin adjustment set to 10
Monochrome printing speed set to 10

The barcode was printed using Evolis Printing default settings.

Procedure to improve the printing:

Step 1: Increasing the resin adjustment improves the result.



Resin Adjustment set to 16



Resin Adjustment set to 18

Step 2: If Increasing the resin adjustment does not produce a better print quality, decrease the printing speed by dropping 2 points at first (go to section [Advanced Parameters](#)⁽¹⁰⁴⁾), :



Resin Adjustment Set on 20
+ Slower Printing Speed



A slower printing speed produces a better ink adhesion on the card.

For an even better result, you can use a blackflex ribbon combined with the default settings of the Print Center (resin adjustment and printing speed both set to 10).

8.3 Regular Cleaning

During the cleaning process, you may have the following error message:

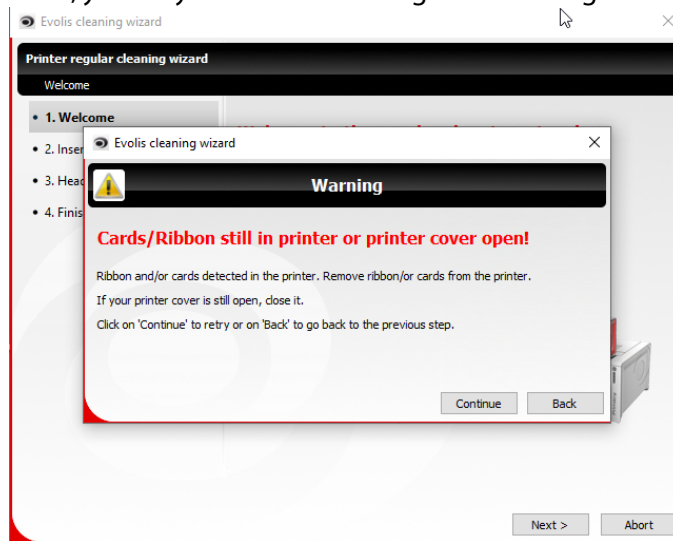

Remove the cards, remove the ribbon or close the printer cover and click on **Continue** to restart the cleaning.

8.4 Print Head Replacement

During the print head replacement action, message **Action failed** is displayed

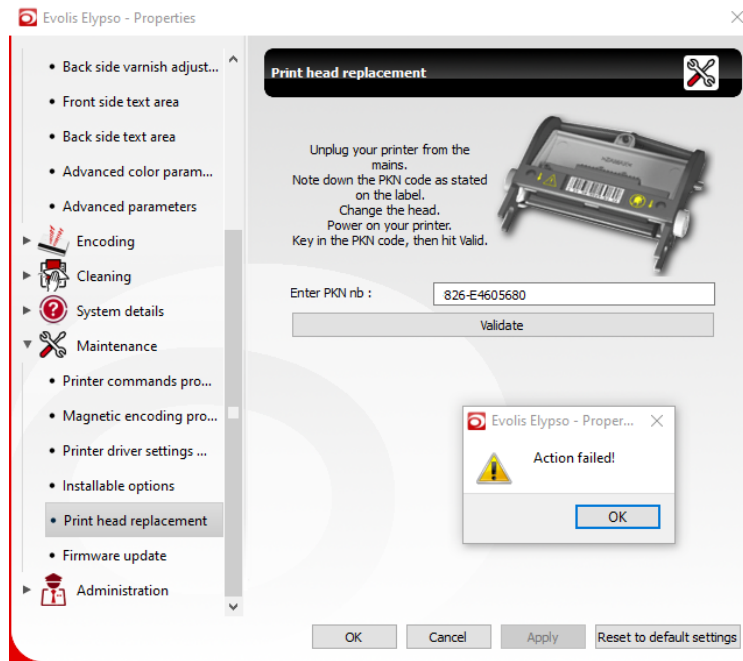





Please check that your printer is fully switched on.
 If not, wait for the LED/LCD indicators to be correct and click again on **Validate** to continue the replacement head process.

8.5 Lamination Troubleshooting

There are two types of issues:

1. Bad rendering of the laminated card

| Lamination Issue | Steps to follow |
|--|---|
|  <p data-bbox="209 1659 616 1727">Marks on the surface Dust under the patch/varnish</p> | <p data-bbox="639 1352 1321 1525">Make sure the cards used are of suitable quality and compatibility Clean the lamination module(s) and the printer. Refer to sections Performing the Cleaning Task¹¹⁷ and Cleaning¹³⁷.</p> |
|  | <p data-bbox="639 1765 1142 1832">Center the lamination patch (offset X) Refer to section Lamination Settings¹⁰⁸.</p> |

| Lamination Issue | Steps to follow |
|---|---|
| <p>Patch position is not adequate</p> | |
|  <p>The lamination patch/varnish has not been correctly applied</p> | <p>Make sure that cards used are of suitable quality and compatibility Check the card type/temperature/speed Refer to section Lamination Settings^[108]</p> |
|  <p>Flaking of the holographic varnish</p> | <p>Replace the film Update the firmware Check the card type/temperature/speed in the Lamination Settings^[108]</p> |
|  <p>Bending of the card</p> | <p>Check the card type/temperature/speed in the Lamination Settings^[108] Use the leveler (refer to the Primacy Lamination User Guide for more details)</p> |

2. Communication errors

- Check the lamination module was plugged in before the printer
- Check that both firmwares for the printer and the lamination module are up to date
- Contact your Evolis reseller or the [Support](#) team if the communication errors persist

www.evolis.com